



Maxi Icarus

SKILL LEVEL 2 – Recommended for Intermediate Rocketeers.

BEFORE YOU START

Read all instructions before beginning work on your model. Make sure you have all parts and materials. When you are thoroughly familiar with the assembly procedure, begin construction. Check off each step as you complete it. In each step, test-fit the parts together before applying any glue. If some part doesn't fit properly, sand lightly or build up as needed for precision assembly.

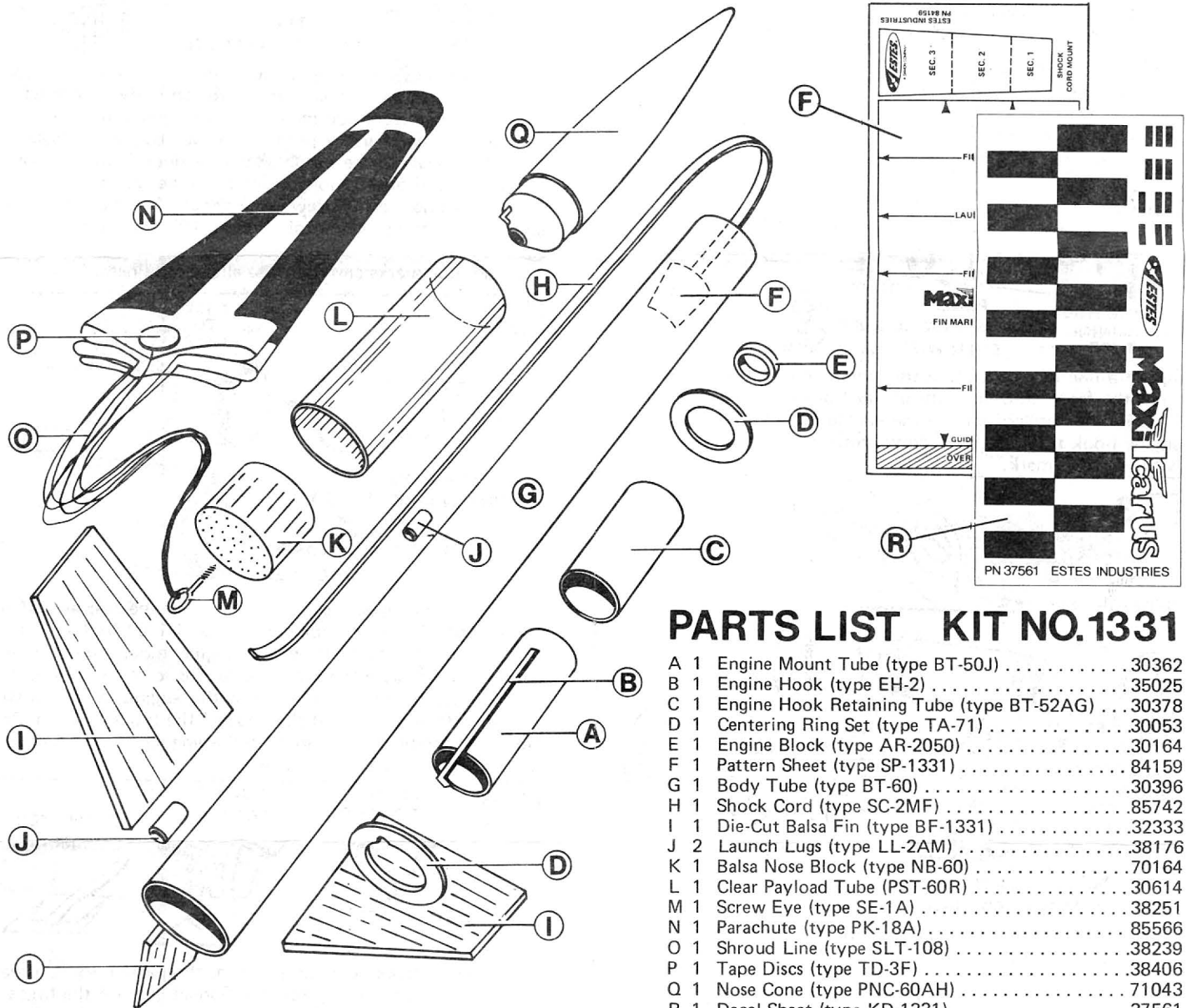

RECOMMENDED ENGINE:
D12-5

PARTS LIST KIT NO.1331

A	1	Engine Mount Tube (type BT-50J)	30362
B	1	Engine Hook (type EH-2)	35025
C	1	Engine Hook Retaining Tube (type BT-52AG) ...	30378
D	1	Centering Ring Set (type TA-71)	30053
E	1	Engine Block (type AR-2050)	30164
F	1	Pattern Sheet (type SP-1331)	84159
G	1	Body Tube (type BT-60)	30396
H	1	Shock Cord (type SC-2MF)	85742
I	1	Die-Cut Balsa Fin (type BF-1331)	32333
J	2	Launch Lugs (type LL-2AM)	38176
K	1	Balsa Nose Block (type NB-60)	70164
L	1	Clear Payload Tube (PST-60R)	30614
M	1	Screw Eye (type SE-1A)	38251
N	1	Parachute (type PK-18A)	85566
O	1	Shroud Line (type SLT-108)	38239
P	1	Tape Discs (type TD-3F)	38406
Q	1	Nose Cone (type PNC-60AH)	71043
R	1	Decal Sheet (type KD-1331)	37561

TOOLS AND MATERIALS

Locate the parts and materials shown in the Parts View and lay them out on the table in front of you. In addition to the parts included in the kit you will also need:

White glue (Titebond, Elmer's or similar)

Plastic model cement, tube type (Use cement made for styrene plastic models.)

A ruler, pencil, small paint brush, scissors, fine- and extra fine sandpaper, sanding sealer.

Gloss white and gloss black paint (Spray paint is recommended.)



A DAMON COMPANY

ESTES INDUSTRIES
PENROSE, CO 81240 USA

ASSEMBLY INSTRUCTIONS

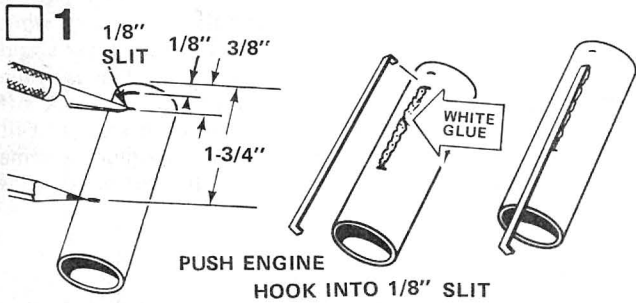

Mark the engine mount tube (part A) 1/8", 3/8", and 1-3/4" from one end. Cut a 1/8" long slit in the tube at the 3/8" mark. Apply a line of glue between the slit and the 1-3/4" mark. Push one end of the engine hook (part B) into the slit as shown. Press the main part of the hook into the glue.

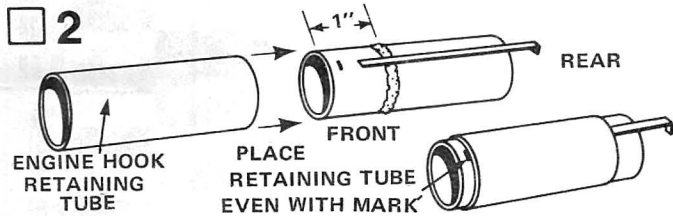

Apply a line of glue around the engine mount tube about 1" from the front end. Slide the engine hook retaining tube (part C) over the forward end of the engine mount tube. Push the engine hook retaining tube down until its forward end is even with the 1/8" mark.

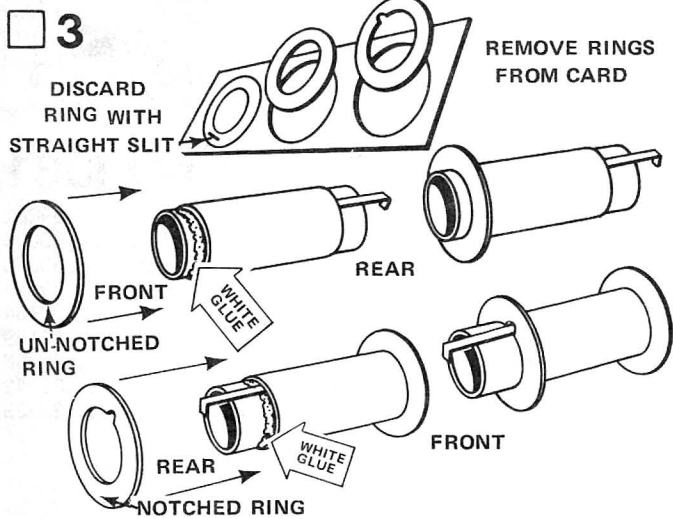

Remove the three centering rings from the die-cut card (part D). Discard the ring with the straight slit. Apply a line of glue around the outside of the engine mount tube just in front of the engine hook retaining tube. Slide the un-notched centering ring onto the forward end of the engine mount tube and up against the engine retaining tube. Apply another line of glue around the engine mount tube just behind the rear edge of the engine retaining tube. Slide the notched centering ring onto the rear of the engine mount assembly and up against the rear of the engine hook retaining tube.

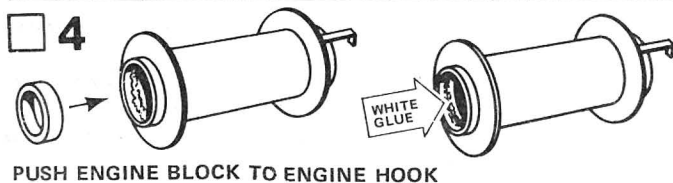

Apply a line of glue all around the inside of the forward end of the engine mount assembly. Push the engine block (part E) into the engine mount tube until it stops at the engine hook. Apply additional glue around the forward edge of the engine block where it touches the inside of the tube.

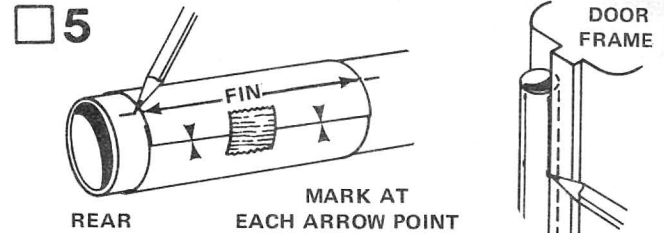

Cut out the body marking guide from the pattern sheet (part F). Wrap it around one end of the rocket body tube (part G). Match the printed guide marks and tape guide in place. Mark the tube at each arrow point. Remove the guide. Place the body tube against the inside edge of a door frame as shown. Draw a line about 3" long from the tube end through each pair of fin line marks. Draw a line about 11" long through the launch lug marks. Mark this line at 10" from rear of body tube. Label the launch lug line. You may use a ruler to connect the tube marks and draw the alignment lines.

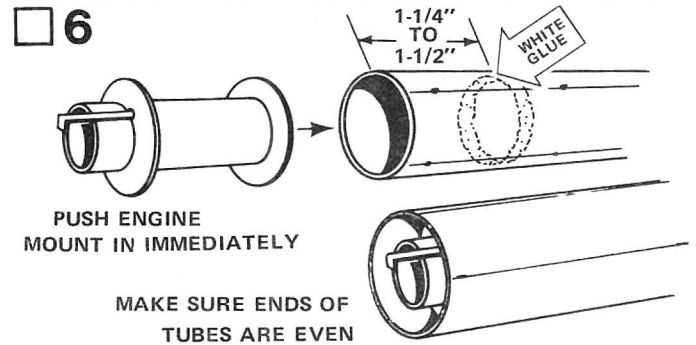

Smear a line of glue around the inside of the rear end of the body tube. The glue should be about 1-1/4" to 1-1/2" from the end of the tube. Push the engine mount unit in right away -- but be sure the mount is turned so the hook will stick out of the end of the tube. Push the engine mount in with one smooth motion until the ends of the tubes are even. Position the engine mount so that the engine hook is centered between two fin alignment lines.

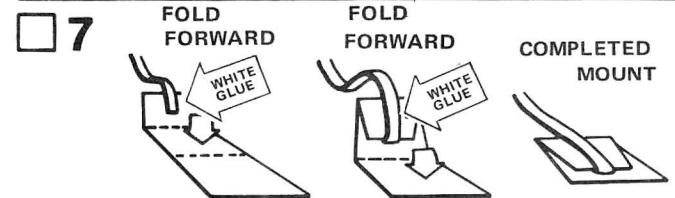

Cut out the shock cord mount from the pattern sheet. Crease it on the dotted lines by folding. Spread glue on the first section (1) and lay the end of the shock cord (part H) into the glue. Fold over and apply glue to the back of the first section and the exposed part of section (2). Lay the shock cord as shown and fold over again. Clamp the unit together with your fingers until the glue sets.

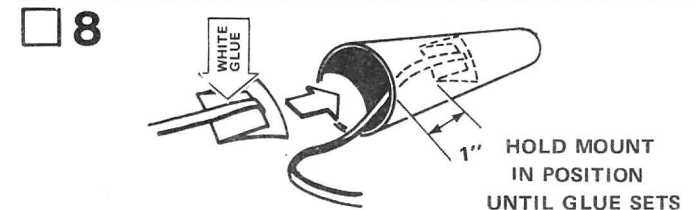

Smear glue over the back side of the shock cord mount as shown. Hold the mount so its wide end enters the tube first, and press it into place in the front of the body tube. Make sure the front of the mount is at least 1" from the tube end to allow for the nose block. Hold the mount in place until the glue sets.

□ 9

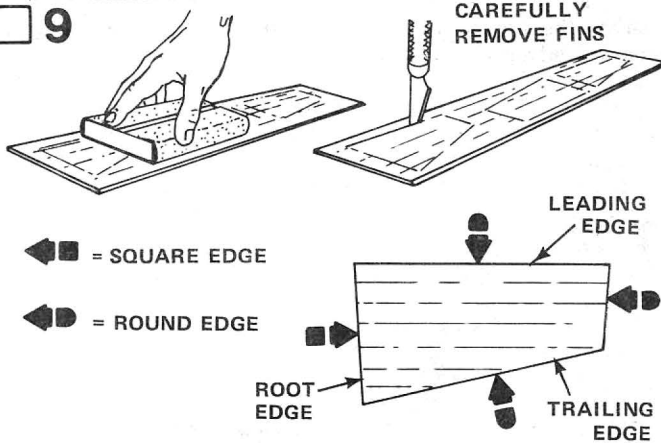

Fine-sand both sides of the balsa sheet (part I). Carefully remove the fins from the sheet using a sharp knife. Sand all fin edges round except the root edge (the edge which glues to the rocket body). The root edge of each fin must be square.

□ 10

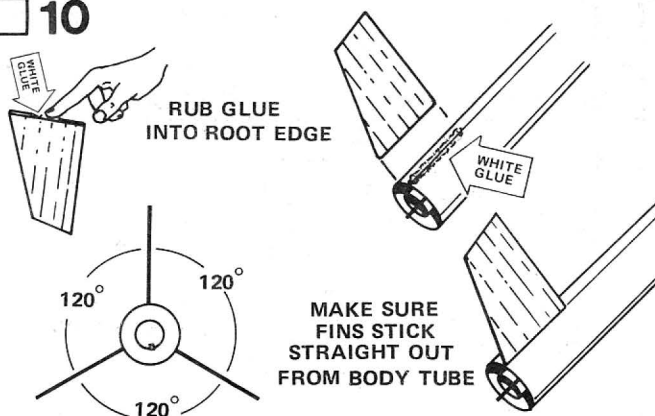

Rub a line of glue into the root edge of each fin and allow glue to dry. Glue the fins to the body on the alignment lines. The rear of each fin should be even with the rear of the body tube. Adjust the fins so they stick straight out from the body. Do not set the rocket on its fins while the glue is drying.

□ 11

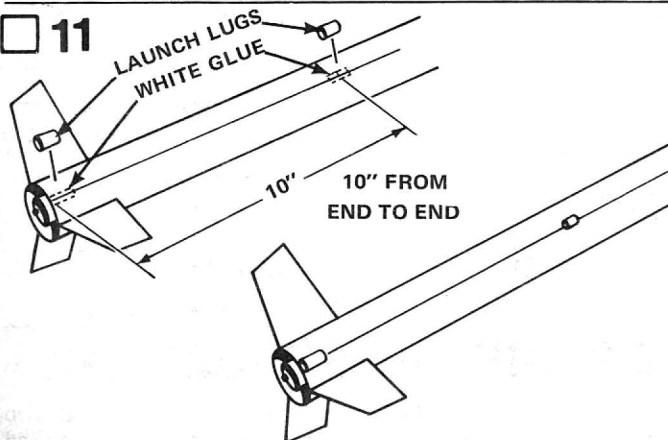

Glue the two launch lugs (part J) to the body tube. Center them on the launch lug line. Glue one launch lug even with the rear of the body tube. Glue the remaining launch lug with its rear 10" from the rear of the body tube.

□ 12

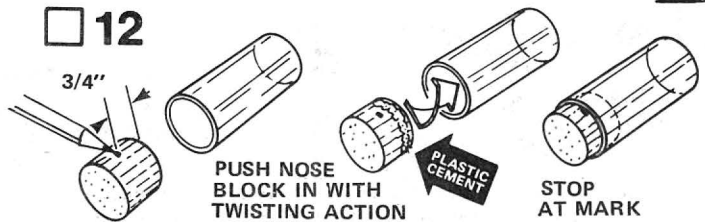

Mark the balsa nose block (part K) 3/4" from one end. Apply a heavy line of tube-type plastic cement completely around the nose block about 1/8" from one end. **DO NOT USE WHITE GLUE.** Push this end of the nose block with a twisting motion into one end of the clear payload section (part L) until the mark is even with the end of the tube. Be sure the nose block is positioned straight in the tube as shown before the cement dries.

□ 13

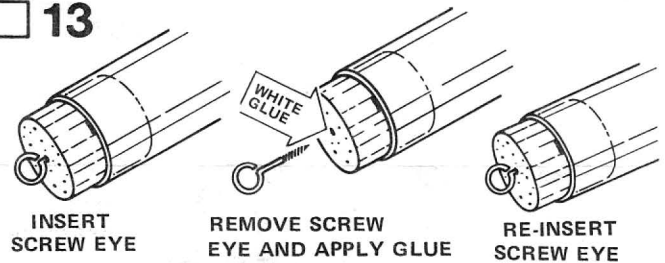

Insert the screw eye (part M) into the rear of the nose block. Remove the screw eye and squirt a small amount of white glue into the hole. Re-insert the screw eye.

□ 14

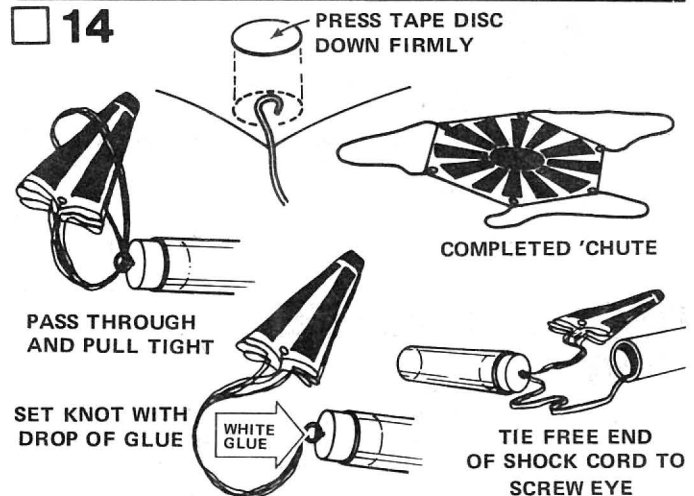

Cut out the parachute (part N) on its edge lines. Cut three 36" lengths of shroud line (part O). Attach line ends to the top of the parachute with tape discs (part P) as shown. Pass the shroud line loops through the screw eye on the nose block. Pass the parachute through the loop ends and pull the lines tight against the screw eye. "Set" the knot with a drop of glue. Tie the free end of the shock cord to the screw eye with a strong double knot or a square knot.

□ 15

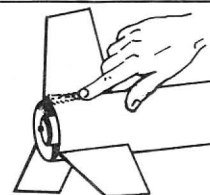

APPLY THIN LINE OF GLUE AND SMOOTH WITH FINGER

When the fin joints have dried, apply glue reinforcements to each joint. Holding the model level, apply a narrow line of glue to both sides of each fin joint. Smooth out the glue with your finger. **IMPORTANT** -- Keep the model level until the glue dries.

16

APPLY
TWO COATS
SANDING
SEALER

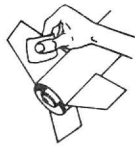

SAND
WITH EXTRA
FINE SAND PAPER

When all glue on the outside of the body is dry, prepare the balsa parts of the model for painting. Apply at least two coats of sanding sealer to all exposed balsa surfaces. Let dry and sand thoroughly with extra-fine sandpaper after each coat. Do this until the tiny holes in the wood are filled and everything looks and feels smooth.

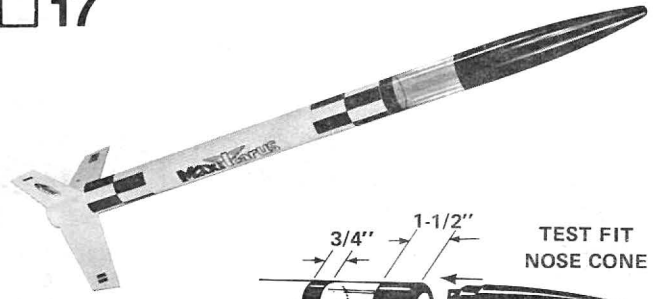
PAINING AND DETAILING**17**

MASK THESE TWO
AREAS WITH MASKING
TAPE FOR PAINTING

TEST FIT
NOSE CONE

Paint the main body tube and fins with two coats of gloss white. Paint two black bands on the clear payload section as shown. The rear band should be 3/4" wide. The forward band should be 1-1/2" wide. Paint the entire nose cone (part Q) black. Test-fit the nose cone in the payload section when the paint is completely dry. It should fit snug but not so tightly that it cannot be removed. If the fit is loose, apply cellophane tape around the base of the nose cone until proper fit is achieved.

DECAL PLACEMENT**18**

When all paint is completely dry, apply decals (part R) in the positions shown. To apply the decals, cut out a decal section, dip it in lukewarm water for 10-20 seconds, and hold it until it starts to uncurl. Slip the decal off the backing sheet and onto the model. Blot excess water away with a damp cloth. When all decals are in place, let the model dry overnight. After drying, apply a coat of clear spray to protect the decals.

LAUNCHING COMPONENTS

To launch your rocket you will need the following items:

- An Estes model rocket launch system
- Parachute recovery wadding (Estes Cat. No. 2274)
- Estes D12-5 model rocket engines

Be sure to follow the HIAA-NAR* Model Rocketry Safety Code when carrying out your model rocketry activities.

*HIAA -- Hobby Industry Association of America
NAR -- National Association of Rocketry

COUNTDOWN CHECKLIST

T-14 Pack 8 or 10 squares of loosely crumpled recovery wadding into the rocket body.

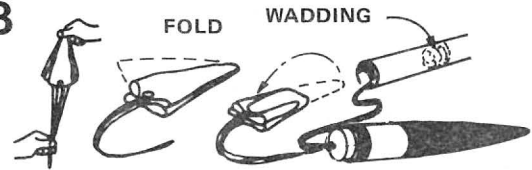
T-13

Gather the parachute as shown, then fold into a triangular shape. Fold again and insert into rocket body.

NOTE: DO NOT pack parachute until you are actually ready to launch. For maximum parachute reliability, lightly dust the 'chute with ordinary talcum powder before each flight, especially in cold weather.

T-12

Pack parachute, shroud lines, and shock cord neatly into rocket body. Slide payload section into place.

Payload section should separate easily from rocket body tube, but should not be extremely loose. If fit is too tight, sand inside of body tube and shoulder of nose block with fine sandpaper. If fit is too loose, add a wrapping of transparent tape or masking tape to the shoulder of the nose block.

T-11

Install an igniter in a D12-5 engine as directed in the engine instructions.

T-10

Insert engine into rocket engine mount. Engine hook must latch securely over end of the engine.

T-9

Disarm the launch panel -- REMOVE SAFETY KEY.

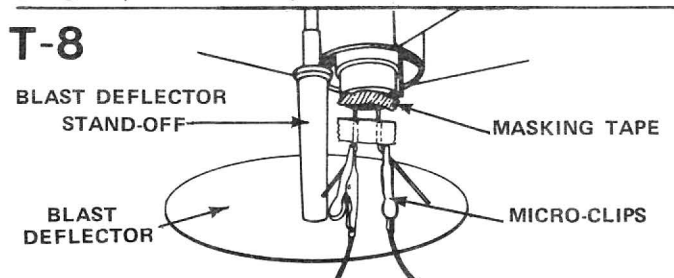
T-8

Slide the launch rod through the launch lugs and place the rocket on the launch pad. Note: The Maxilcarus requires a blast deflector stand-off. If the launch pad you are using does not have one, slide a used engine casing down the launch rod before placing your rocket on the launch rod. Make sure the rocket slides freely on the launch rod. Clean the micro-clips and attach them to the igniter wires. Arrange the clips so they do not touch each other or the metal blast deflector. Attach clips as close to the engine nozzle as possible.

T-7

Clear the launch area, alert recovery crew and trackers. Check for low flying aircraft and unauthorized persons in the recovery area.

T-6

Arm the launch panel -- INSERT SAFETY KEY.

-5-4-3-2-1-LAUNCH!!

Repeat Countdown Checklist for each flight.

MISFIRE PROCEDURE

Occasionally the igniter will heat and burn into two pieces without igniting the engine. This is almost always caused by a failure to install it correctly. REMOVE SAFETY KEY from the launch panel, remove the model, clean the igniter residue from the engine nozzle, and install a new igniter. Repeat the Countdown Checklist.

32
4 8 12 16 20 24 28
**300
DPI**

1 2 3 4 5 6 7 8 9 10 11
8 16 24 32 40 48 56 64 72 80 88 96
TEMPERATURE

No. C303SR

THE L.S. STARETT CO.
ATHOL, MASS., U.S.A.

1/8" Balsa

1 Inch

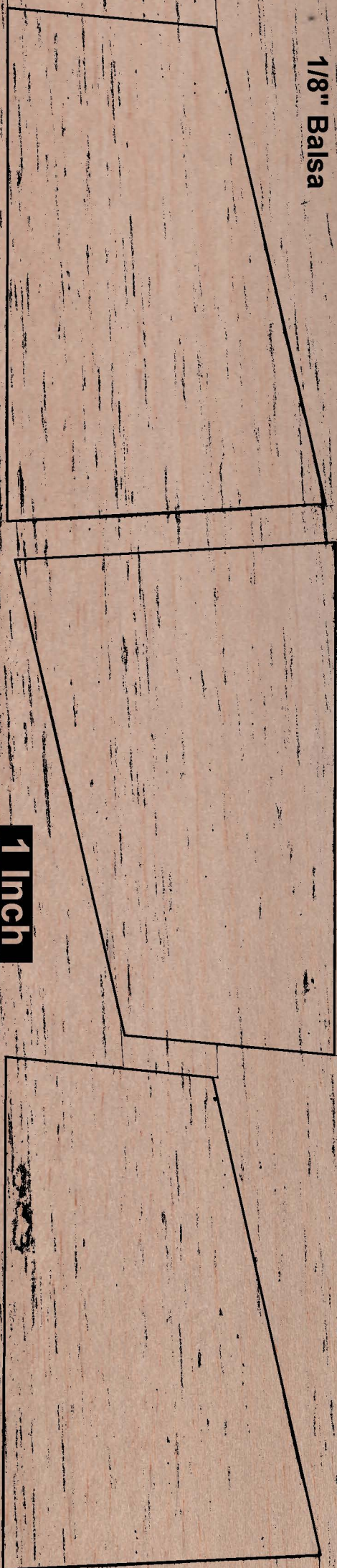

300
DPI



NO. C303SR

THE L.S. STARNETT CO.
ATHOL, MASS., U.S.A.



MAXI-CARTRUS

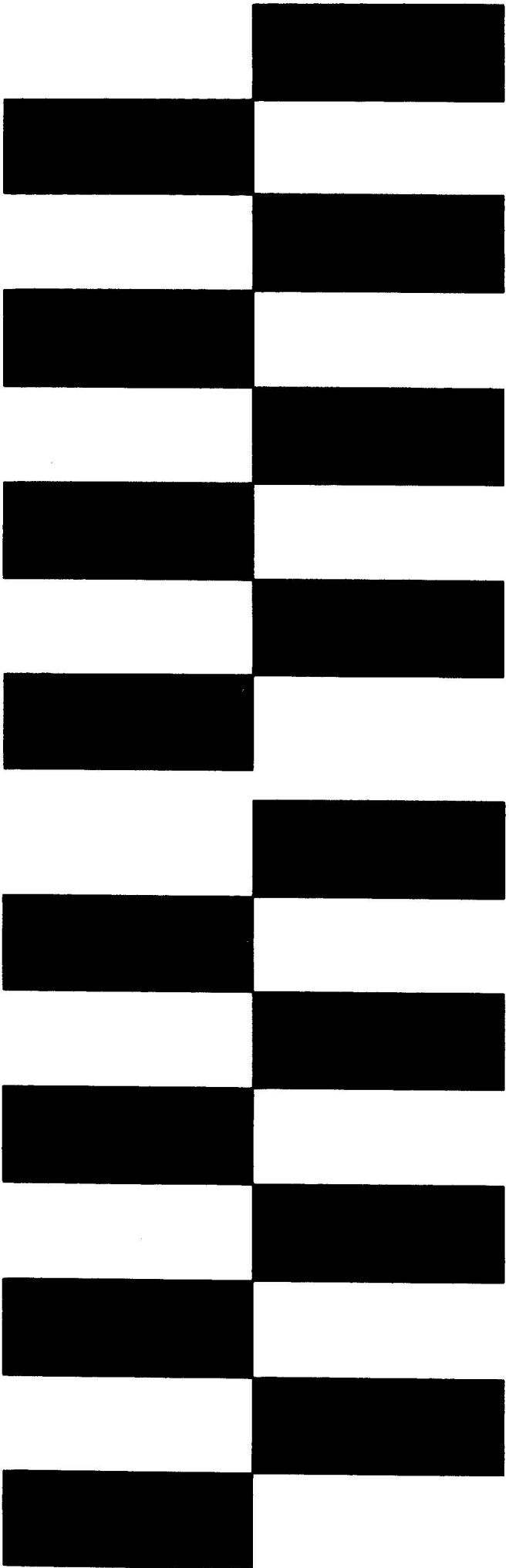

PN 37561 ESTES INDUSTRIES

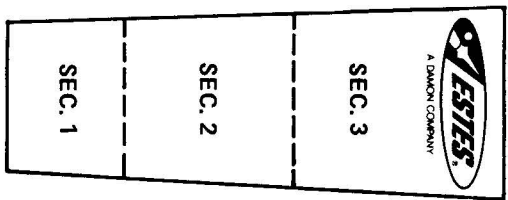
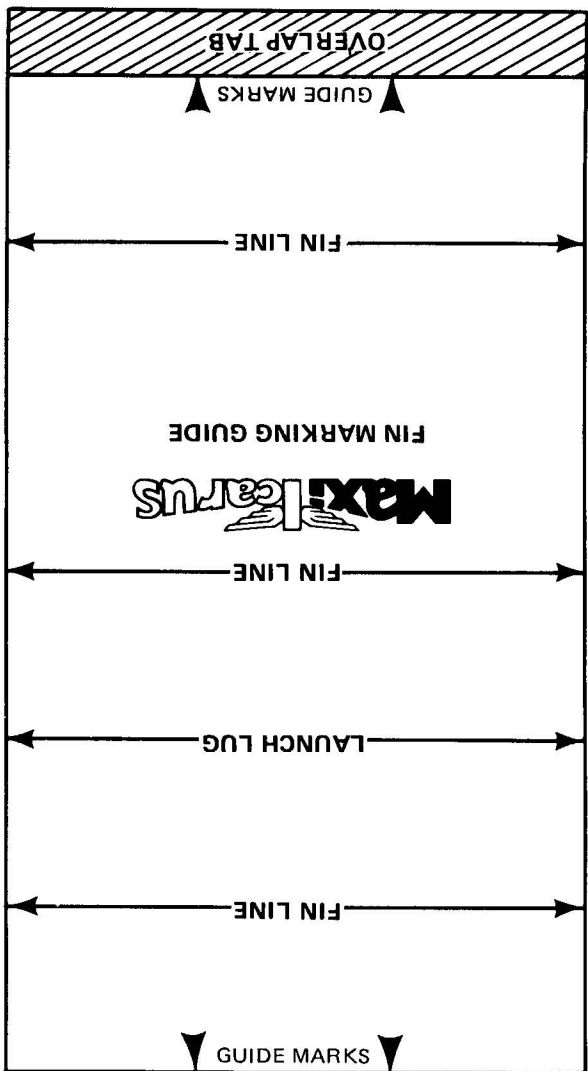

ESTES INDUSTRIES
PN 84159

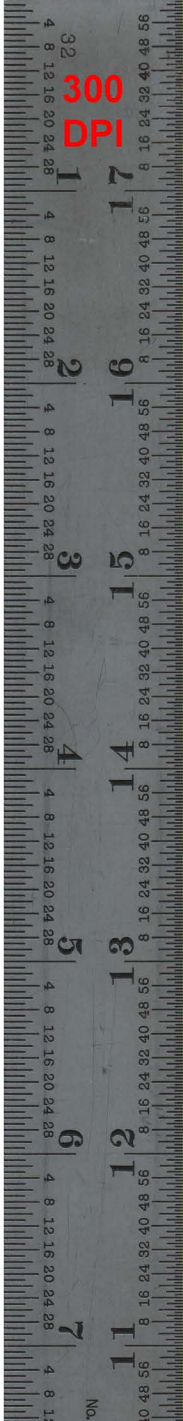

300
DPI

No.

PARTS LIST KIT NO. 1331 - Maxi Icarus

Quantity	Description	Type	Number	Detail1	Detail2	Detail3	Detail4	Comment
1	PAPER BODY TUBE	BT-50J	30362	2.75" long	0.950" ID	0.976" OD	0.013" wall	Glassine
1	ENGINE HOLDER	EH-2	35025	2.8" long	.100" wide	.025" thick		Reg. & D
1	PAPER BODY TUBE	BT-52AG	30378	2.1" long	0.988" ID	1.114" OD	0.063" wall	Glassine
1	PAPER ADAPTER	TA-71	30053	.977" ID	1.594" OD	.05" thick	Set of 2	One ring notched.
1	CENTERING RINGS	AR-2050	30164	0.25" long	0.737" ID	0.949" OD	0.106" wall	Green
1	Pattern Sheet	SP-1331	84159	4" wide	7.5" long	Cardstock		Scan
1	PAPER BODY TUBE	BT-60	30396	18" long	1.595" ID	1.637" OD	0.021" wall	Glassine
1	Shock Cord	SC-2MF	85742	1/4" wide	24" long			Rubber
1	BALSA FIN STOCK	*BFS-40L	3174	3" wide	12" long	1/8" thick		Scan
2	LAUNCH LUG	LL-2AM	38176	5/32" ID	1/8" rod	3/8" long		Mylar
1	BALSA NOSE BLOCK	NB-60	70164	1.5" long	1.595" dia.			BT-60
1	PLASTIC BODY TUBE	PST-60R	30614	5" long	1.595" ID	1.637" OD	0.021" wall	
1	Screw Eye (Large)	SE-1A	38251	1" long				
1	Parachute	PK-18A	85566	18" dia.			Org/Wht	
1	Shroud Line	SLT-108	38239	108"	18" x 6 Shrouds			
1	Tape Disc	TD-3F	38406	1/2" dia.				6x
1	PLASTIC NOSE CONE	PNC-60AH	71043	6.75" long	1.627" dia.	.875" shoulder	BT-60	White Blow molded
1	Decal Sheet	KD-1331	37561	11.5" Long	5" wide	Black	Waterslide	Scan

*BFS-40 is uncut - Die-Cut Balsa Fin (type BF-1331) #32333



Model Rocket

MaxiCarus

FLYING MODEL ROCKET

SKILL LEVEL 2

1-Beginner 2-Intermediate 3-Craftsman
4-Advanced 5-Expert

High super "D" engine powered payload model with large see-thru cargo section. Over 6 cubic inches of up to 80 grams of payload capacity. Includes heavy duty die-cut balsa fins, NASA style roll pattern decal, quick-release engine mount, and big 18" parachute for gentle recovery.



Specifications
Length: 29.34" (75.5 cm)
Diameter: 1.64" (41.6 mm)
Weight: 3.2 oz. (90 g)
18" Parachute Recovery

Recommended Engine
D125

This is a hobby kit requiring assembly. Recommended for ages 14 to adults. Engines, launch system, glue and finishing supplies are not included. Adult supervision is suggested for those under 12 years of age when flying model each time.



ESTES INDUSTRIES
PHOENIX, AZ 85044 USA



1331

Fly Est... Rocket



