



THE BAT

BEFORE YOU START

Read all instructions before beginning construction on your model. Make sure you have all parts and materials. When you are thoroughly familiar with the assembly procedure, begin construction. Check off each step as you complete it. In each step, test-fit the parts together before applying any glue. If some part doesn't fit properly, sand lightly or build up as required for precision assembly.

TOOLS AND MATERIALS

In addition to the parts included in this kit you will need: Scissors, household white glue (Elmer's, Titebond, or similar), pencil, ruler, fine or extra-fine grit sandpaper, sanding sealer, a medium-size modeling paint brush, modeling knife with sharp blade, and gloss black enamel spray paint.

For easy and positive alignment of the fins on your model, we recommend the use of Estes' Fin Alignment Guide, Part. No. 2231.

SKILL LEVEL 1 – Recommended for Beginner Rocketeers.

RECOMMENDED ENGINES:

A8-3 B4-2 B4-4 B6-2 B6-4

B8-5 C6-3 C6-5 C6-7

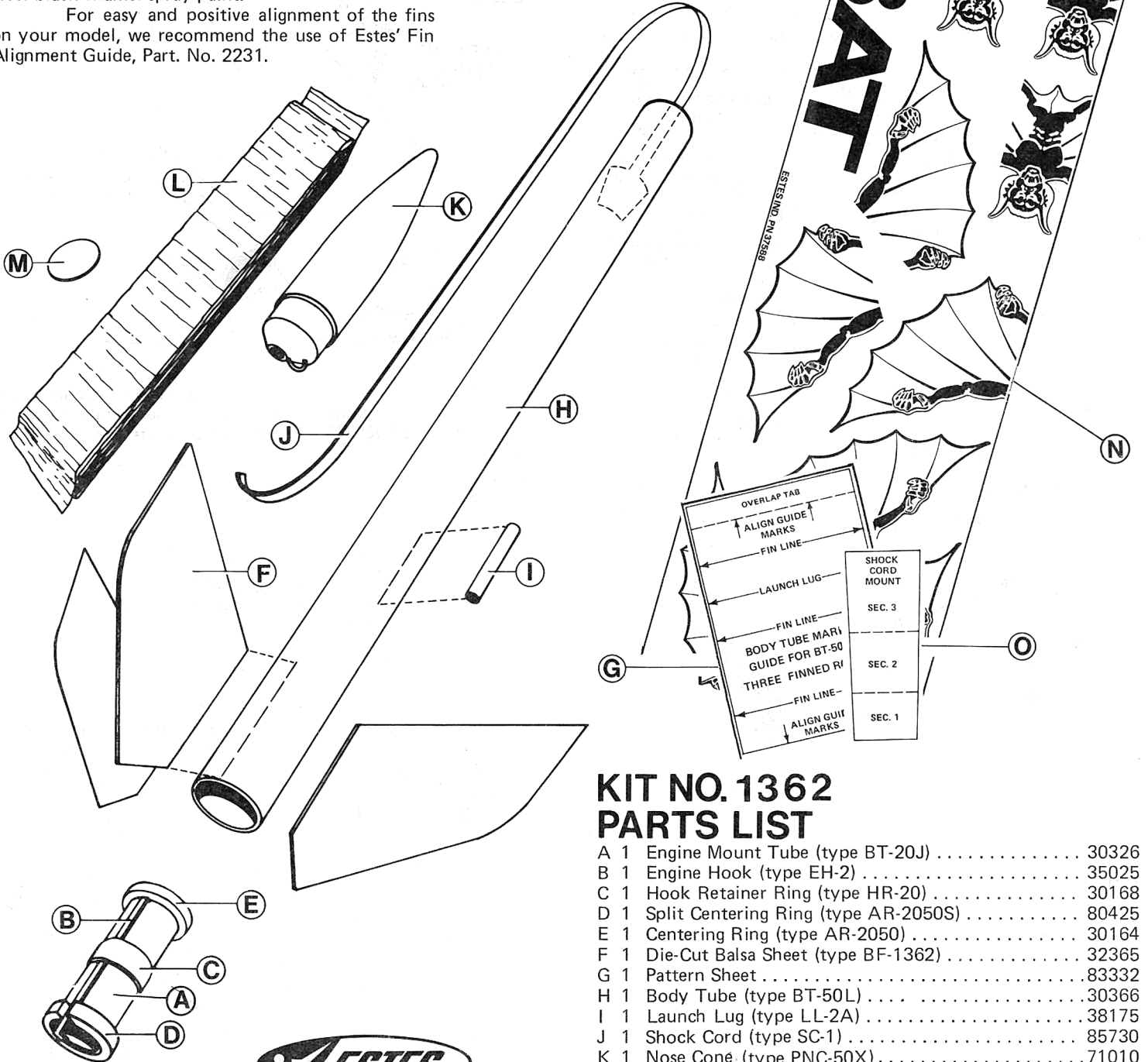

KIT NO. 1362 PARTS LIST

A	1	Engine Mount Tube (type BT-20J)	30326
B	1	Engine Hook (type EH-2)	35025
C	1	Hook Retainer Ring (type HR-20)	30168
D	1	Split Centering Ring (type AR-2050S)	80425
E	1	Centering Ring (type AR-2050)	30164
F	1	Die-Cut Balsa Sheet (type BF-1362)	32365
G	1	Pattern Sheet	83332
H	1	Body Tube (type BT-50L)	30366
I	1	Launch Lug (type LL-2A)	38175
J	1	Shock Cord (type SC-1)	85730
K	1	Nose Cone (type PNC-50X)	71010
L	1	Streamer (type SM-1C)	38273
M	1	Tape Disc (type TD-1)	38401
N	1	Decal Sheet (type KD-1362)	37588
O	1	Shock Cord Mount (type SCM-50)	84444



A DAMON COMPANY

ESTES INDUSTRIES
PENROSE, CO 81240 USA

ASSEMBLY INSTRUCTIONS

1

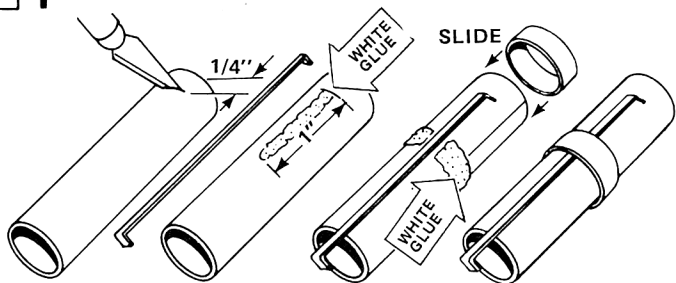

Cut a 1/8" slit in the engine mount tube (part A), 1/4" from one end as shown. Apply a 1" long line of glue to the tube. Push one end of the engine hook (part B) into the slit and press the main part of the hook into the glue. Apply a line of glue around the middle of the tube and slide the hook retainer ring (part C) over tube and hook, onto the glue.

2

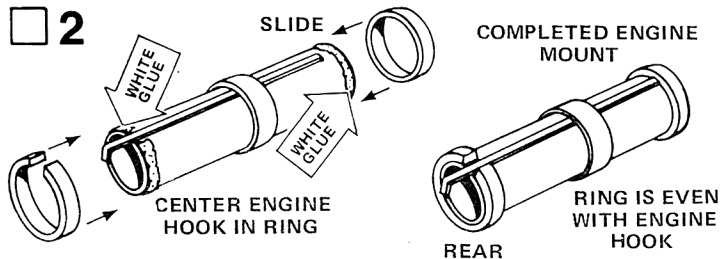

Glue the split centering ring (part D) to the engine mount tube so the engine hook is centered in slot in ring and even with rear of tube. Avoid getting glue into the slot. Glue the other ring (part E) to the front of the engine tube against the end of the hook as shown.

3

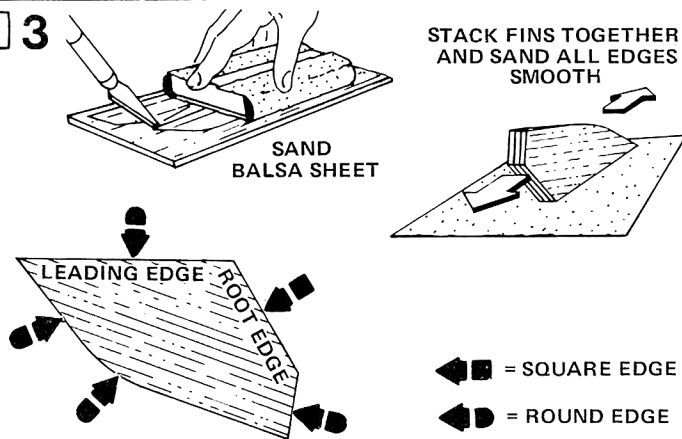

Fine-sand the balsa die-cut sheet (part F). Free the edges with a sharp knife then carefully remove the die-cut fins from the sheet. Sand the leading and trailing edges of the fins round. Leave edge designated root edge square.

4

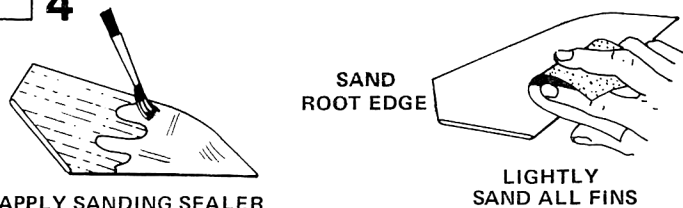

Apply a coat of sanding sealer to each fin. Apply sealer to all edges except the root edge. When sealer is dry, lightly sand all the sealed surfaces. Repeat sealing and sanding process until balsa grain no longer shows. Re-sand root edge, lightly, to remove any sealer.

5

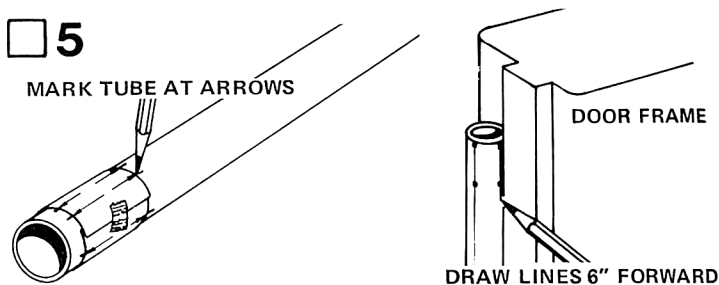

Cut out the tube marking guide from the pattern sheet (part G) and wrap it around the body tube (part H). Mark the body tube at each of the arrow points. Draw straight lines connecting each mark. A door frame inside edge can be used as a guide as shown. Extend the lines about 6" forward from the rear of the tube.

6

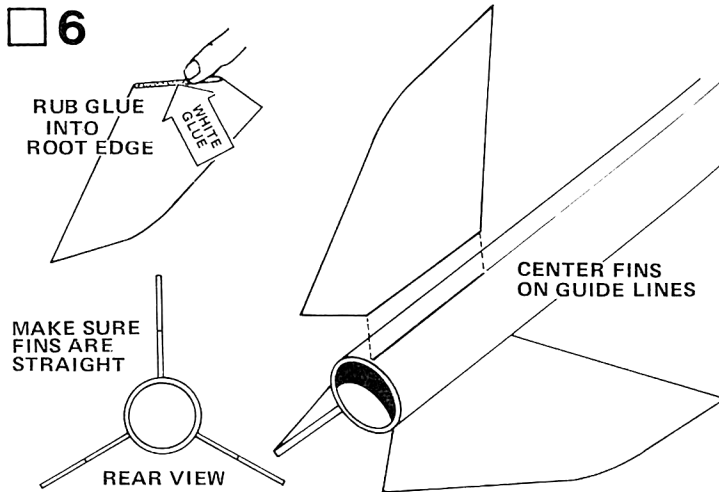

Rub glue into the root edge of each fin and allow to dry. Apply glue to the fins again and position fins on the alignment lines in positions shown. Adjust the fins so they project straight away from the body tube. DO NOT set the rocket on its fins while the glue is wet.

7

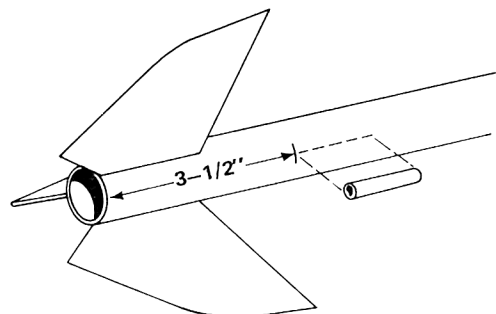

Glue launch lug (part I) to rocket body tube on the launch lug line. The rear of the launch lug should be 3-1/2" from the rear of the rocket body tube. Align the launch lug straight along the body.

8

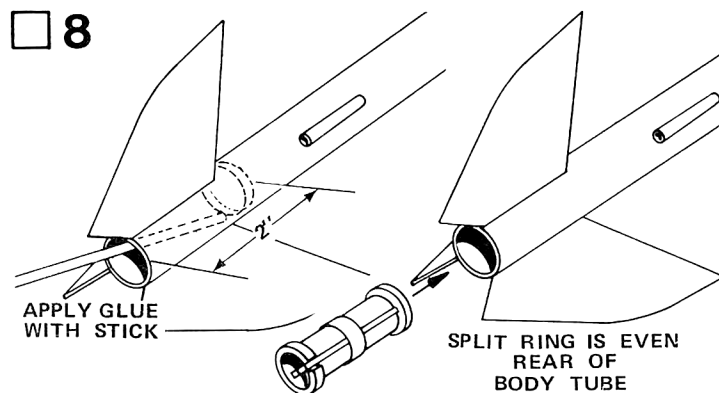

Apply a ring of glue around inside of rear end of body tube about 2" to 2-1/2" from the end of the tube. Apply with a stick or dowel as shown. Immediately insert the engine mount unit, being careful

to position it so the engine hook will stick out of the end of the tube. Push engine mount in with one smooth motion until the split ring on the engine mount is even with the end of the body tube.

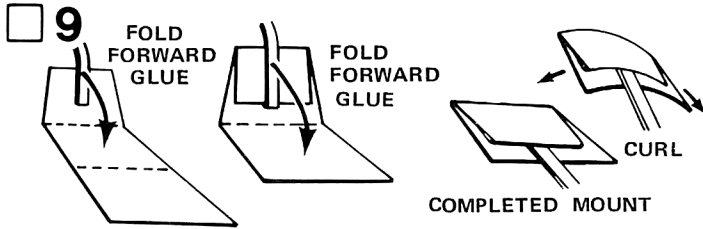

Cut out the shock cord mount (part O). Fold on dotted lines, then unfold and apply glue to Sec. 1. Lay the end of the shock cord (part J) into the glue. Fold over and apply glue to the back of Sec. 1 and the exposed portion of Sec. 2. Fold again to complete mount. Curl the edges of the mount down so it will match the contour of the body tube and hold with your fingers until the glue sets.

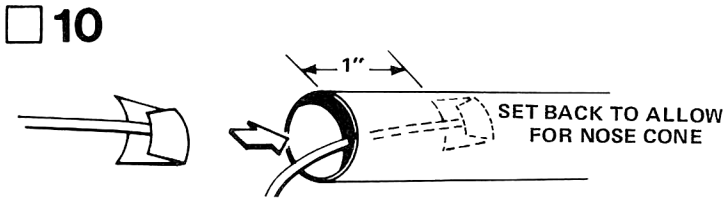

Use a stick or scrap dowel to apply a generous amount of glue inside the body tube 1" from the front edge of the tube to allow clearance at the front of the tube for the nose cone to socket into place. Slide the shock cord mount into the tube and press it into the glue. To insure a good bond use a stick or your finger to smear a film of glue over the mount and surrounding area in the body tube.

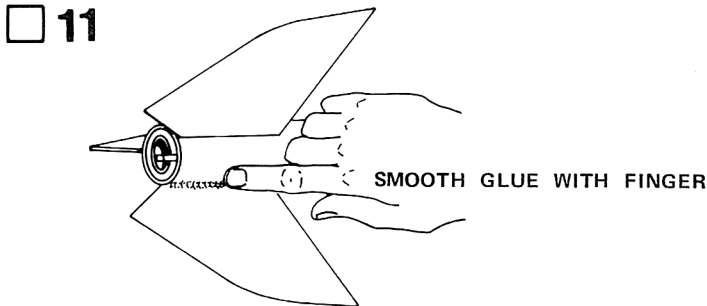

When the glue on the fin joints has dried, apply a glue reinforcement to each fin body tube joint. Holding the model level, apply a line of glue to both sides of each fin joint. Smooth out the glue with your finger. **IMPORTANT** -- Keep the model level until the glue dries.

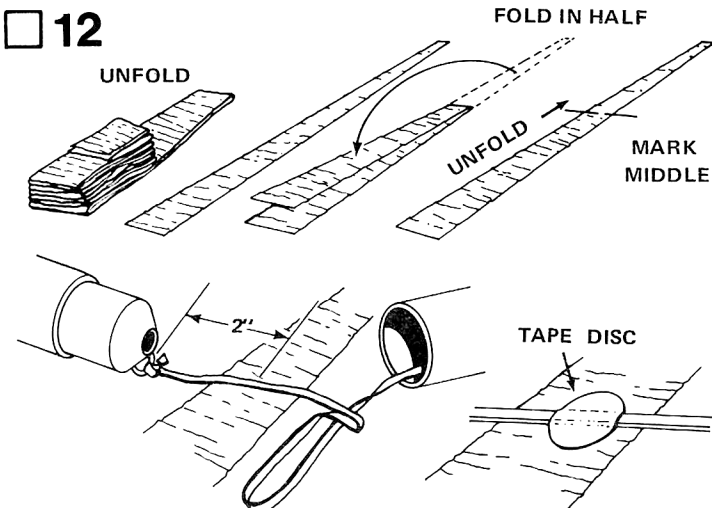

Tie the free end of the shock cord to the nose cone (part K). Unfold the streamer (part L) and fold lengthwise to find its center.

The streamer should be secured to the shock cord about 2" from the nose cone, as shown.

Lay the shock cord across the center of the streamer and secure with the tape disc (part M). Fold the streamer twice lengthwise and roll until it fits into the body tube. Place the remainder of the shock cord and the nose cone into the body tube while completing The Bat.

13

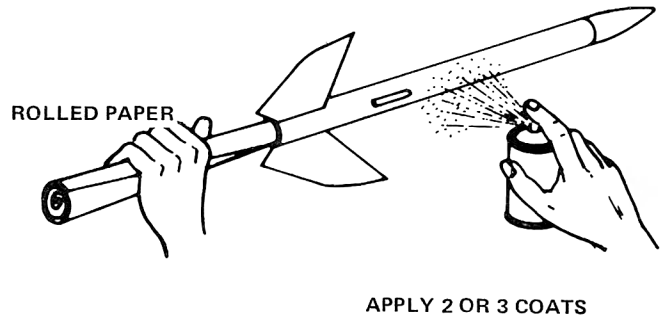

Before painting, clean the rocket with a slightly damp cloth to remove oily fingerprints. The entire rocket is painted gloss black. We recommend Pactra gloss black spray enamel. Do not paint the model with lacquer paint. Lacquer will mar the finish of the plastic nose cone. Spray the model with several light coats of paint to avoid "runs". Allow the rocket to dry for 2 to 4 hours before applying decals.

14

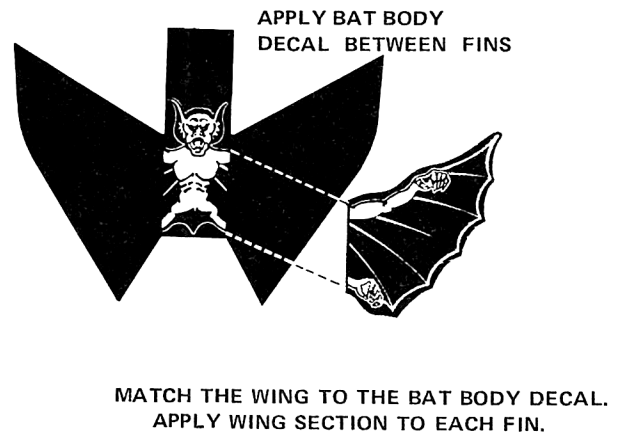

Apply the decals (part N) in the positions shown. (A) Cut only one decal at a time from sheet. (B) Submerge decal in water for 15 to 30 seconds (until decal slides on backing paper). (C) Gently slide decal from backing paper onto model. (D) Move decal into exact position and carefully blot away excess water with a soft cloth. (E) If the decal "sticks" before you have it in position, apply water over the decal with a brush. This will permit the decal to be moved. (F) Smooth out all wrinkles and air bubbles before the decal dries. We recommend that the completed model be sprayed with Testor's "Dull-Cote". This is a clear flat spray paint that kills the decal shine and protects the model's finish.

LAUNCHING COMPONENTS

To launch your rocket you will need the following items:

- An Estes model rocket launch system
- Parachute recovery wadding (Estes Cat. No. 2274)
- Recommended engines: A8-3 (First Flight), B4-2, B4-4, B6-2, B6-4, B8-5, C6-3, C6-5, and C6-7.

Be sure to follow the HIAA-NAR* Model Rocket Safety Code when carrying out your model rocket activities.

*HIAA -- Hobby Industry Association of America
 NAR -- National Association of Rocketry

COUNTDOWN CHECKLIST

T-13 Pack 3 or 4 squares of loosely crumpled recovery wadding into the rocket body.

T-12

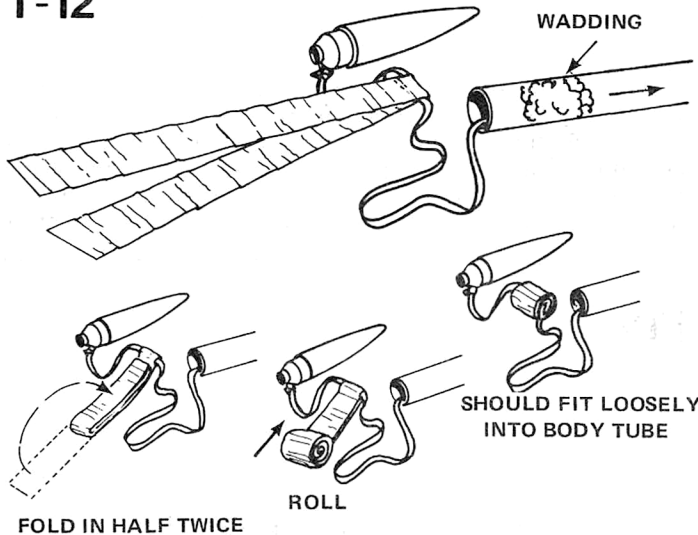

Fold the streamer in half lengthwise. Fold again, then roll until the streamer fits loosely into the rocket body. Pack the shock cord neatly into the rocket body. Slide nose cone into place.

NOTE: Nose cone should separate easily from rocket body tube, but should not be extremely loose. If fit is too tight, sand inside of body tube and shoulder of nose cone with fine sandpaper. If fit is too loose, add a wrapping of transparent tape or masking tape to the shoulder of the nose cone.

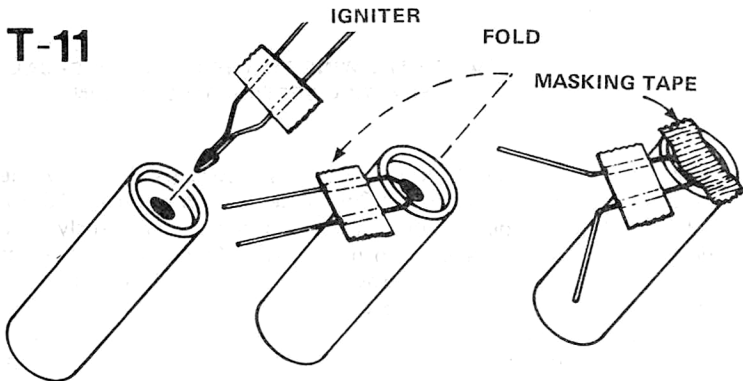

Select an engine and install an igniter as directed in the engine instructions. Use an A8-3 engine for your first flight.

T-10

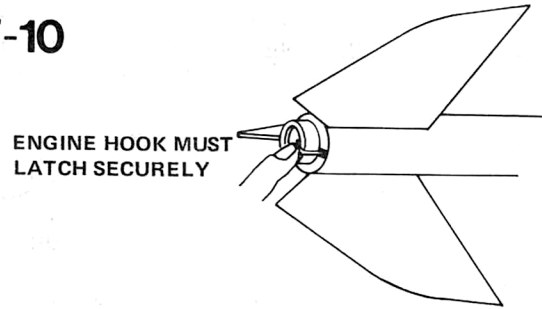

Insert engine into rocket engine mount. Engine hook must latch securely over end of the engine.

T-9 Disarm the launch panel -- REMOVE SAFETY KEY!

T-8

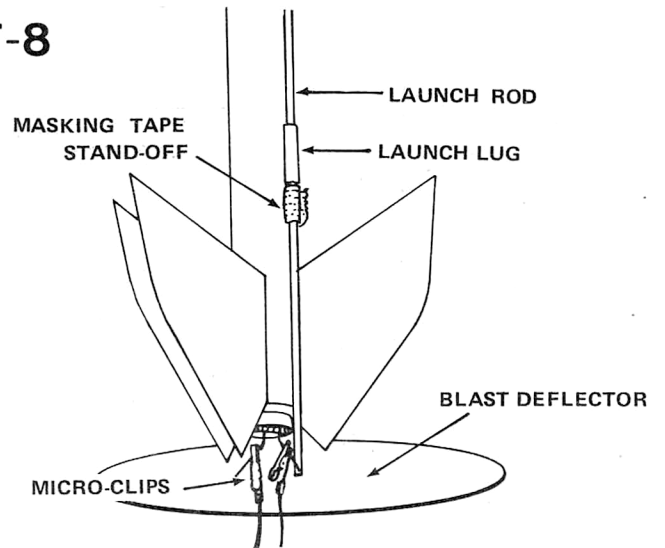

Slide launch rod through rocket launch lug and place rocket on launch pad. Make sure the rocket slides freely on the launch rod. Clean the micro-clips and attach them to the igniter wires. Arrange the clips so they do not touch each other or the metal blast deflector. Attach clips as close to engine as possible.

T-7 Clear the launch area, alert recovery crew and trackers. Check for low flying aircraft and unauthorized persons in the recovery area.

T-6

Arm the launch panel -- INSERT SAFETY KEY!

-5-4-3-2-1-LAUNCH!!

Repeat Countdown Checklist for each flight.

MISFIRE PROCEDURE

Occasionally the igniter will heat and burn into two pieces without igniting the engine. This is almost always caused by a failure to install it correctly. REMOVE SAFETY KEY from launch panel, remove the model, clean the igniter residue from the engine nozzle, and install a new igniter. Repeat the Countdown Checklist.

OVERLAP TAB

ALIGN GUIDE
MARKS

FIN LINE

LAUNCH LUG

FIN LINE

BODY TUBE MARKING
GUIDE FOR BT-50 SIZE
THREE FINNED ROCKETS

FIN LINE

ALIGN GUIDE
MARKS

ESTES INDUSTRIES PN 83332 STANDARD SP-50A





A SUBSIDIARY OF DAMON

SEC. 3

PN 84444

SEC. 2

SEC. 1

**SHOCK CORD
MOUNT
SCM-50**

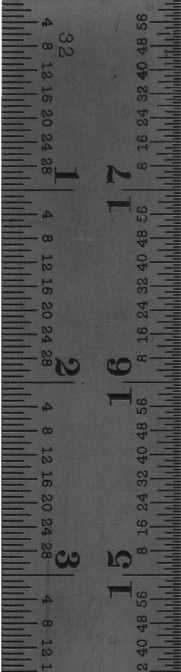

300
DPI

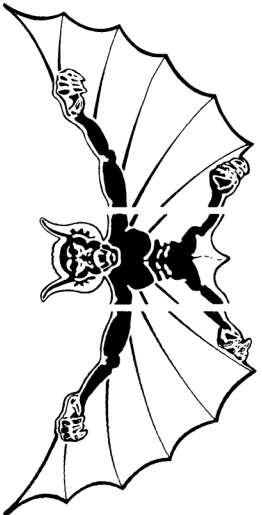
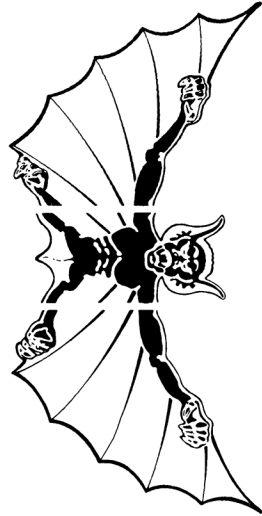
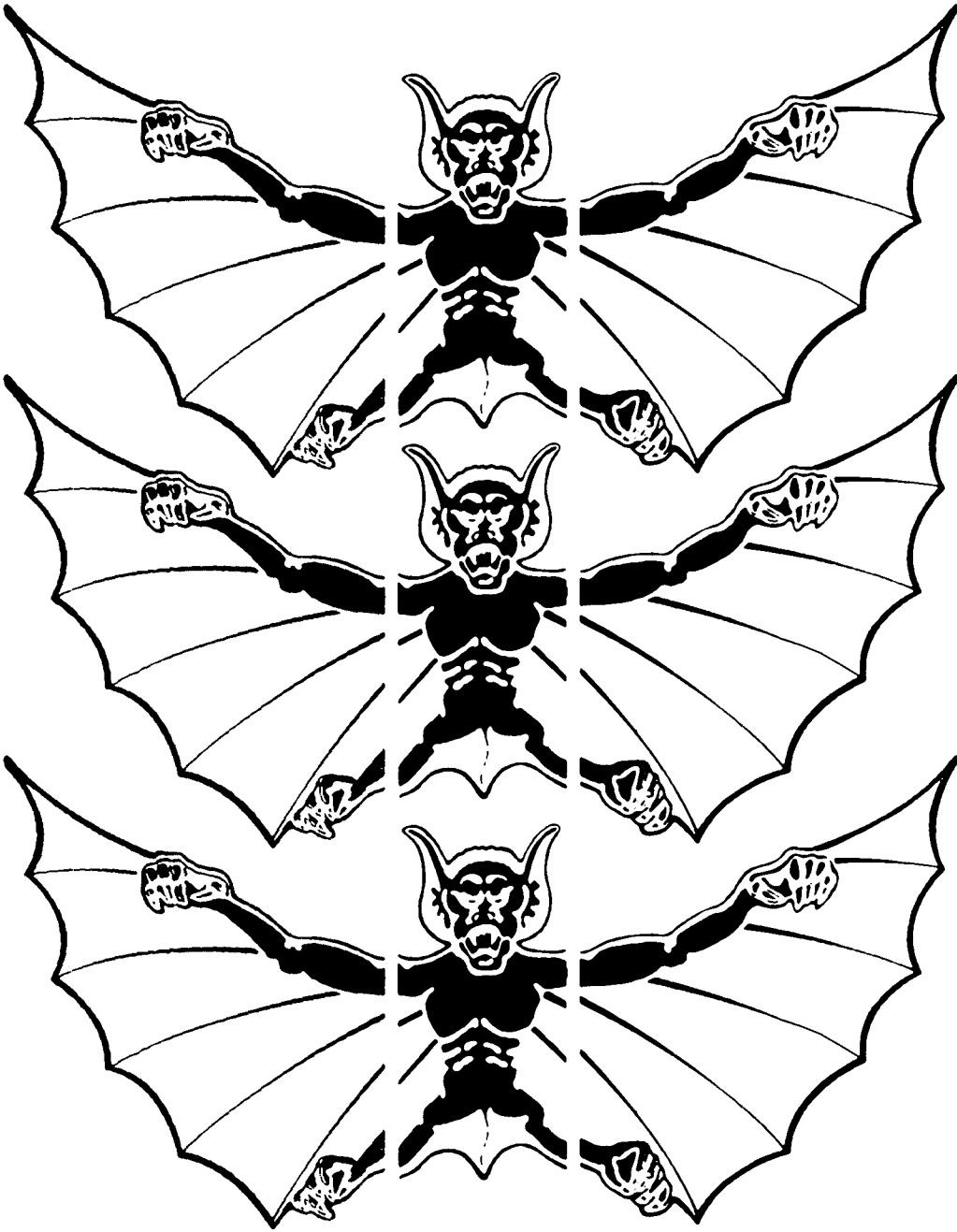

THE BAT

Redrawn By:
James Zalewski (JimZ)

3 part Bats

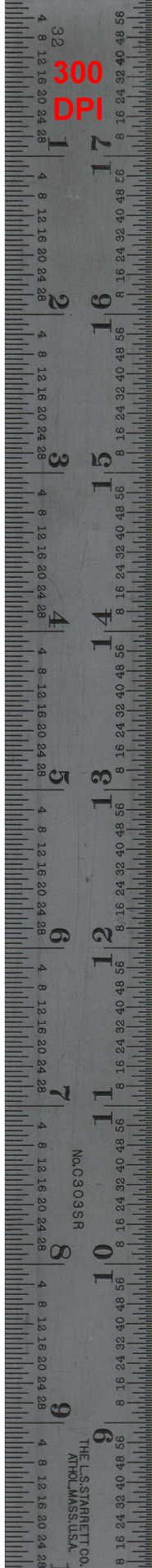

No.0303SH

THE L.S. STARNETT CO.
ATHOLMASS, USA.

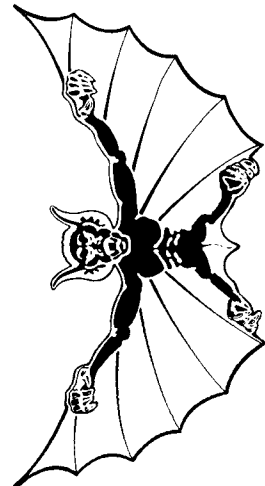
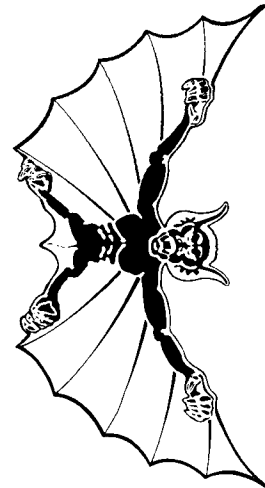
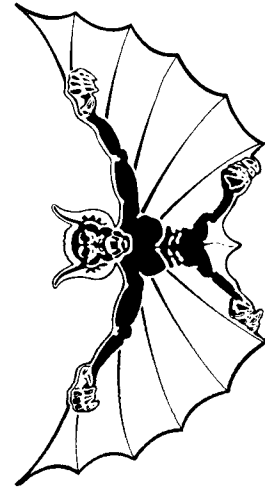
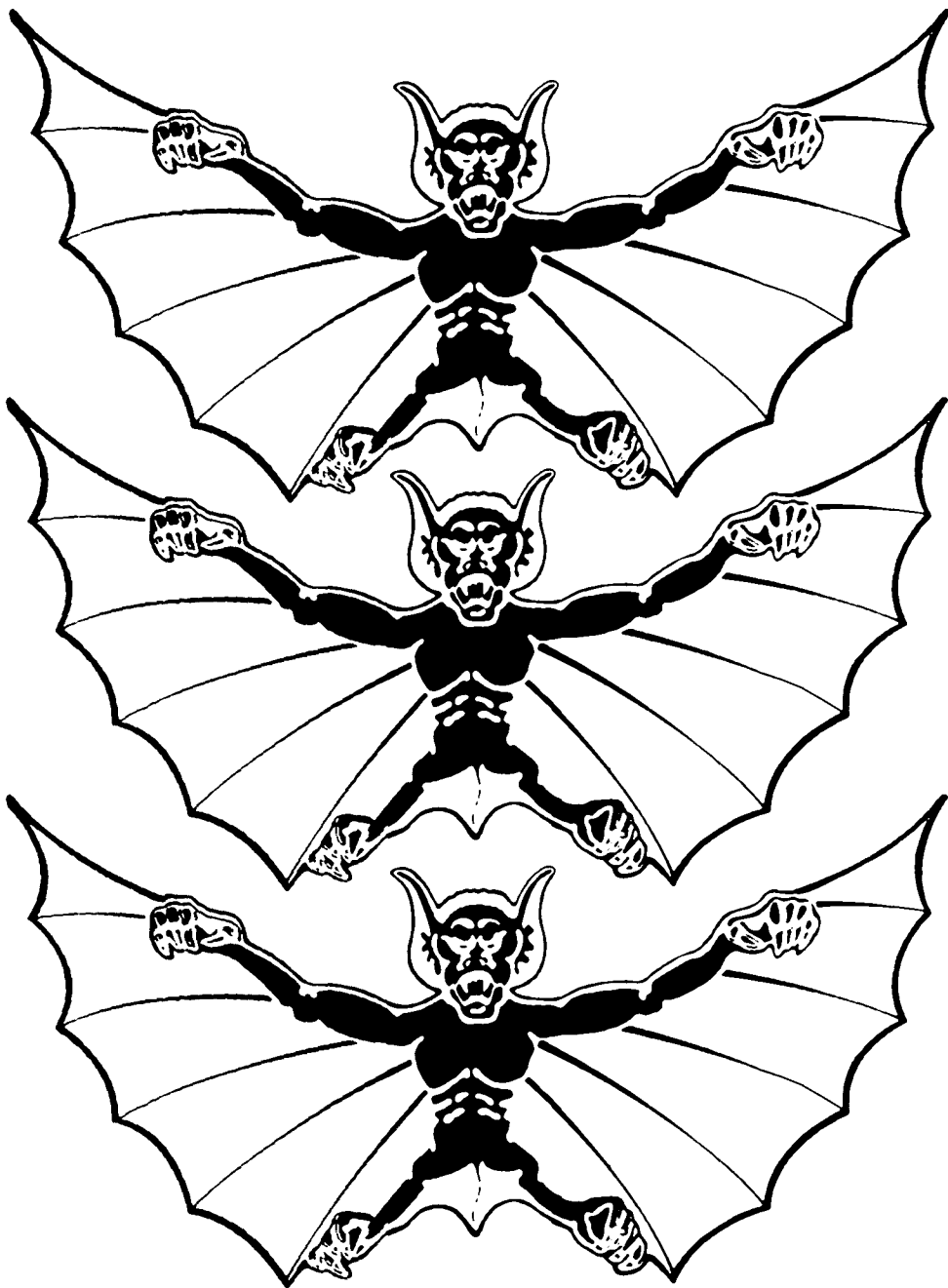

THE BAT

Redrawn By:
James Zalewski (JimZ)

1 part Bats

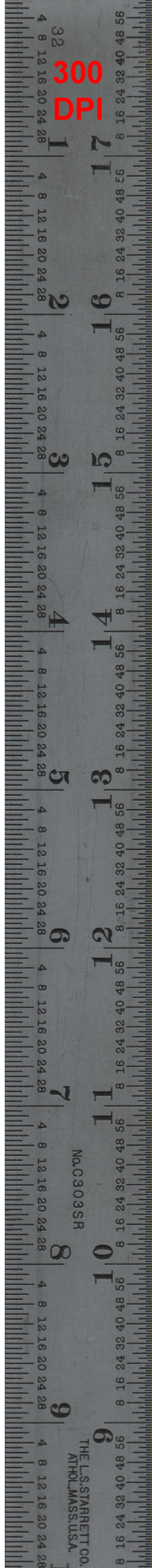

3/32"

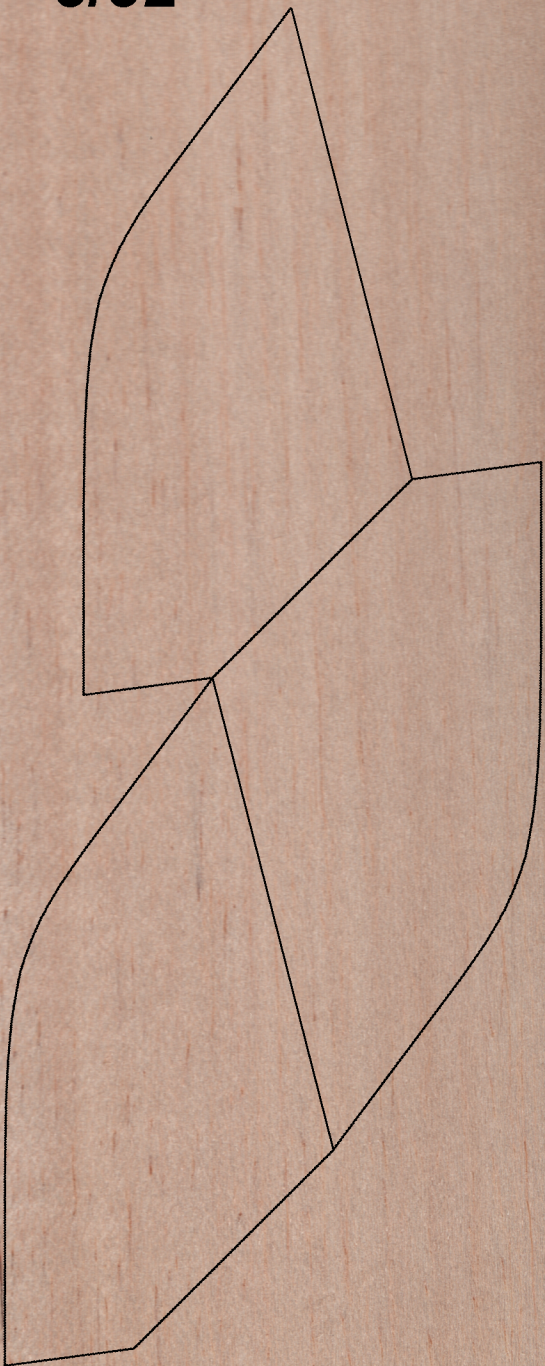

32
4 8 12 16 20 24 28
1
4 8 12 16 20 24 28
2
4 8 12 16 20 24 28
3
4 8 12 16 20 24 28
4
4 8 12 16 20 24 28
5
4 8 12 16 20 24 28
6
4 8 12 16 20 24 28
7
4 8 12 16 20 24 28
8
4 8 12 16 20 24 28
9

1
2
3
4
5
6
7
8
9

300
DPI

No.C303SR

THE BAT

ESTES, IND. PN 37588

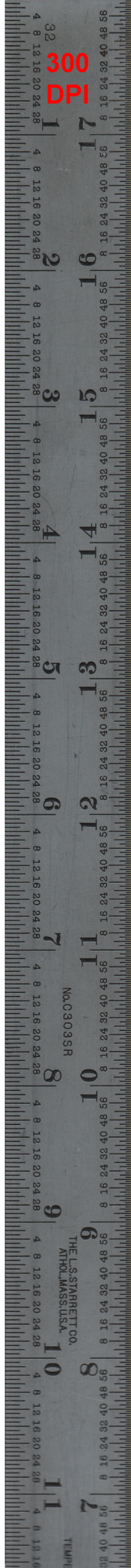

300
DPI

No. C303SR

THE L.S. STARETT CO.
ANHOLM, MASS., U.S.A.

TEMPERATURE

inch scale

2

1

0

1

2

3

4

5

6

2

1

0

1

2

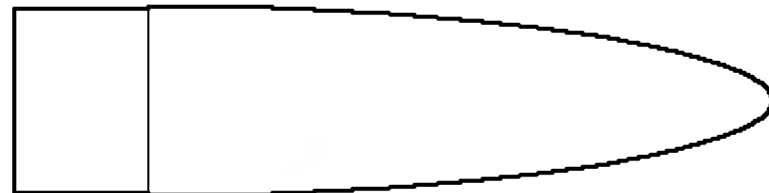

Material: Balsa

Fits T50 tube with
 ID= .95 OD= .976
 Overall length: 4
 Exposed length: 3.3
 Shoulder length: .7

all dimensions are in inches unless otherwise specified.

Part is drilled for, and supplied with, a 1/4 inch hardwood dowel drilled to accept a screw eye.

Balsa Machining Service

This print is the property of Balsa Machining Service. It may be copied and distributed if done in it's entirety. Although BMS considers this drawing proprietary it makes no claim whatsoever regarding the cone shape itself.

Size A	Part Number BNC50X	REV A
Date 12/20/06	Tool: 50x	Sheet 1 of 1

PARTS LIST KIT NO. 1362 - The Bat

Quantity	Description	Type	Number	Detail1	Detail2	Detail3	Detail4	Comment
	PAPER BODY TUBE	BT-20J	30326	2.75" long	0.710" ID	0.736" OD	0.013" wall	Glassine
	ENGINE HOLDER	EH-2	35025	2.8" long	.100" wide	.025" thick		Reg. & D
	MYLAR RETAINER RING	HR-20	30168	0.3" long	0.74" ID	0.76" OD	0.01" wall	BT-20
	SPLIT ADAPTER RING	AR-2050S	80425	1/4" long	.737" ID	.949" OD	0.106" wall	Green
	ADAPTER RING	AR-2050	30164-2	1/4" long	.737" ID	.949" OD	0.106" wall	Green
	BALSA FIN STOCK	*BFS-30	3168	3" wide	9" long	3/32" thick	0.09375	Scan
	Pattern Sheet	SP-50A	83332	3" wide	3.5" long	Cardstock		Scan
	PAPER BODY TUBE	BT-50L	30366	12.7" long	0.950" ID	0.976" OD	0.013" wall	Glassine
	LAUNCH LUG	LL-2A	38175	5/32" ID	1/8" rod	1.25" long		Mylar
	Shock Cord	SC-1	85730	18" long	1/8" wide			Rubber
	BALSA NOSE CONE	BNC-50X	71010	3.25" long	.976" dia.	.5" shoulder		Old #70264
	Paper Streamer Material	SM-1C	38273	1" wide	90" long	Red	Crepe Paper	Flame Resistant
	Tape Disc	TD-1	38401	3/4" dia.	Paper	Self-Stick		
	Decal Sheet	KD-1362	37588	8" wide	10" long	White	Waterslide	Scan
	Shock Cord Mount	SCM-50	84444	1.5" wide	3" long	Heavy paper		Scan

*Die-Cut Balsa Sheet (type BF-1362) #32365