

S.S. CASSIOPEIA

SKILL LEVEL 3 – Recommended for Craftsman Rocketeers.

RECOMMENDED ENGINES:
 B4-2 B4-4 B6-2 B6-4
 B8-5 C6-5 C6-7

BEFORE YOU START

Read all instructions before beginning construction on your model. Make sure you have all parts and materials. When you are thoroughly familiar with the assembly procedure, begin construction. Check off each step as you complete it. In each step, test-fit the parts together before applying any glue. If some part doesn't fit properly, sand lightly or build up as required for precision assembly.

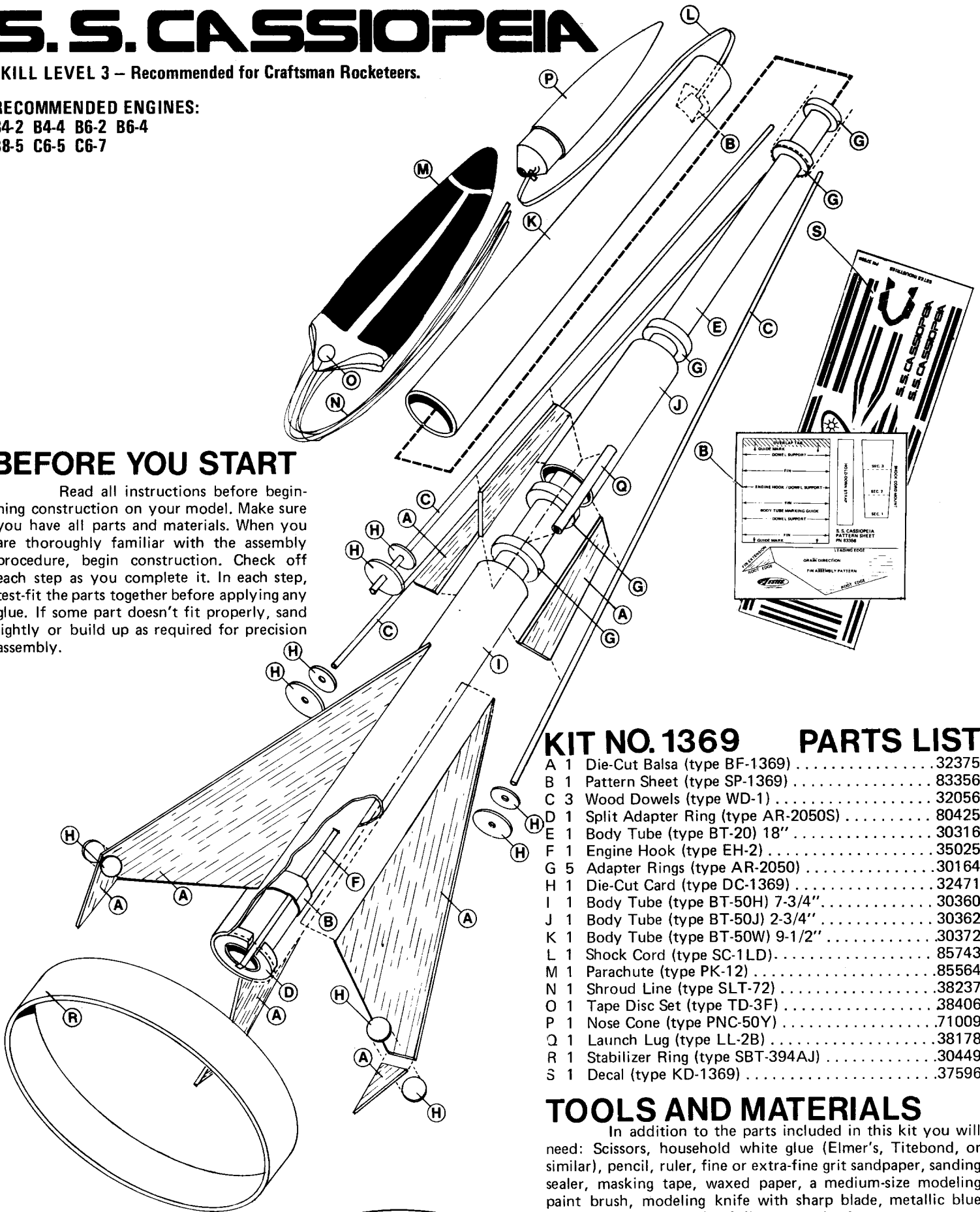

KIT NO. 1369 PARTS LIST

A	1 Die-Cut Balsa (type BF-1369)	32375
B	1 Pattern Sheet (type SP-1369)	83356
C	3 Wood Dowels (type WD-1)	32056
D	1 Split Adapter Ring (type AR-2050S)	80425
E	1 Body Tube (type BT-20) 18"	30316
F	1 Engine Hook (type EH-2)	35025
G	5 Adapter Rings (type AR-2050)	30164
H	1 Die-Cut Card (type DC-1369)	32471
I	1 Body Tube (type BT-50H) 7-3/4"	30360
J	1 Body Tube (type BT-50J) 2-3/4"	30362
K	1 Body Tube (type BT-50W) 9-1/2"	30372
L	1 Shock Cord (type SC-1LD)	85743
M	1 Parachute (type PK-12)	85564
N	1 Shroud Line (type SLT-72)	38237
O	1 Tape Disc Set (type TD-3F)	38406
P	1 Nose Cone (type PNC-50Y)	71009
Q	1 Launch Lug (type LL-2B)	38178
R	1 Stabilizer Ring (type SBT-394AJ)	30449
S	1 Decal (type KD-1369)	37596

TOOLS AND MATERIALS

In addition to the parts included in this kit you will need: Scissors, household white glue (Elmer's, Titebond, or similar), pencil, ruler, fine or extra-fine grit sandpaper, sanding sealer, masking tape, waxed paper, a medium-size modeling paint brush, modeling knife with sharp blade, metallic blue spray paint, and a bottle of silver enamel paint.

For easy and positive alignment of the fins on your model, we recommend the use of Estes' Fin Alignment Guide, Part No. 2231.



ASSEMBLY INSTRUCTIONS

1

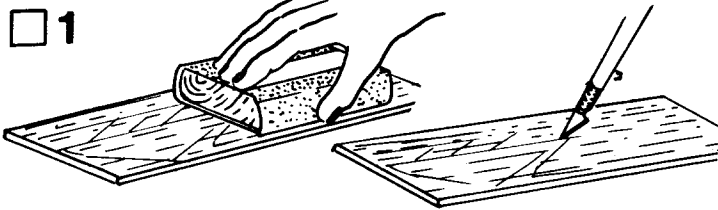

Fine-sand both sides of balsa sheet (part A), then carefully remove the fin parts using a sharp knife to free the edges. Sand the edges of the parts slightly to remove any rough edges, being careful to leave the edges square and sharp-cornered.

2

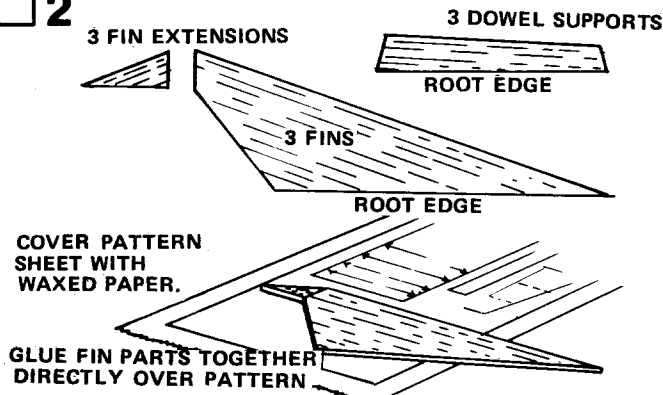

Sort and identify parts as shown. Make sure all mating edges match. Rub a line of glue into the mating edges of fins and fin extensions. Cover fin assembly pattern on pattern sheet (part B) with waxed paper and apply a second bead of glue to the mating edges and press fin parts together and in correct position over the fin pattern. Wipe away excess glue and set fins aside to dry. Repeat assembly steps for other two fins.

3

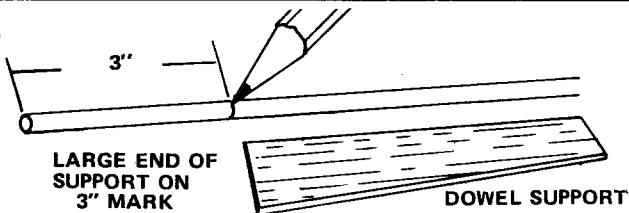

Cut the three wood dowels (part C) to 14" lengths. Mark each dowel 3" from one end and glue a dowel support to each dowel as shown. Temporarily tape each dowel in position with a short piece of masking tape until glue sets. DO NOT wait till glue is completely dry or tape will stick.

4



Glue the split adapter ring (part D) to one end of the 18" body tube (part E). This end is the rear of the rocket. The rear of the ring should be even with the rear of the tube. Wipe excess glue out of slot.

5

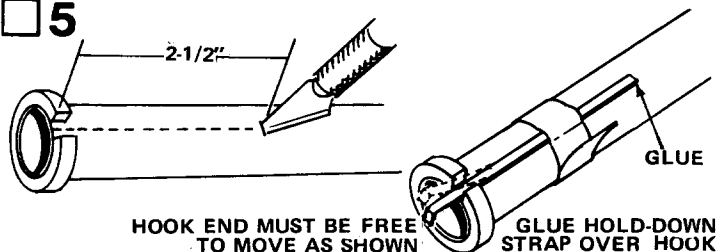

Cut a 1/8" slit in the body, directly in line with the gap in the split adapter ring, 2-1/2" from the end of the body. Cut out the hold-down strap from the pattern sheet. Insert one end of the engine hook (part F) into the slit and lay the hook along the body so the

other end passes through the gap in the split ring. Smear glue over one side of the hold-down strap and wrap it around the body, centered over the hook. Apply a drop of glue over the forward end of the engine hook.

6

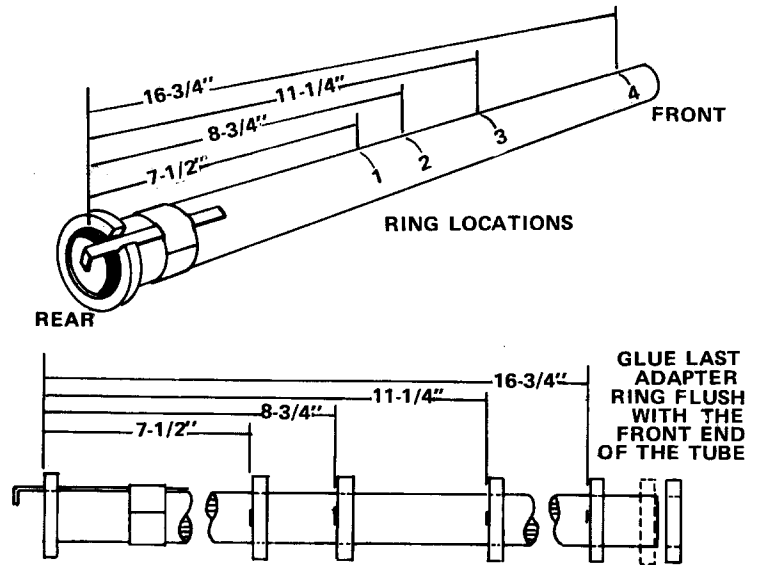

Mark the tube for the rear locations of the five adapter rings (part G). Mark the tube at 7-1/2", 8-3/4", 11-1/4", and 16-3/4" from the rear of the tube. Start with the ring position nearest the rear, apply a line of glue around the tube about 1/4" in front of the 7-1/2" mark. Slide a ring onto the tube from the front and slide it back until the rear of the ring is on the mark. Repeat at the 8-3/4", 11-1/4", and 16-3/4" locations and finally glue the last ring even with the front of the tube.

7

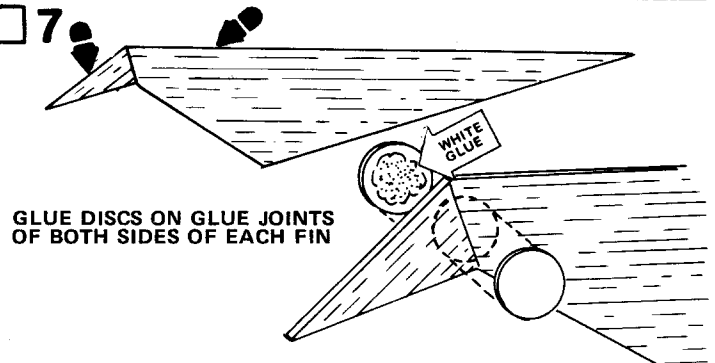

When glue has thoroughly dried on the fin assemblies, lightly sand. Sand round the edges indicated. Leave all other edges square. Glue the six discs from the die-cut card (part H), as shown. Glue one disc on each fin/fin extension joint and one more disc identically on opposite side of the joint.

8

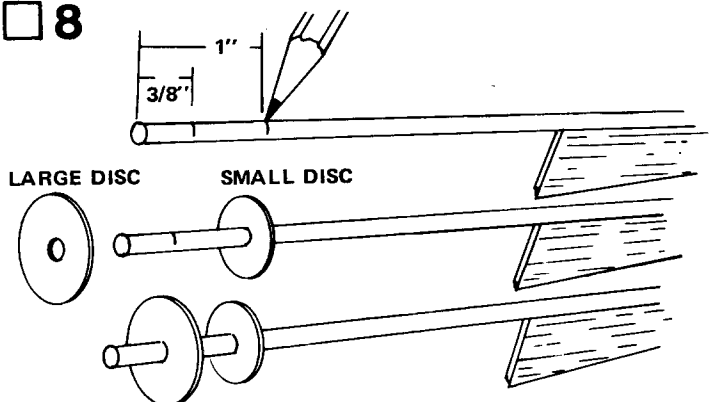

Mark the dowel/dowel support assemblies as shown. Glue small discs to the dowels at the 1" mark, then glue large discs to the dowel on the 3/8" marks as shown.

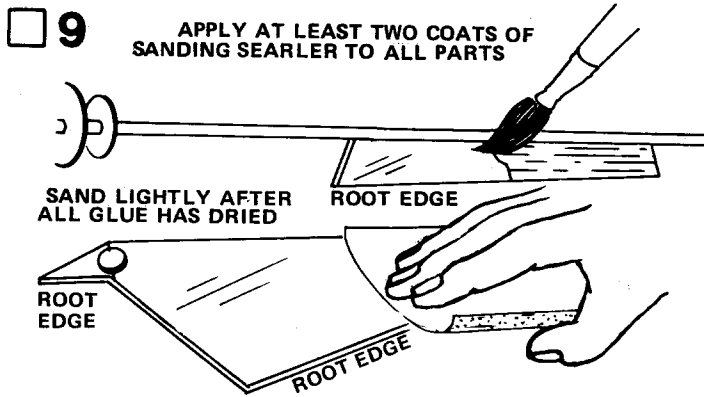

When glue has thoroughly dried on the fin and dowel support assemblies, apply a coat of sanding sealer to all surfaces of parts except root edges (edge that glues to the body). Allow sealer to dry, then lightly sand parts. Repeat sealing and sanding steps a second time. Repeat until the tiny grain lines in the wood are filled and everything looks and feels smooth.

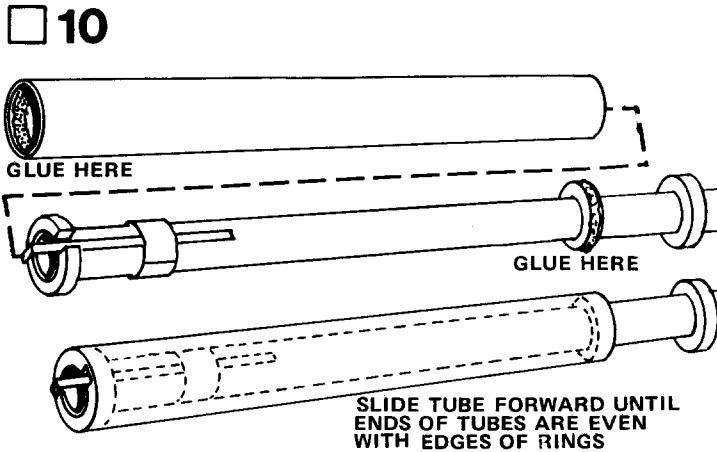

From the rear, slide the 7-3/4" long body tube (part I) onto the split ring and almost to the next ring. Apply glue around the inside of the rear end of the tube. Apply glue around the exposed outer surface of the ring in front of the tube. Slide the tube forward until the ends of the tube are even with the edges of the rings as illustrated. Wipe away excess glue.

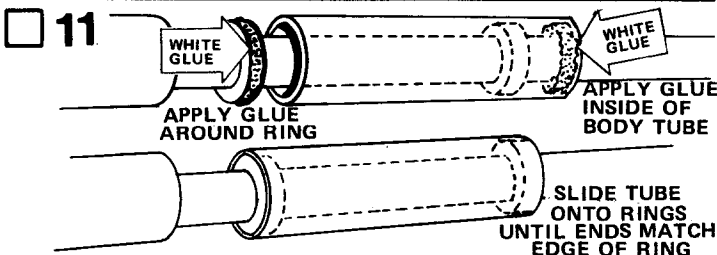

From the front, slide the 2-3/4" long body tube (part J) onto the forward ring and almost to the next ring. Use a toothpick or short dowel scrap to apply a ring of glue just inside the front end of the tube. Apply glue around the outside of the second ring. Slide the tube back until the ends of the tube are even with the edges of the rings as shown. Wipe away excess glue.

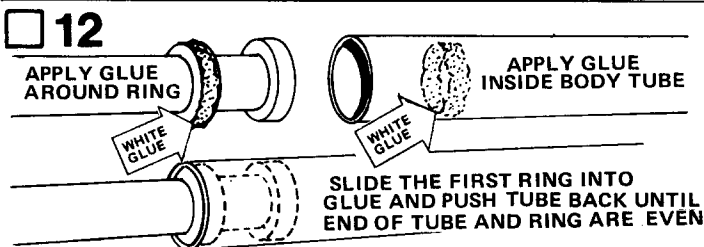

Smear glue around the inside of one end of the 9-1/2" long body tube (part K). Apply glue around the outside of the ring as shown.

Slide the first ring into the glue inside the body tube, and push the tube back until the end of the tube is even with the edge of the ring as shown. Wipe away excess glue.

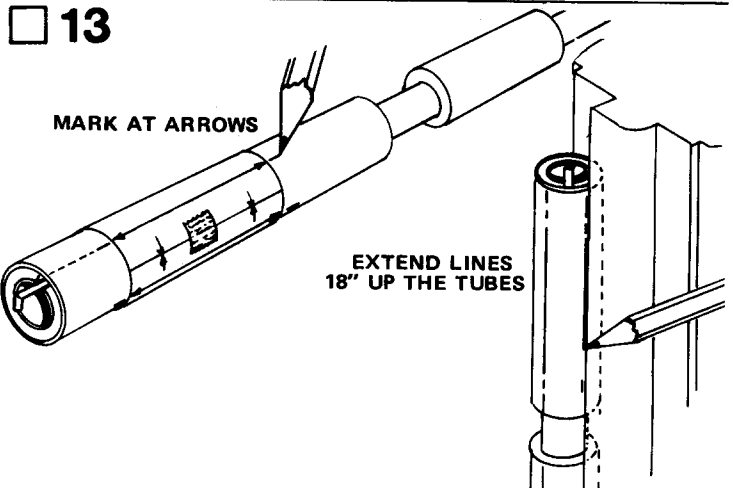

Cut out the tube marking guide from the pattern sheet. Wrap it around the rear tube and align the engine hook with the arrow point on the marking guide labeled "Engine Hook Dowel Support". Mark the tube at each arrow point as shown. Use the edge of a door frame as a guide to draw a straight connecting line between each matching pair of marks. Extend the fin lines the length of the 7-3/4" tube, extend the dowel support lines up 18" the length of the rocket.

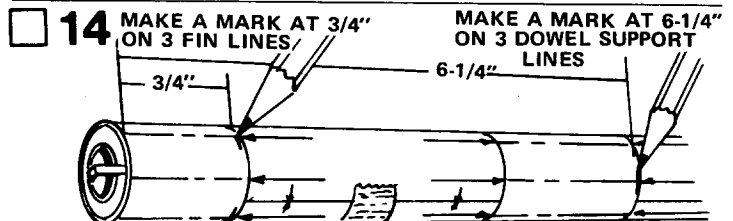

Re-wrap the marking guide around the tube and slide the guide up the tube until the rear of the guide is 3/4" from the rear of the body tube. Mark all three fin alignment lines at this distance as shown. Slide the marking guide up the tube until the rear of the guide is 6-1/4" from the rear of the body tube. Mark the dowel support alignment lines at this distance.

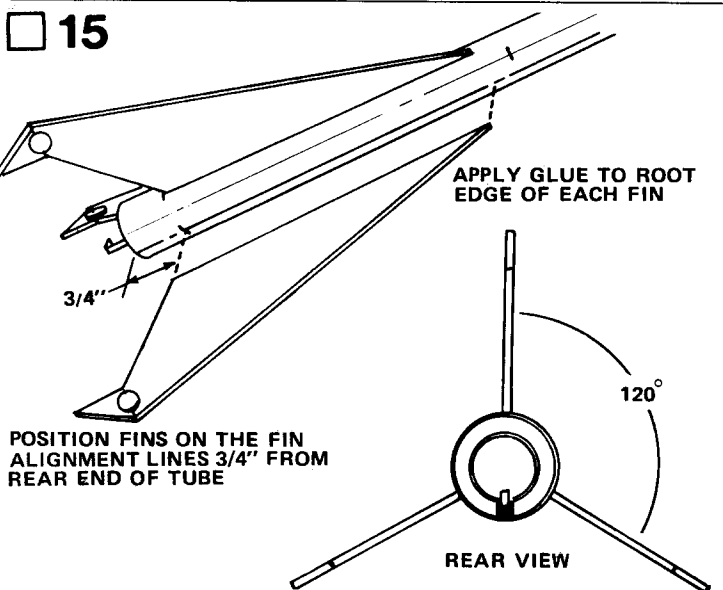

Rub a line of glue into the root edge of each fin and allow glue to dry. Apply glue to the fins root edges and position fins on their alignment lines with the rear of each fin on the 3/4" mark. Adjust the fins so they project straight away from the body tube. DO NOT set the rocket on its fins while the glue is wet.

16

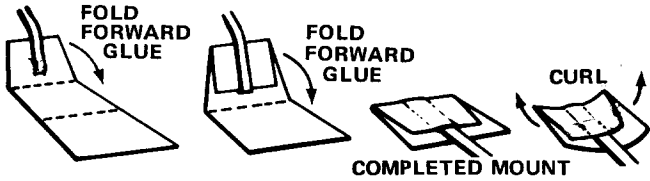

Cut out the shock cord mount from the pattern sheet. Fold on dotted lines, then unfold and apply glue to Section 1. Lay the end of the shock cord (part L) into the glue. Fold over and apply glue to the back of Section 1 and the exposed portion of Section 2. Fold again to complete mount. Curl the edges of the mount up so it will match the contour of the body tube and hold with your fingers until the glue sets.

17

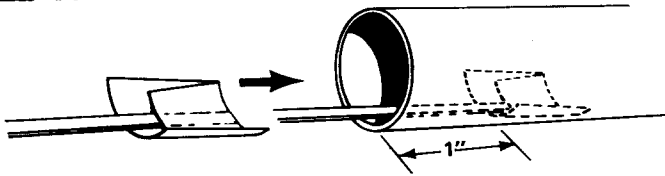

Use a stick or scrap dowel to apply a generous amount of glue inside the body tube 1" from the front edge of the tube to allow clearance at the front of the tube for the nose cone to socket into place. Slide the shock cord mount into the tube and press it into the glue. To ensure a good bond use a stick or your finger to smear a film of glue over the mount and surrounding area in the body tube.

18 GLUE DOWEL SUPPORTS CENTERED ON ALIGNMENT LINES 6-1/4" FROM END OF THE TUBE

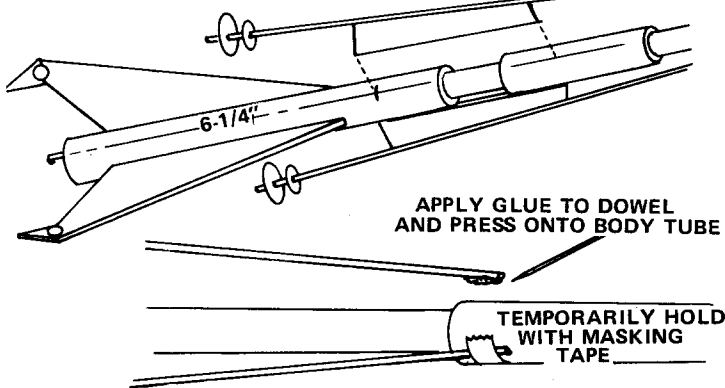

Rub a line of glue into the root edge of each dowel support and allow to dry. Apply glue to the dowel supports and position the rear edge of the support on the 6-1/4" mark and centered on the support center line. Adjust the supports so they project straight away from the body tube. After the glue has set, apply glue to the front portion of the dowel where it contacts the body tube. Press the dowel and glue onto the body tube, centered on the support alignment lines. Temporarily tape each dowel in position with a short piece of masking tape until glue sets. Do not wait till glue is completely dry to remove tape.

19

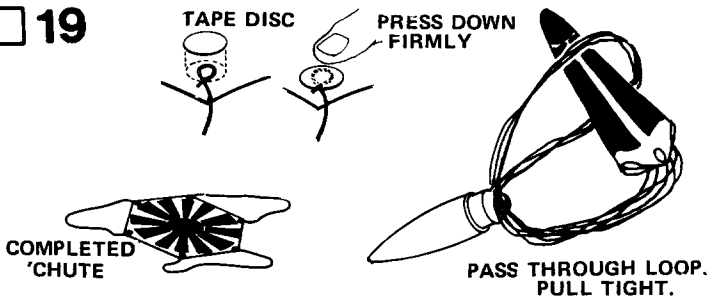

Cut out the parachute (part M) on its edge lines. Cut the shroud line (part N) into three equal lengths. Form a small loop in one end

of a shroud line and attach to a corner of the 'chute with a tape disc (part O). Press the tape disc down very firmly over the line. Attach the opposite end of the shroud line to an adjacent corner of the 'chute. Attach the remaining shroud lines in the same manner. Pass the shroud line loops through the "eye" of the nose cone (part P). Open the three loops and pass the 'chute through and draw the lines tight. Tie free end of the shock cord to nose cone. Pack parachute and shock cord into rocket body. Slide nose cone into place.

20

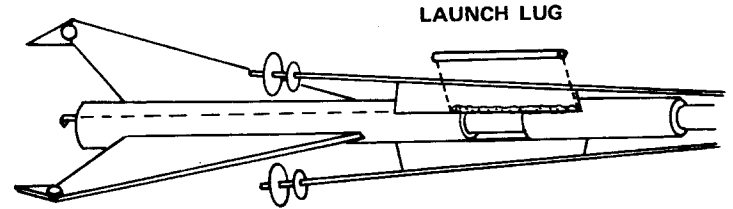

Locate the dowel support that is in line with the engine hook. Apply glue along one edge of the launch lug (part Q) and press launch lug and glue against dowel support and body tube. The front of the launch lug should be even with the front of the dowel support.

21

APPLY GLUE ON INSIDES OF FIN EXTENSIONS

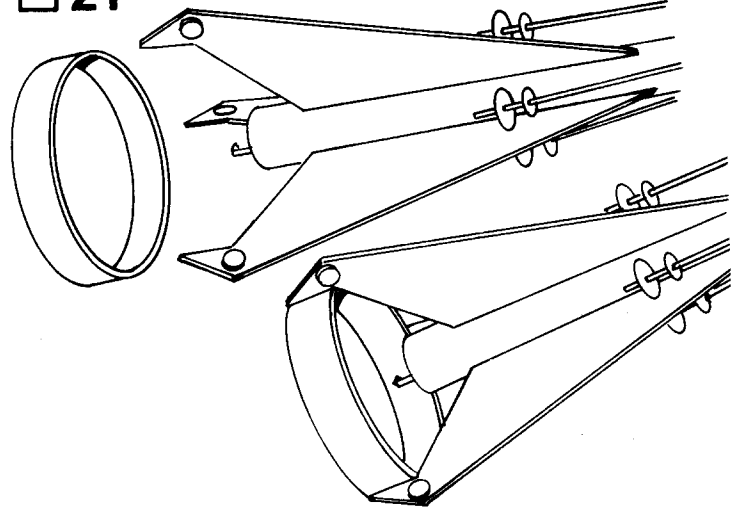

Test-fit the stabilizer ring (part R) inside the fin extensions as shown. Sand or build-up contact area on fins if necessary for proper fit. Remove the stab ring and apply a line of glue to the inside edges of the fin extensions. Slide stab ring between the fin extensions and wipe away any excess glue.

22

APPLY GLUE REINFORCEMENT TO EACH JOINT WHERE A WOOD PART CONNECTS TO ANOTHER WOOD PART OR TUBE PART.

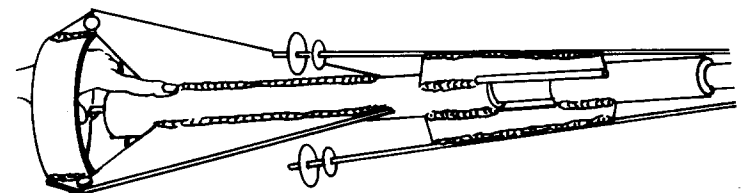

When the glue on the fin joints and dowel supports has dried, apply a glue reinforcement to each joint where a wood part connects to another wood part or tube part. Holding the model level, apply a line of glue to both sides of each joint. Smooth out the glue with your finger. **IMPORTANT** -- Keep the model level until the glue dries.

PAINING

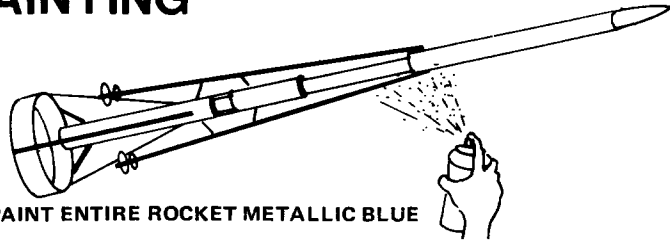

PAINT ENTIRE ROCKET METALLIC BLUE

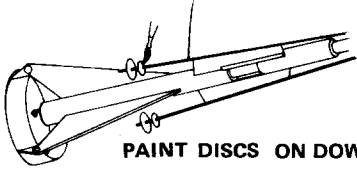

PAINT DISCS ON DOWELS SILVER

Before painting, clean the rocket with a slightly damp cloth to remove oily fingerprints. The entire rocket is painted metallic blue. We recommend Pactra metallic blue spray enamel. DO NOT paint the model with lacquer paint. Lacquer will mar the finish of the plastic nose cone. Spray the model with several light coats of paint to avoid "runs". Paint discs on dowels with a paint brush and a bottle of chrome silver enamel paint. Allow the rocket to dry for 2 to 4 hours before applying the decals.

DECAL PLACEMENT

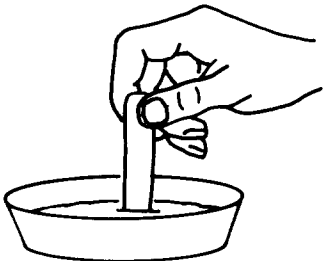

SUBMERGE DECAL IN WATER FOR 15 - 30 SECONDS

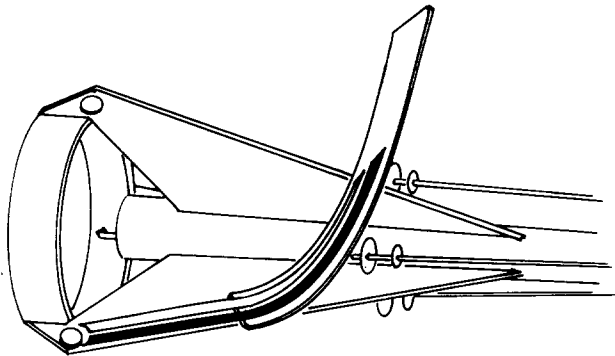

GENTLY SLIDE DECAL FROM BACKING PAPER ONTO MODEL

Apply the decals (part S) in positions shown in photographs. To apply decals, cut only one decal at a time from the sheet. Submerge decal in water for 15 to 30 seconds (until decal slides on backing paper). Gently slide decal from backing paper onto the model. Move decal into exact position and carefully blot away excess water with a soft cloth. If the decal "sticks" before you have it in position, apply water over the decal with a brush. This will permit the decal to be moved. Smooth out all wrinkles and air bubbles before the decal dries. We recommend that the completed model be sprayed with Testor's "DullCote". This is a clear flat spray paint that kills the decal shine and protects the models finish.

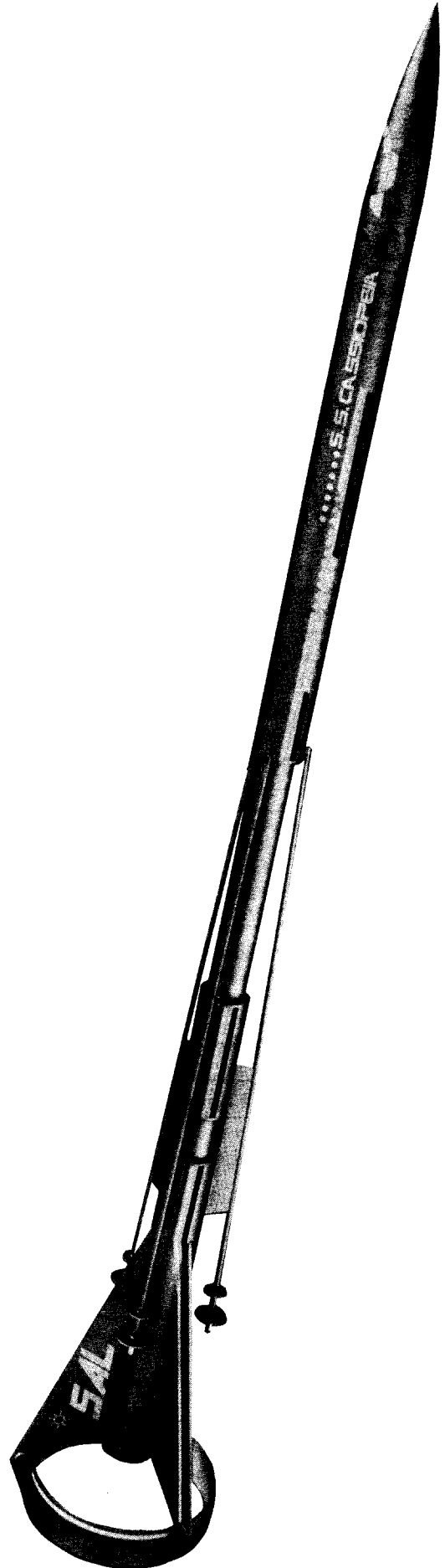

LAUNCHING COMPONENTS

To launch your rocket you will need the following items:
 An Estes model rocket launch system
 Parachute recovery wadding (Estes Cat. No. 2274)
 Recommended Engines: B4-2, B4-4, B6-4, B6-4, B8-5,
 C6-5, C6-7. Use a B6-4 engine for your first flight.

Be sure to follow the HIAA-NAR* Model Rocket Safety Code when carrying out your model rocket activities.
 *HIAA -- Hobby Industry Association of America
 NAR -- National Association of Rocketry

COUNTDOWN CHECKLIST

T-13 Pack 4 or 5 squares of loosely crumpled recovery wadding into the body tube.

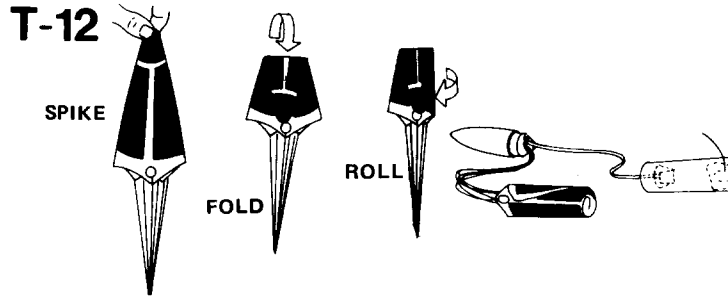

Hold the parachute at its center and pass the other hand down it to form a "spike" shape. Fold this spike in half. Roll parachute into tube shape to fit easily into body. Pack 'chute into the tube on top of the wadding. Pack the shroud lines and shock cord in on top of the parachute and slip the nose cone into place.

NOTE: DO NOT pack parachute until you are actually ready to launch. For maximum parachute reliability, lightly dust the 'chute with ordinary talcum powder before each flight, especially in cold weather.

NOTE: Nose cone should separate easily from rocket body tube, but should not be extremely loose. If fit is too tight, sand inside of body tube and shoulder of nose cone with fine sandpaper. If fit is too loose, add a wrapping of transparent tape or masking tape to the shoulder of the nose cone.

T-11 Select an engine and install an igniter as directed in the engine instructions. Use a B6-4 engine for your first flight.

T-10 Insert engine into rocket engine mount. Engine hook must latch securely over end of the engine.

T-9 Disarm the launch panel -- REMOVE SAFETY KEY!

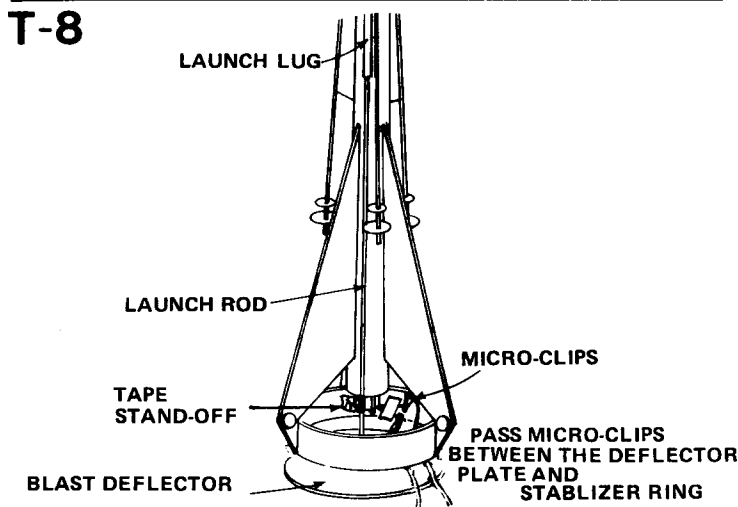

Slide the launch lug of rocket onto the launch rod. Make sure the rocket slides freely on the launch rod. If the launch pad you are

using does not have a rocket stand-off, place a piece of masking tape on rod as shown to keep rocket 1" above the deflector plate. Clean the micro-clips, pass them between the deflector plate and stabilizer ring of rocket, and attach them to the igniter wires as close to engine nozzle as possible. Arrange the clips so they do not touch each other or the metal blast deflector.

T-7 Clear the launch area, alert recovery crew and trackers. Check for low flying aircraft and unauthorized persons in the recovery area.

T-6 Arm the launch panel -- INSERT SAFETY KEY!

-5-4-3-2-1-LAUNCH!!

Repeat Countdown Checklist for each flight.

MISFIRE PROCEDURE

Occasionally the igniter will heat and burn into two pieces without igniting the engine. This is almost always caused by a failure to install it correctly. REMOVE SAFETY KEY from launch panel, remove the model, clean the igniter residue from the engine nozzle, and install a new igniter. Repeat the Countdown Checklist.

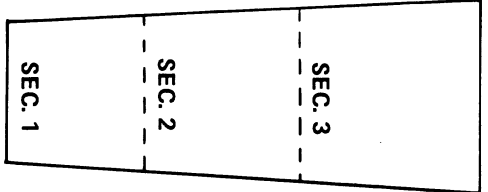
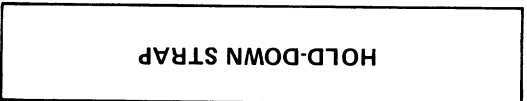
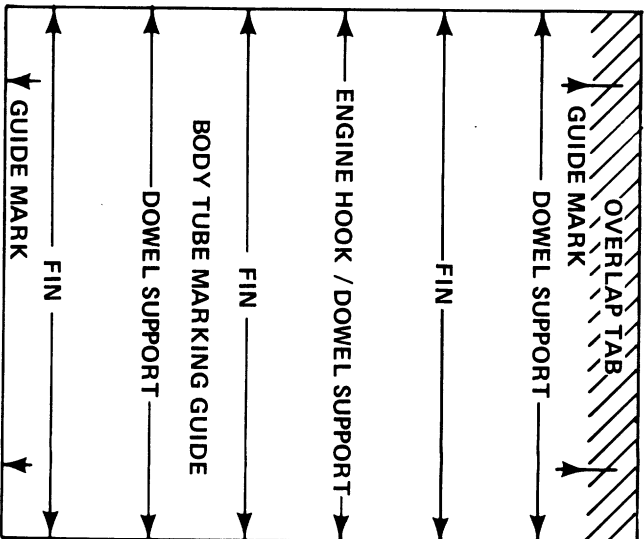

SHOCK CORD MOUNT

S. S. CASSIOPEIA
 PATTERN SHEET
 PN 83356

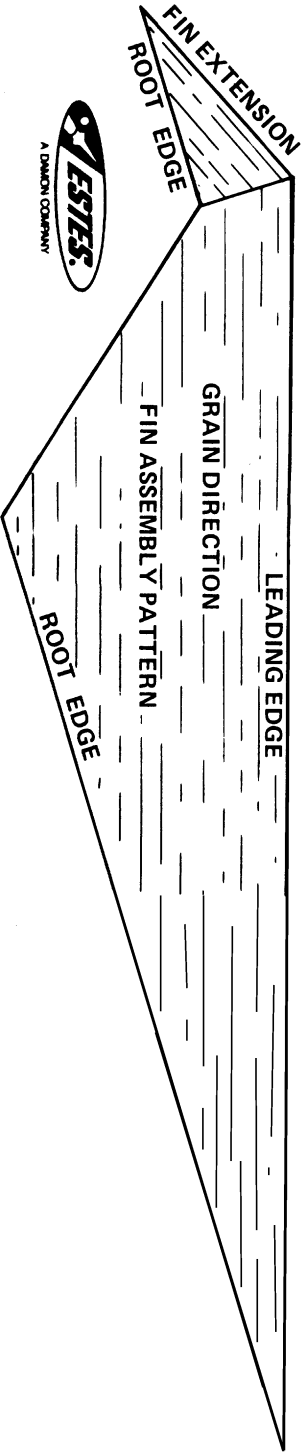

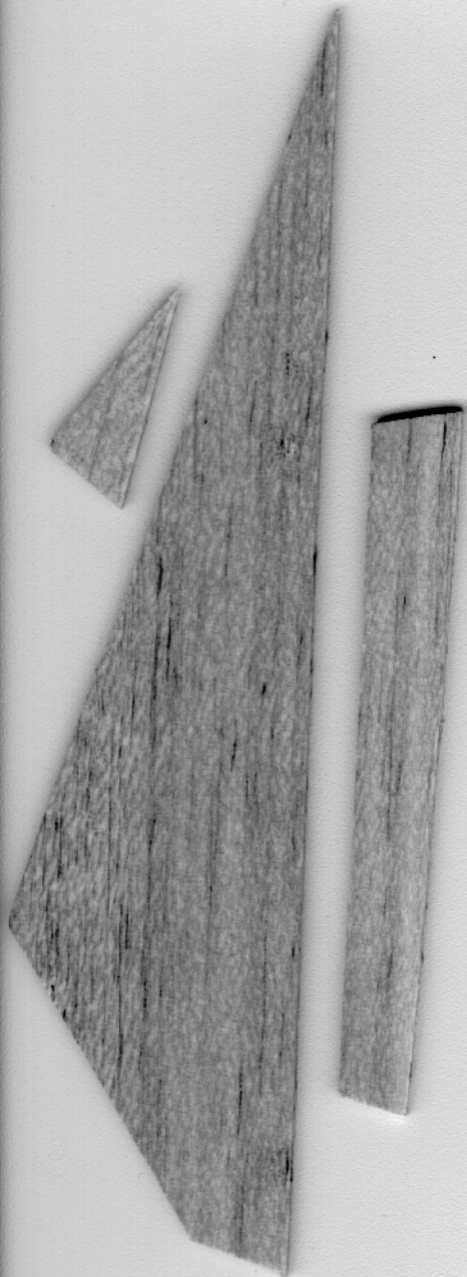

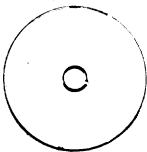
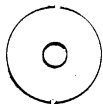
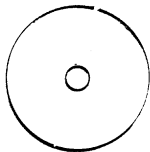
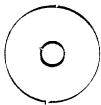
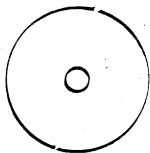
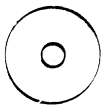

111111

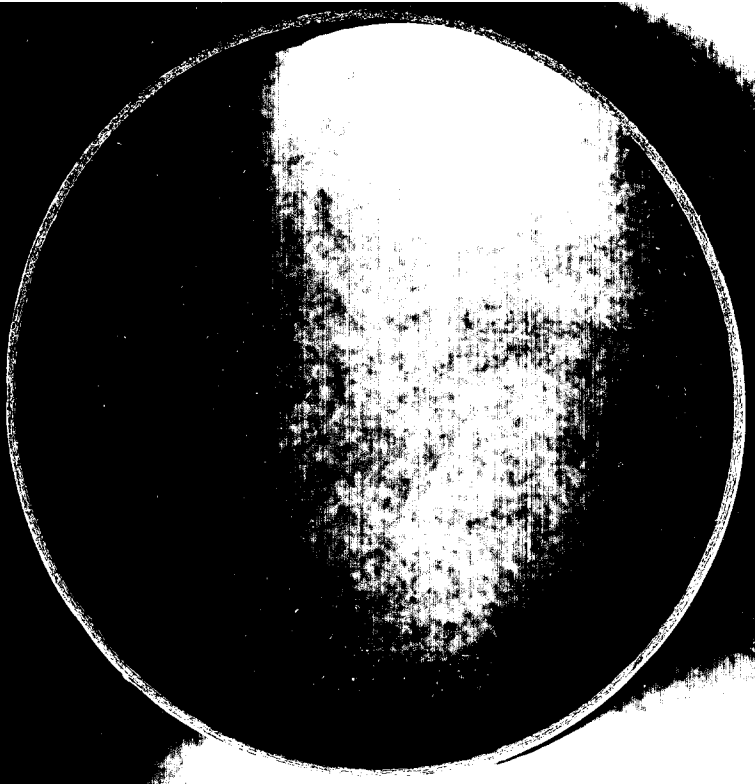

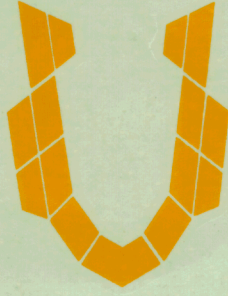

S. S. CASSIOPEIA

S. S. CASSIOPEIA

