

# BEFORE YOU START

Read all instructions before beginning construction on your model. Make sure you have all parts and materials. When you are thoroughly familiar with the assembly procedure, begin construction. Check off each step as you complete it. In each step, test-fit the parts together before applying any glue. If some part doesn't fit properly, sand lightly or build up as required for precision assembly.

# alien explorer

SKILL LEVEL 3 – Recommended for Craftsman Rocketeers.

RECOMMENDED ENGINES:  
B6-2 B6-4 B8-5 C6-5

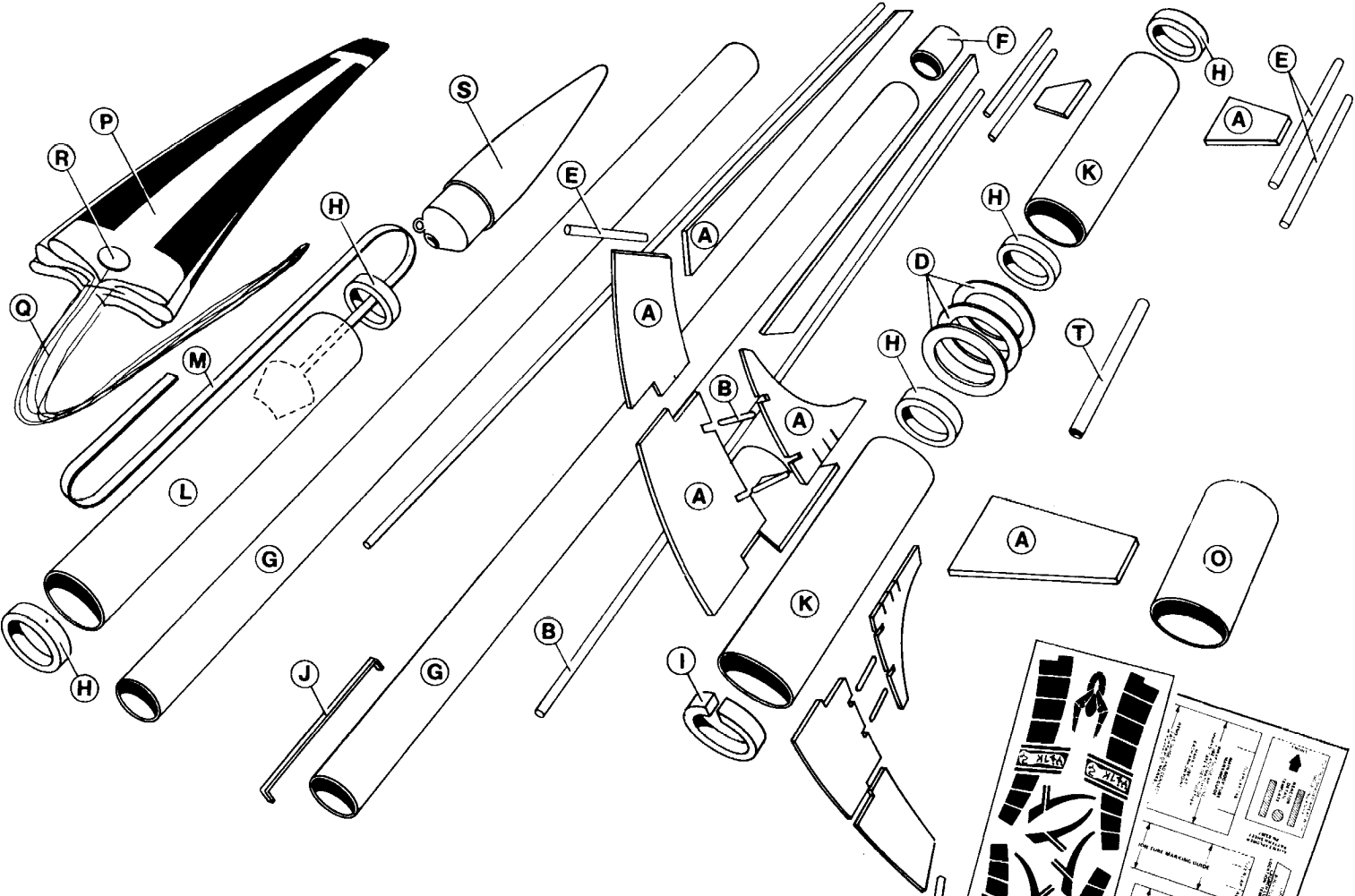

## TOOLS AND MATERIALS

In addition to the parts included in this kit you will need: Scissors, household white glue (Elmer's, Titebond, or similar), pencil, ruler, fine or extra-fine grit sandpaper, sanding sealer, a medium-size modeling paint brush, modeling knife with sharp blade, masking tape, chromate green enamel spray paint, and a bottle of red enamel paint.

## PARTS LIST

## KIT NO. 1372

A	2 Die-Cut Balsa Sheets (type BH-1372) (3/32" Thick)	32378
B	2 18" Long Wood Dowel (type WD-1) (1/8" Dia.)	32056
C	1 Pattern Sheet (type SP-1372)	83367
D	1 Die-Cut Card (type TA-73)	30055
E	1 12" Long Wood Dowel (type WD-2) (1/12" Dia.)	32058
F	1 Tube Coupler (type JT-20C) (3/4" Long)	30254
G	2 Body Tubes (type BT-20) 18"	30316
H	5 Adapter Rings (type AR-2050)	30164
I	1 Split Adapter Ring (type AR-2050S)	80425
J	1 Engine Hook (type EH-2)	35025

K	2 Reactor and Secondary Body Tubes (type BT-50S) 4"	30368
L	1 Parachute Compartment Tube (type BT-50H) 7-3/4"	30360
M	1 Shock Cord (type SC-1)	85730
N	1 Shock Cord Mount (type SCM-50)	84444
O	2 Ion Tubes (type BT-50AH) 1-7/8"	30356
P	1 Parachute (type PK-18)	85566
Q	1 Shroud Line (type SLT-108)	38239
R	1 Tape Disc Set (type TD-3)	38406
S	1 Nose Cone (type PNC-50X)	71010
T	1 Launch Lug (type LL-2B)	38178
U	1 Decal (type KD-1372)	37599

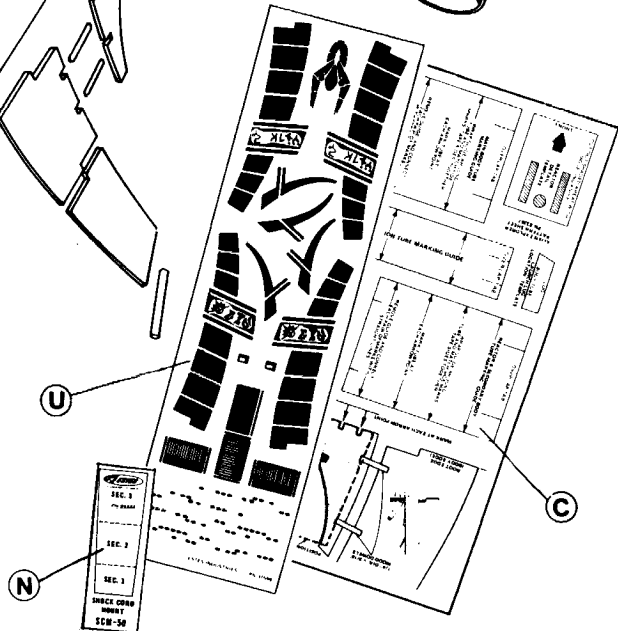

Page 2  
**ASSEMBLY INSTRUCTIONS**

1

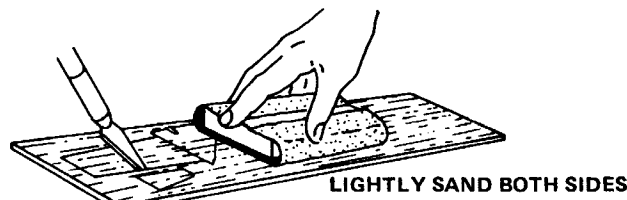

Fine-sand both sides of the die-cut balsa sheets (parts A). Carefully remove the die-cut fins and parts from the sheets. Free the edges with a sharp knife. Sand the edges of the parts slightly to remove any rough edges being careful to leave the edges square and sharp-cornered.

2

SAIL HALVES

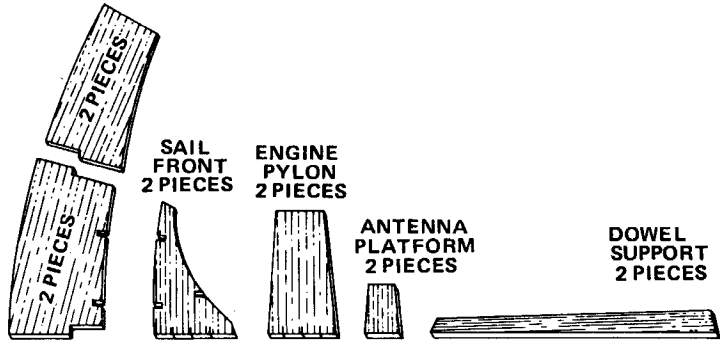

Sort and identify the parts as shown. Make sure all mating edges match on the sail halves.

3

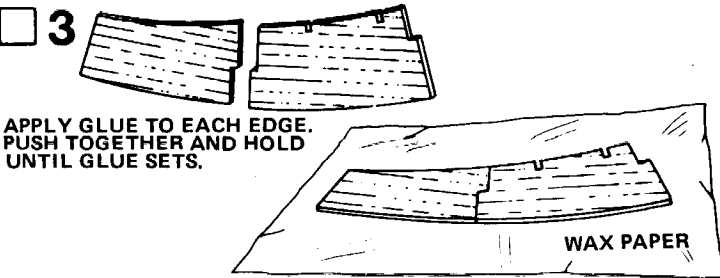

Glue the sails together as shown, making sure you match one notched and one unnotched half. Lay the sail assemblies flat on a piece of waxed paper and weight down to hold in position while the glue dries.

4

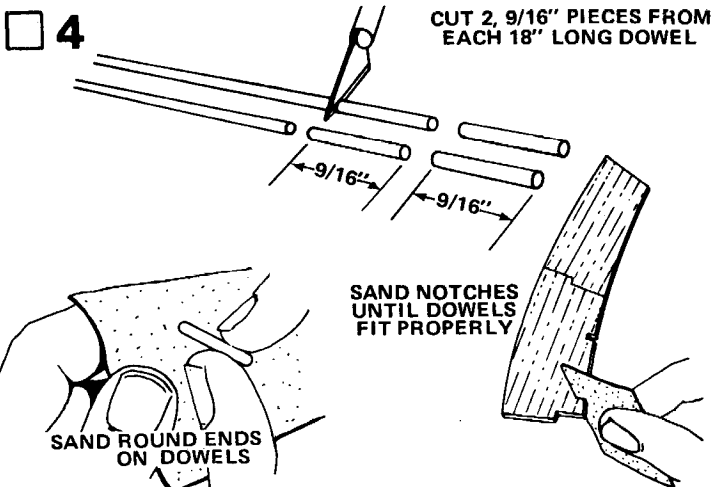

Cut two 9/16" long pieces from each of the two 18" long 1/8" wood dowels (part B). Sand round each end of the four dowel pieces. After the glue has dried on the sail, test-fit the 9/16" long

dowels in the notches in the sails and in the sail front. If dowel pieces do not fit properly, fold a piece of extra-fine sandpaper and use it to open the notches until dowel pieces fit.

5

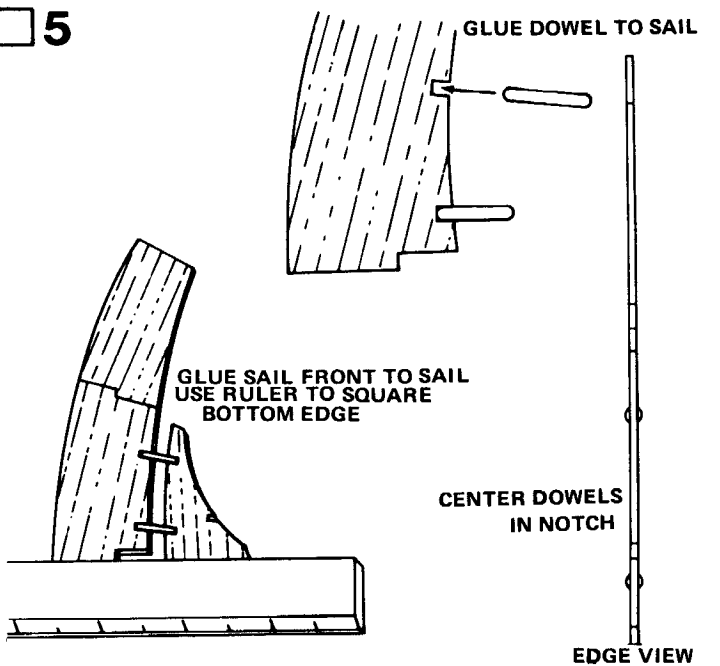

Glue dowel pieces to sail and then glue front sail part to dowels as shown. Make sure dowel pieces are centered in each of the notches. Set bottom edges of the parts against a ruler to make sure they are straight.

6

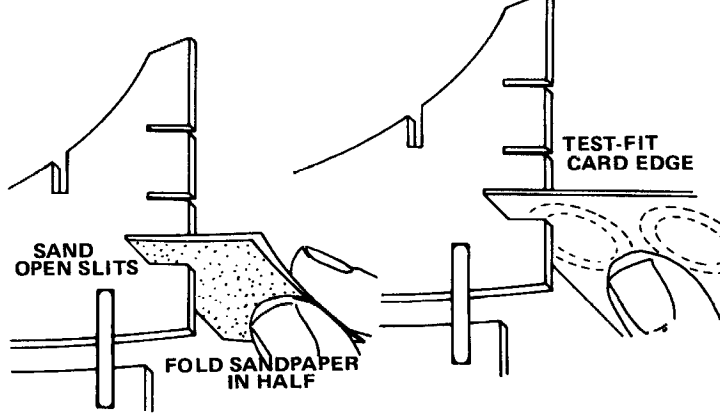
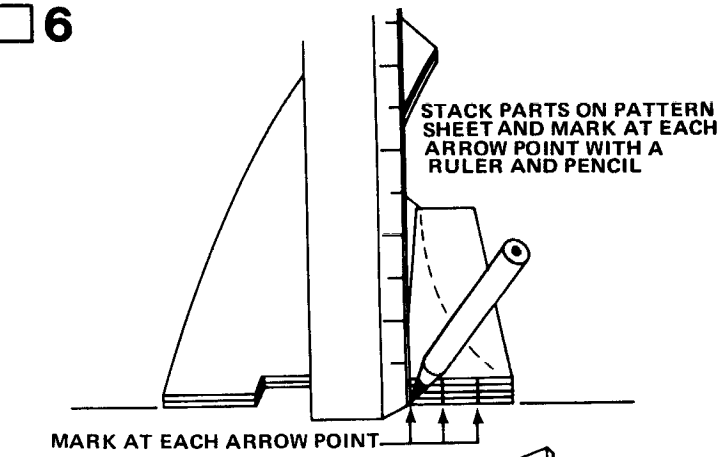

The sail fronts and engine pylons each have three slits die-cut in their root edges. Stack these four parts so the slits match. If the slits do not show up, stack the four parts on the illustration on the pattern sheet (part C) and mark the root edges at the arrow points as shown. Fold a piece of extra-fine sandpaper and use it to open the slits until the die-cut card material (part D) fits snugly in the slits.

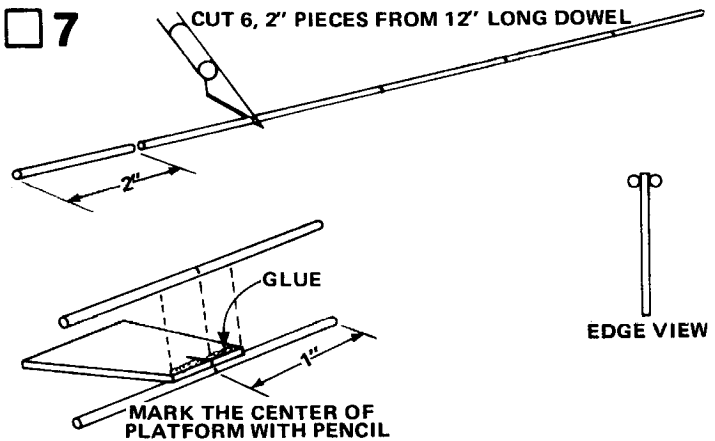

Cut the 12" long dowel (part E) into six 2" pieces. Glue two pieces to the end of each antenna platform. The 2" dowel antennas should be perfectly centered on the ends of the platforms as shown.

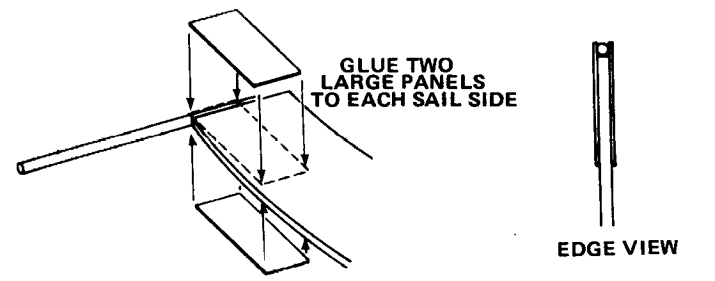
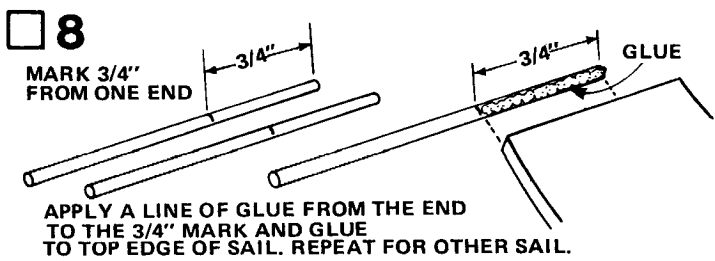

Mark the two remaining 2" dowels 3/4" from one end. Apply a line of glue along one edge of a dowel to the 3/4" mark and apply dowel to the top edge of each sail as shown. After glue sets, apply glue to the back sides of the large panels from the die-cut card and position them as shown on the sides of each sail.

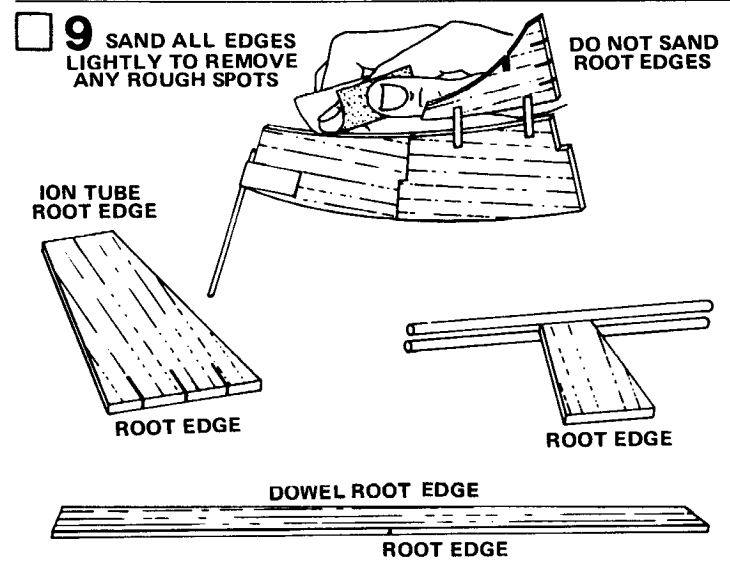

Fine-sand both sides of each wood part and all outside edges THAT ARE NOT ROOT EDGES to remove any rough spots and mismatch in glue joints.

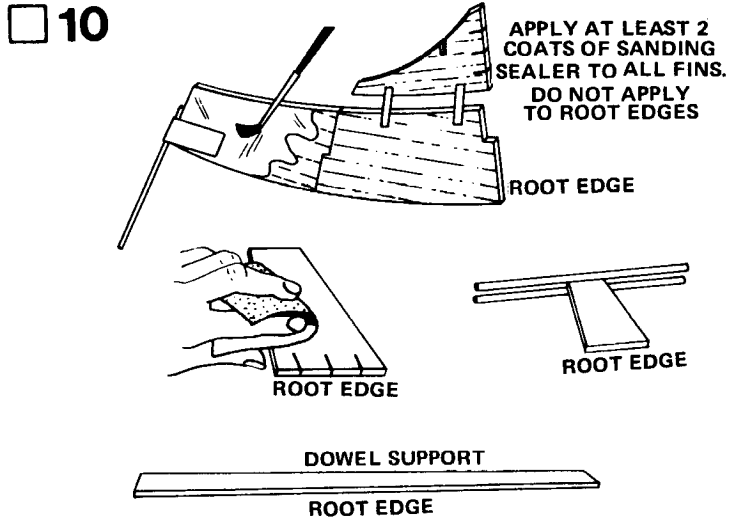

Apply a coat of sanding sealer to all surfaces of wood parts except root edges (edges that glue to tubes or dowels). Allow sealer to dry, then lightly sand parts. Repeat sealing and sanding steps a second time. Repeat until tiny grain lines in the wood are filled and everything looks and feels smooth.

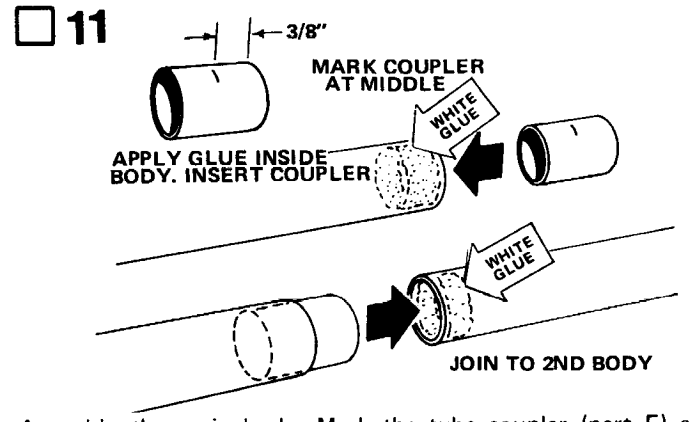

Assemble the main body. Mark the tube coupler (part F) at its middle. Smear glue around the inside of one end of an 18" body tube (part G). Insert the coupler into the glued body end so half of the coupler is in the tube. Let the glue set, then smear glue inside one end of the other 18" tube and slide glued end onto the coupler to join the tubes. Lay the assembly on a flat table top and roll gently to make sure the tubes are straight.

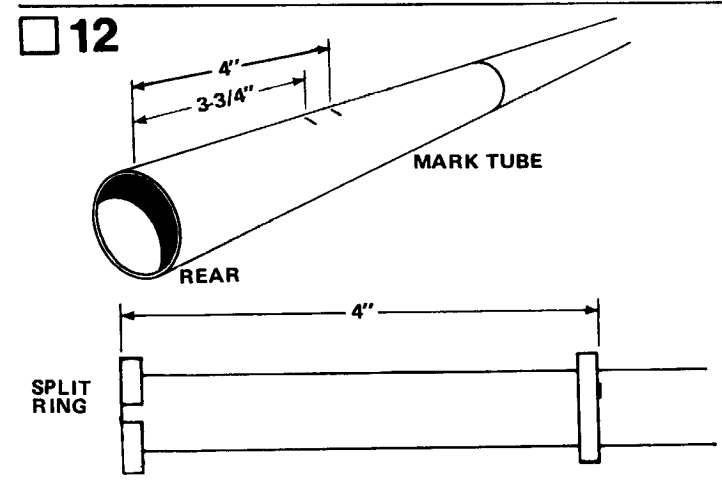

Mark the rear end of the body assembly 3-3/4" and 4" from the end. Apply a line of glue around the tube at the 3-3/4" mark and slide one of the adapter rings (part H) onto the tube until the front end of the ring is even with the 4" mark. Wipe away any excess glue immediately. Glue the split adapter ring (part I) to the tube so it is even with the rear end.

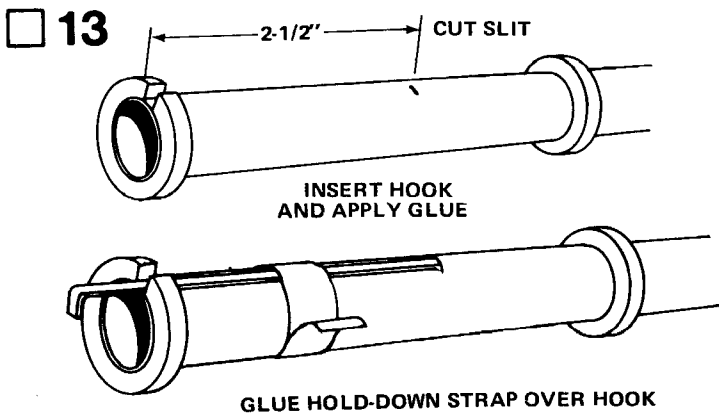

INSERT HOOK AND APPLY GLUE

GLUE HOLD-DOWN STRAP OVER HOOK

Cut a 1/8" slit in the body, directly in line with the gap in the split adapter ring, 2-1/2" from the end of the body. Cut out the hold-down strap from the pattern sheet. Insert one end of the engine hook (part J) into the slit and lay the hook along the body so the other end passes through the gap in the split ring. Smear glue over one side of the hold-down strap and wrap it around the body, centered over the hook. Apply a drop of glue over the forward end of the engine hook.

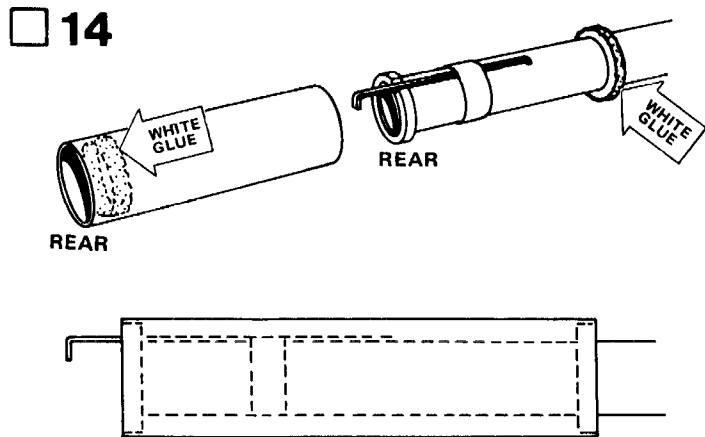

REAR

REAR

WHITE GLUE

WHITE GLUE

Apply a line of glue to the forward adapter ring and the inside of one reactor body tube (part K) as shown. Slide the reactor tube into place, matching its ends with the adapter rings. Wipe away any exposed glue.

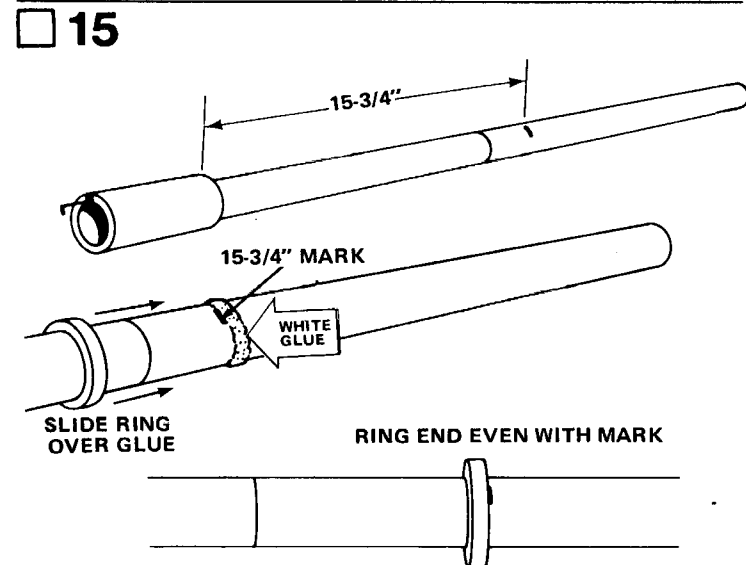

RING END EVEN WITH MARK

SLIDE RING OVER GLUE

15-3/4" MARK

15-3/4"

WHITE GLUE

Mark the main body tube 15-3/4" from the front of the reactor body tube. Slide an adapter ring down the main body past the 15-3/4" mark. Apply a line of glue around the main body at the mark and slide the adapter ring up until the rear end of the ring is even with the mark.

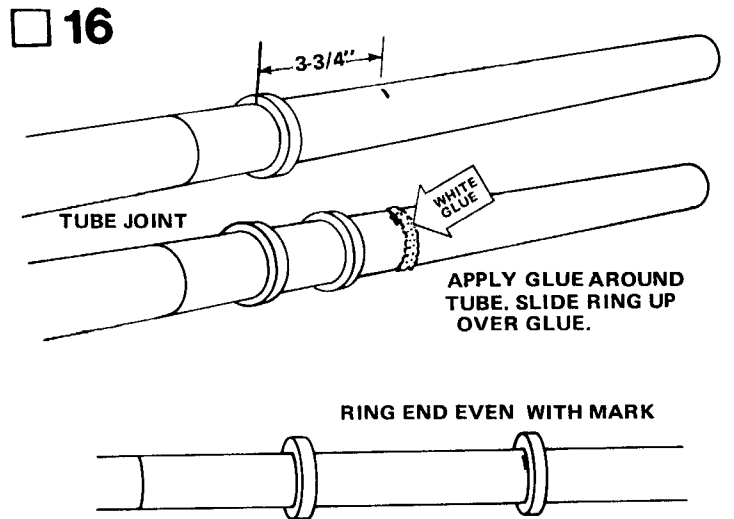

APPLY GLUE AROUND TUBE. SLIDE RING UP OVER GLUE.

RING END EVEN WITH MARK

Mark the main tube 3-3/4" from the rear end of the adapter ring. Slide another ring past the 3-3/4" mark and apply a line of glue around body tube at the mark. Slide the adapter ring up until the rear of the ring is even with the mark.

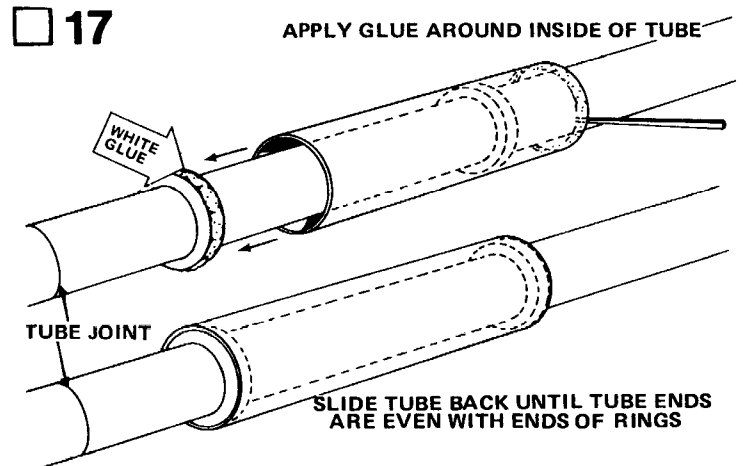

APPLY GLUE AROUND INSIDE OF TUBE

WHITE GLUE

TUBE JOINT

SLIDE TUBE BACK UNTIL TUBE ENDS ARE EVEN WITH ENDS OF RINGS

Slide the 4" long secondary body tube onto the forward ring and almost to the next adapter ring. Use a toothpick or short dowel scrap to apply a ring of glue just inside the front end of the tube. Apply glue around the outside of the second ring, then slide the tube back over the ring until the end of the tube is even with the end of the ring. Wipe away excess glue.

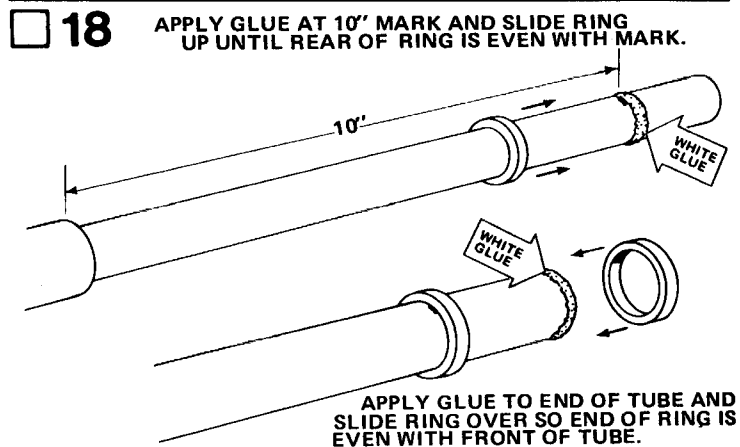

APPLY GLUE TO END OF TUBE AND SLIDE RING OVER SO END OF RING IS EVEN WITH FRONT OF TUBE.

Mark the main body tube 10" from the front of the secondary tube. Slide another ring past the 10" mark. Apply a line of glue around body tube and slide the adapter ring up until the rear of the ring is even with the mark. Apply a line of glue around the front end of the main tube and slide the remaining adapter ring over glue, so front end of ring is even with front end of tube.

□ 19

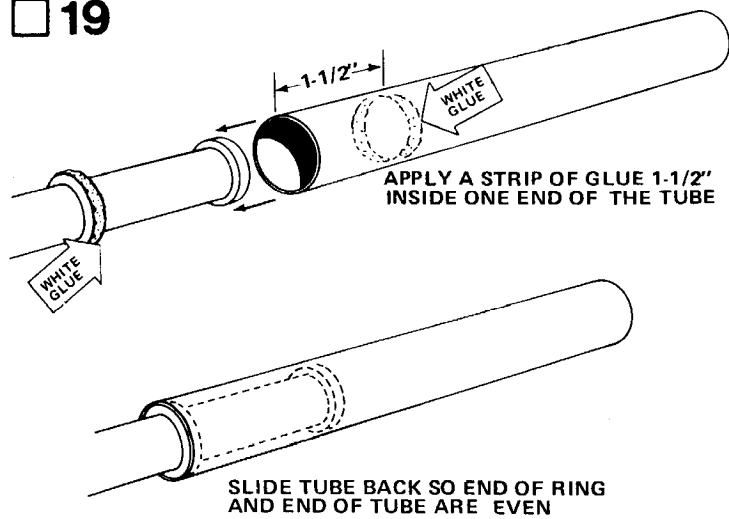

Smear a band of glue around the inside of the parachute compartment tube (part L), 1-1/2" inside one end of the tube. Apply glue around the outside of ring as shown. Slide end of the tube with glue inside, onto the rings until the end of the tube and end of the ring are even. Wipe away excess glue.

□ 20

MARK AT ARROW POINTS

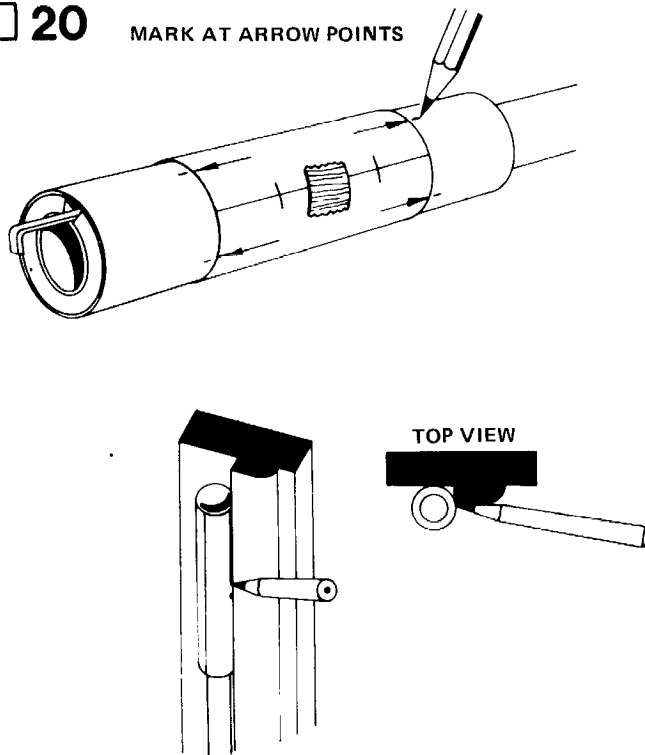

EXTEND LINES FORWARD TO THE ENTIRE LENGTH OF THE REACTOR TUBE AND SECONDARY TUBE

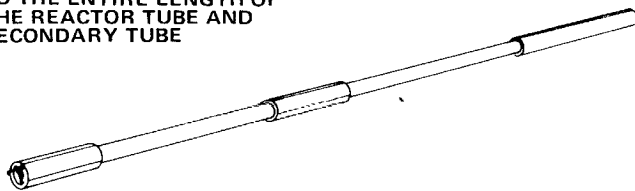

Cut out the reactor body tube marking guide from the pattern sheet. Wrap it around the reactor body and mark at each arrow point as shown. Draw straight lines connecting each mark. A door frame inside edge can be used as a guide. Extend the lines the full length of the reactor tube, and without moving the tube, draw corresponding lines the full length of the secondary tube.

□ 21

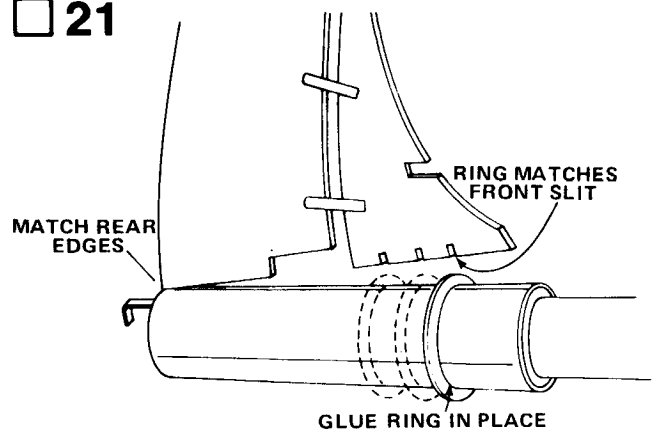

Position the front radiator ring (from the die-cut card) on the reactor body using a sail for a guide. The ring should match the front slit on the sail when the rear of the sail is even with the rear of the reactor body. Glue the ring to the body in this position. A drop or two of glue is sufficient -- do not over-glue. Use the sail to make sure the ring is correctly positioned all around the body. Slip the other two rings onto the reactor body in their approximate positions, but do not glue.

□ 22

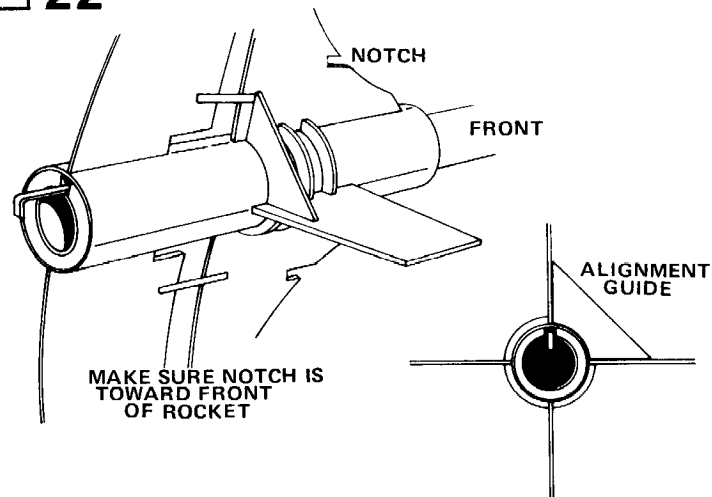

Glue the sails and engine pylons to the reactor body. Apply a line of glue to the root edge of a sail and rub it into the wood. Allow glue to set. Apply another line of glue and position the sail on the body with the radiator rings in the slits. Use the alignment guide from the die-cut card to make sure the sail projects straight out from the body. Install the remaining sail and the engine pylons this way. When the sails and pylons are in position, apply glue to the joints between rings and body tube with a toothpick. Let the assembly dry thoroughly.

□ 23

LOCATE ALIGNMENT LINE CORRESPONDING WITH ONE OF SAILS

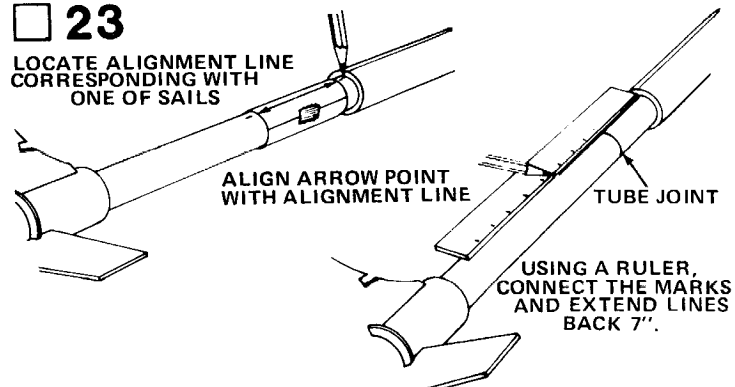

Cut out the main body tube marking guide from the pattern sheet and wrap it around the main body tube just behind the secondary

tube. Locate the alignment line on the secondary tube that is in line with a sail and align one of the arrow points on the guide with this line as shown. Mark at each arrow point as shown. Use a ruler to draw a straight connecting line between each matching pair of marks. Extend the lines back from the rear of the secondary tube about 7".

**24** GLUE DOWEL SUPPORTS TO MAIN BODY TUBE

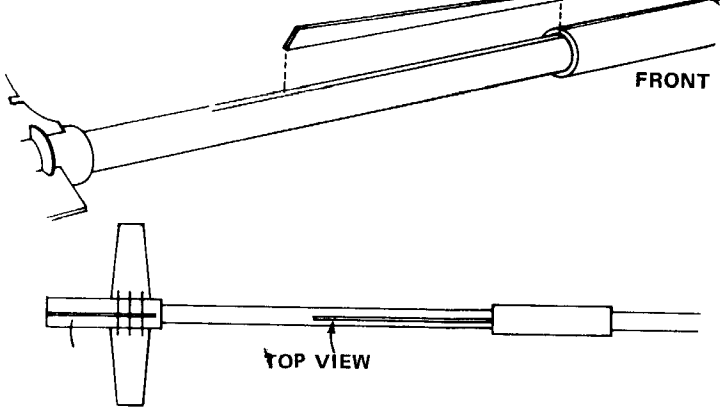

Glue the dowel supports to the main body on the lines drawn in Step 23, with the small end of the supports directly behind the secondary tube. Sight along the model from the front and adjust the supports so they are aligned with the sails.

**25** GLUE ANTENNA PLATFORMS TO SECONDARY TUBE  
EDGE OF PLATFORM IS EVEN WITH EDGE OF TUBE

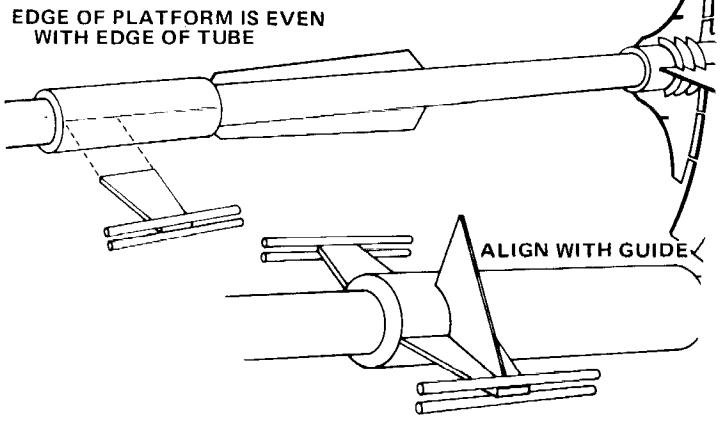

Glue the antenna platforms to the secondary body tube. The front edge of each platform should be even with the front edge of the secondary tube as shown. Use the alignment guide used in Step 22 to be sure the antenna platforms project straight out from the tube.

**26**

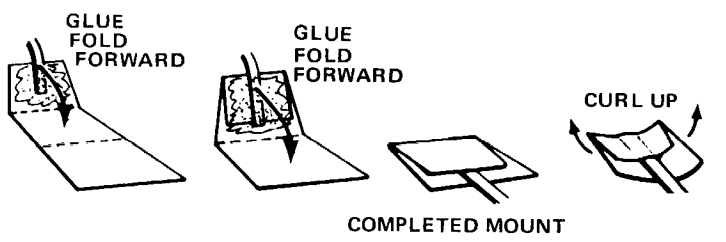

Cut out the shock cord mount (part N). Fold on dotted lines, then unfold and apply glue to Section 1. Lay the end of the shock cord (part M) in the glue. Fold over and apply glue to the back of Section 1 and the exposed portion of Section 2. Fold again to complete the mount. Curl the edges of the mount up so it will match the contour of the body tube and hold with your fingers until the glue sets.

**27**

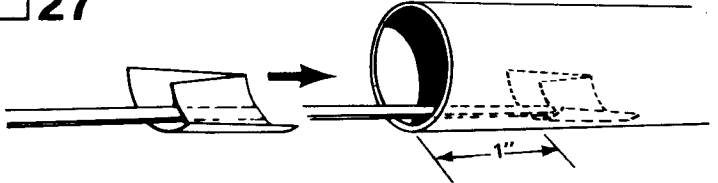

Use a stick or dowel to apply a generous amount of glue inside the parachute compartment tube 1" from the front edge to allow clearance for the nose cone to socket into place. Slide the shock cord mount into the tube and press it into the glue. To ensure a good bond, use a stick or your finger to smear a film of glue over the mount and surrounding area in the tube.

**28**

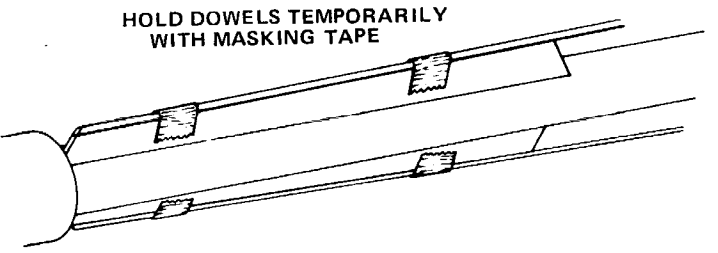
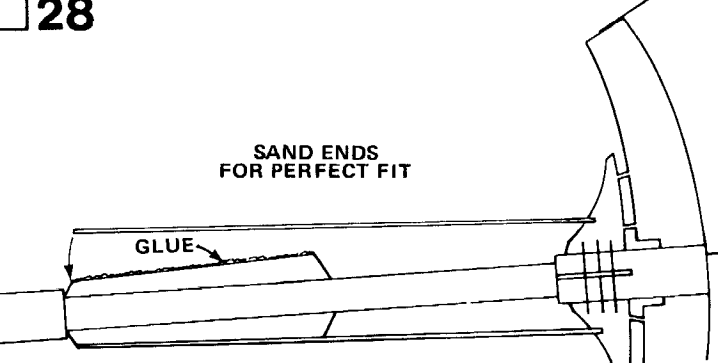

Test-fit the 1/8" diameter dowels used in Step 4 between the sails and the dowel supports. Trim the dowels to the correct length. For best results, cut the dowels 1/32" to 1/26" longer than needed and then match to the sail and supports by sanding the ends. Glue the dowels to the sails and supports. Temporarily tape each dowel in position with a short piece of masking tape until glue sets. DO NOT wait until the glue is completely dry or tape will stick.

**29**

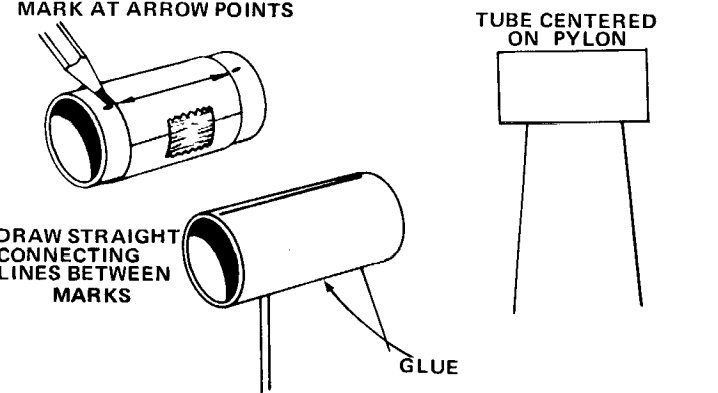

Cut out the ion tube marking guide from the pattern sheet. Wrap it around an ion tube (part O) and mark at each arrow point. Repeat with the other ion tube. Draw straight connecting lines between marks. Apply glue to end of the pylon and center the tube on the pylon and the alignment lines.

□ 30

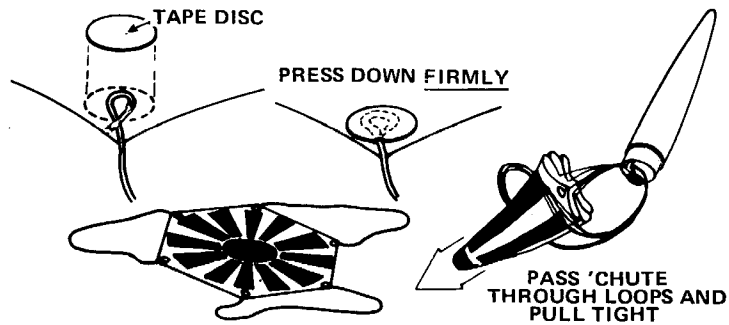

Cut out the parachute (part P) on its edge lines. Cut the shroud line (part Q) into three equal lengths. Form a small loop in one end of a shroud line and attach to a corner of the 'chute with a tape disc (part R). Press the tape disc down very firmly over the line. Attach the opposite end of the shroud line to an adjacent corner of the 'chute. Attach the remaining shroud lines in the same manner. Pass the center of the shroud line loops through the "eye" of the nose cone (part S). Pass 'chute through loops and draw the lines tight.

□ 31

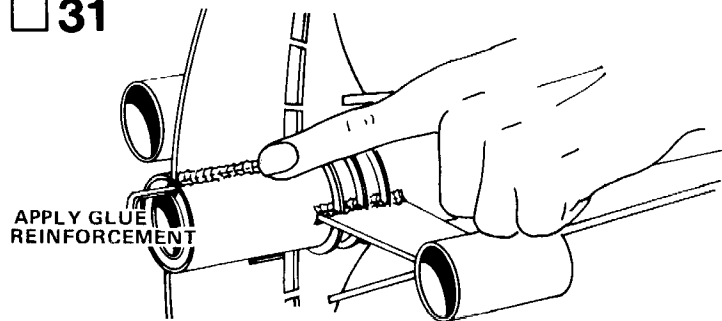

When all the glue joints have dried, apply a glue reinforcement to each sail, pylon, support, and body tube joint. Holding the model horizontally, apply a line of glue to the joint and smooth it out with your finger. Support the rocket horizontally while the glue dries.

□ 32

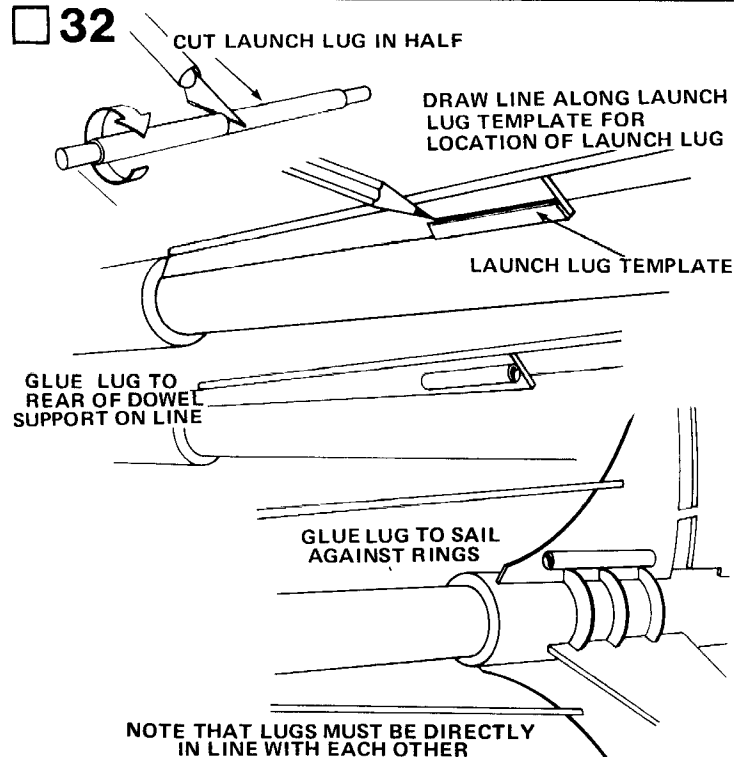

**NOTE THAT LUGS MUST BE DIRECTLY IN LINE WITH EACH OTHER**

Cut out the launch lug location template from the pattern sheet. Mark the lug location on the dowel support as shown. Cut the

launch lug (part T) into two equal parts. Glue one of the launch lug halves to the dowel support on the mark. Glue the other half lug to the sail -- against the radiator rings and directly in line with the first lug.

□ 33

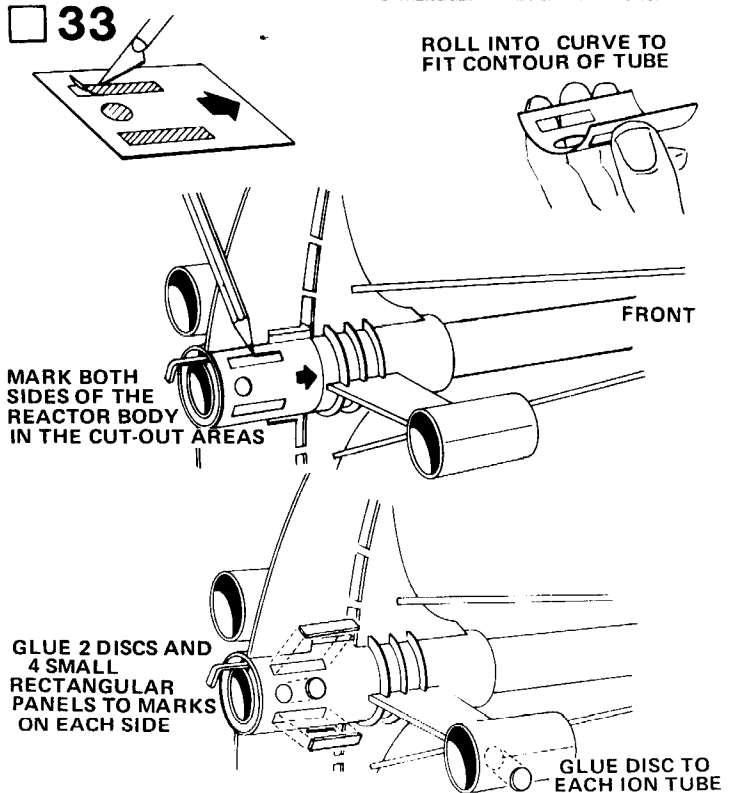

Cut out the shaded areas from the reactor detail template. Pre-form the template, and mark both sides of the reactor body in the cut-out areas. Glue two discs and four small rectangular panels to the locations marked. Glue two more discs centered on the alignment line on the ion tubes near the rear edge of the tube. Glue the remaining two discs to the secondary tube top and bottom alignment lines near the front edge of the tube.

□ 34

**TIE FREE END OF SHOCK CORD TO NOSE CONE**

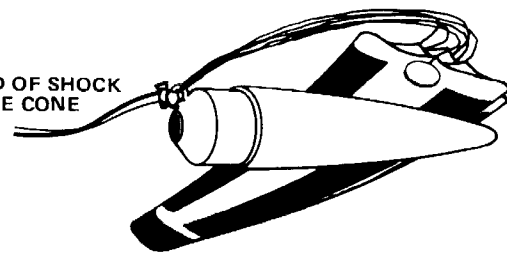

**PACK 'CHUTE AND SHOCK CORD INTO COMPARTMENT TUBE**

Tie the free end of the shock cord to the "eye" on the nose cone. Fold the 'chute, pack 'chute and shock cord into parachute compartment tube, and socket nose cone in place.

□ 35

Before painting, clean the rocket with a slightly damp cloth to remove oily fingerprints. The entire rocket is painted chromate green. We recommend Pactra Chromate Green spray enamel. Do not paint the model with lacquer paint. It will mar the finish of the plastic nose cone. Spray the model with several light coats of paint to avoid "runs". Paint inside of ion tubes with a brush and a bottle of bright red enamel paint. Allow the rocket to dry for 2 to 4 hours before applying decals.



36

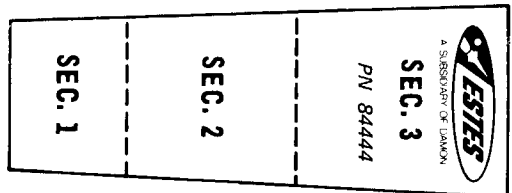
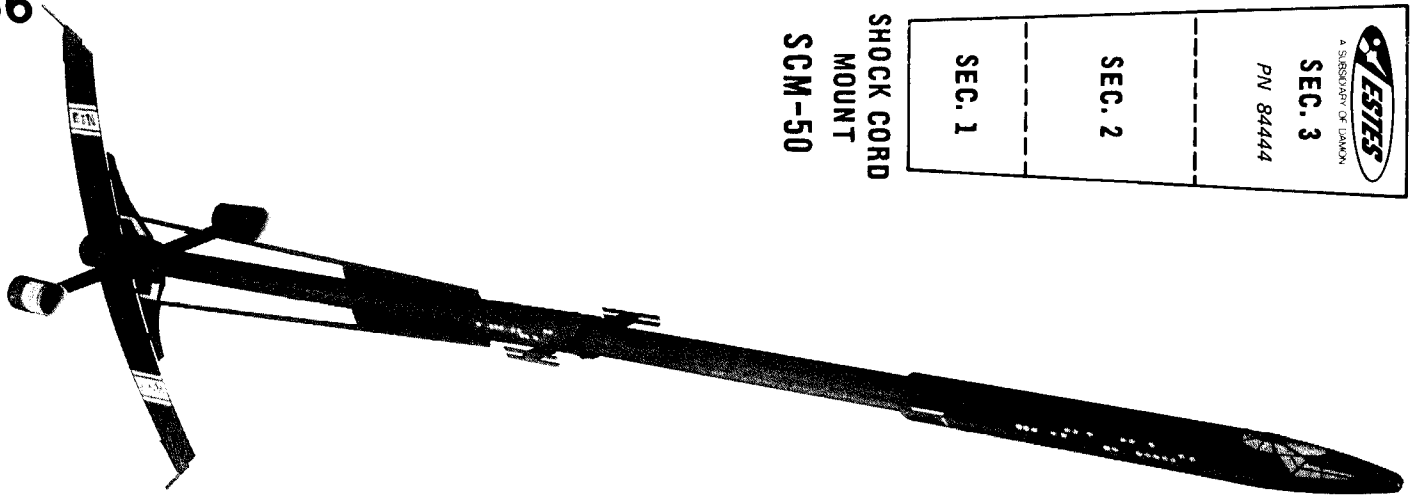

Apply decals (part U) in positions shown in the photograph above and on the color panel. To apply decals cut only one decal at a time from the sheet. Submerge decal in water for 15 to 20 seconds (until decal slides on backing sheet). Gently slide decal from backing sheet and onto the model. Move decal into exact position and carefully blot away excess water with a soft cloth. If the decal "sticks"

before you have it in position, apply water over the decal with a brush. This will permit the decal to be moved. Smooth out all wrinkles and air bubbles before the decal dries. We recommend that the completed model be sprayed with either Testor's "DullCote" or "Gloss Cote". This will protect the model's finish.

## LAUNCHING COMPONENTS

- To launch your rocket you will need the following items:
- An Estes model rocket launch system
- Parachute recovery wadding (Estes Cat. No. 2274)
- Recommended Engines: B6-2, B6-4, B8-5, or C6-5.
- Use a B6-4 engine for your first flight.

Be sure to follow the HIAA-NAR\* Model Rocket Safety Code when carrying out your model rocket activities.

\*HIAA -- Hobby Industry Association of America  
 NAR -- National Association of Rocketry

**T-10** Insert engine into rocket engine mount. Engine hook must latch securely over end of the engine.

**T-9** Disarm the launch panel -- REMOVE SAFETY KEY!

## T-8

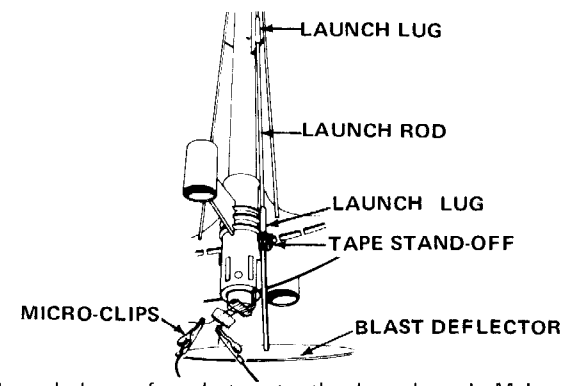

Slide the launch lugs of rocket onto the launch rod. Make sure rocket slides freely on the launch rod. If the launch pad you are using does not have a rocket stand-off, place a piece of masking tape on rod as shown to keep rocket 1" above the deflector plate. Clean micro-clips, attach them to the igniter wires as close to engine nozzle as possible. Arrange the clips so they do not touch each other or the metal blast deflector.

**T-7** Clear the launch area, alert recovery crew and trackers. Check for low flying aircraft and unauthorized persons in the recovery area.

**T-6** Arm the launch panel -- INSERT SAFETY KEY!

**-5-4-3-2-1-LAUNCH!!**

Repeat Countdown Checklist for each flight.

## MISFIRE PROCEDURE

Occasionally the igniter will heat and burn into two pieces without igniting the engine. This is almost always caused by a failure to install it correctly. REMOVE SAFETY KEY from launch panel, remove the model, clean the igniter residue from the engine nozzle, and install a new igniter. Repeat the Countdown Checklist.

## COUNTDOWN CHECKLIST

**T-13** Pack 4 or 5 squares of loosely crumpled recovery wadding into the body tube.

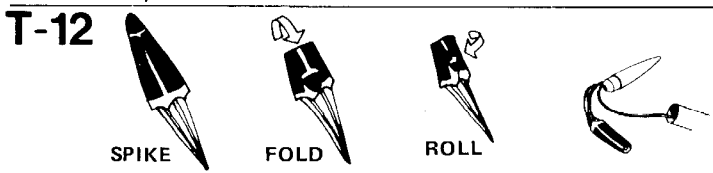

Hold the parachute at its center and pass the other hand down it to form a "spike" shape. Fold this spike in half. Roll parachute into tube shape to fit easily into body. Pack chute into the tube on top of the wadding. Pack the shroud lines and shock cord in on top of the parachute and slide the nose cone into place.

**NOTE: DO NOT** pack parachute until you are actually ready to launch. For maximum parachute reliability, lightly dust the chute with ordinary talcum powder before each flight, especially in cold weather.

**NOTE:** Nose cone should separate easily from rocket body tube, but should not be extremely loose. If fit is too tight, sand inside of body tube and shoulder of nose cone with fine sandpaper. If fit is too loose, add a wrapping of transparent tape or masking tape to the shoulder of the nose cone.

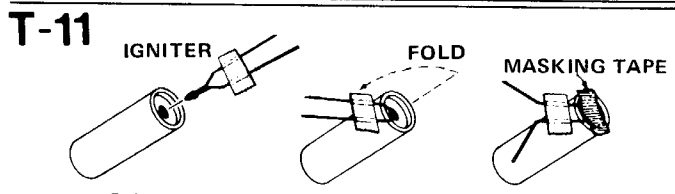

Select an engine and install an igniter as directed in the engine instructions. Use a B6-4 engine for your first flight.

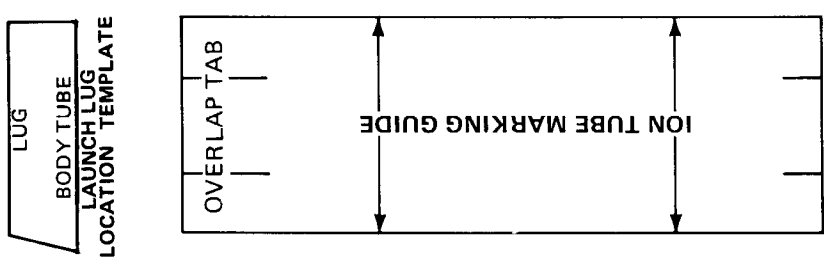
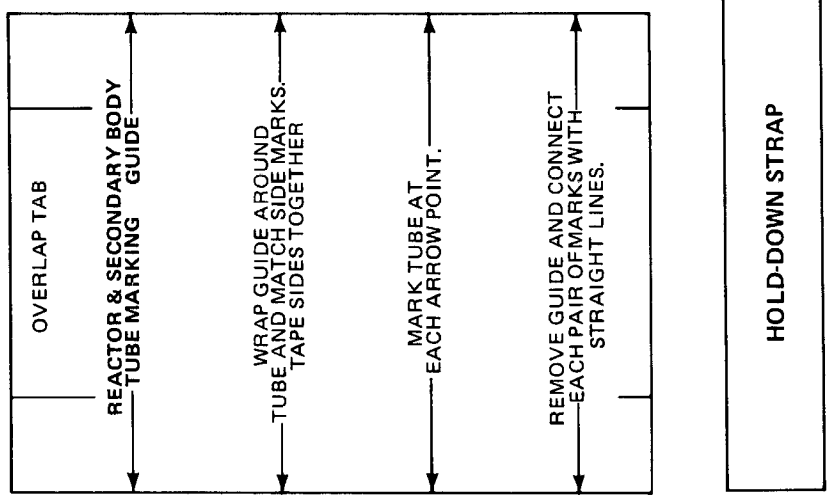
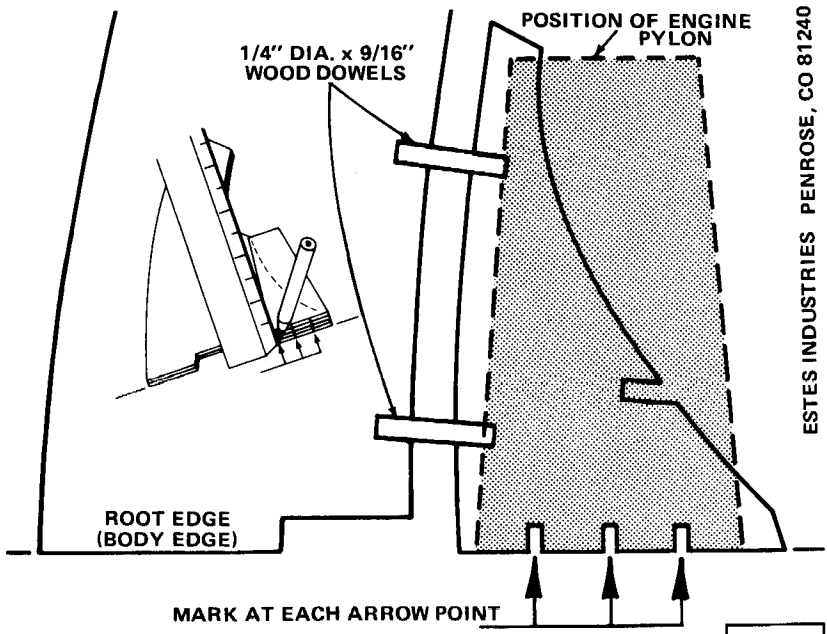

ALIEN EXPLORER PATTERN SHEET PN 83367

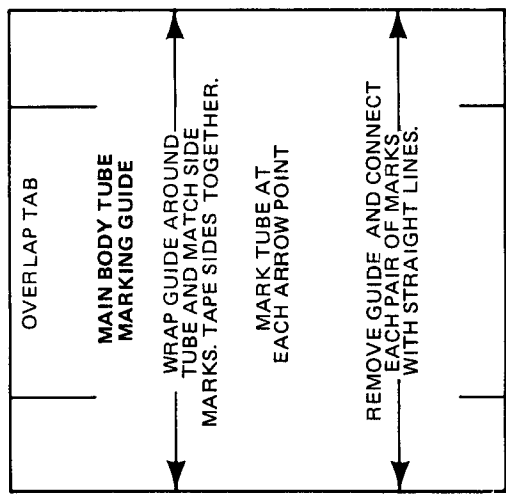
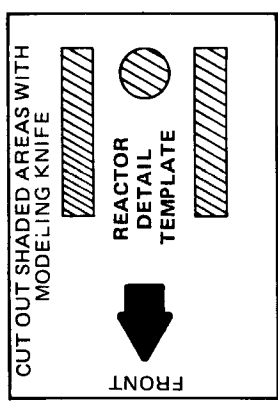

11/10 8 3 0/11

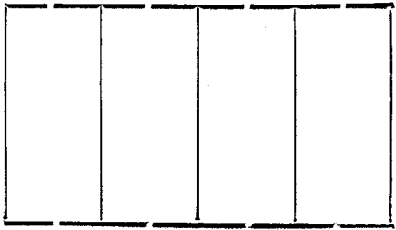
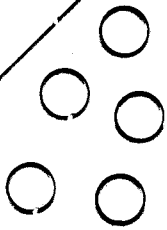
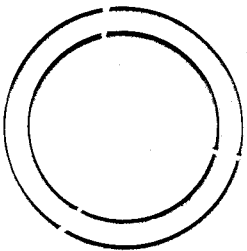
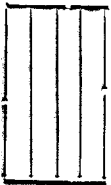
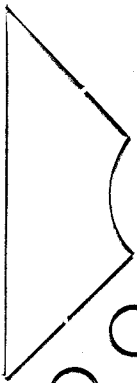
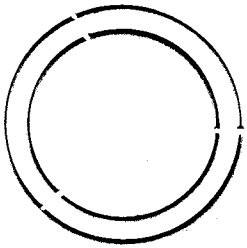
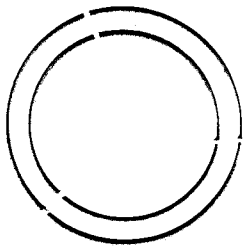

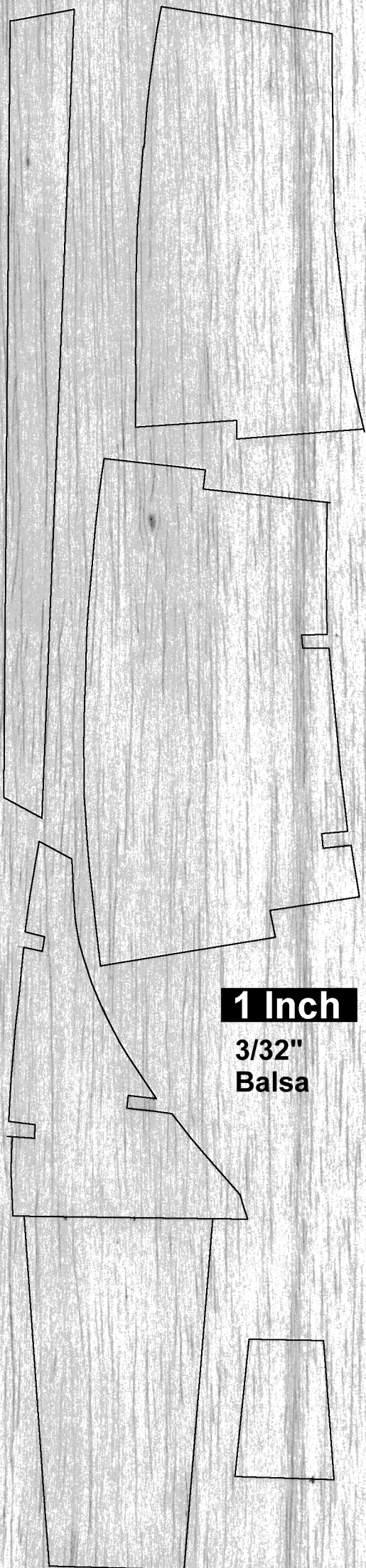

**1 Inch**

**3/32"  
Balsa**



# alien explorer

## FLYING MODEL ROCKET

SKILL LEVEL 3

1-Beginner 2-Intermediate 3-Craftsman  
4-Advanced 5-Expert

- Incredible Alien Starship
- Dramatic Display Model
- Really Spectacular Lift-Offs
- Die-Cut Balsa Fins
- Quick-Release Engine Mount
- Big 18" Parachute Recovery
- Very Exotic Kit Decals

Flights  
Over  
600  
Feet!

Length: 40" (101.6 cm)  
Dia: .370" (9.4 mm)  
Wt: 2.43 oz. (68.8 g)  
Engines: BB-2 BB-4 (1st Flt.)  
BB-6 CB-1

This is a hobby kit requiring assembly.  
Recommended for ages 10 to adult.  
Engines, launch system, glue and finishing  
supplies are not included. Adult supervision  
is suggested for those under 12 years of age  
when flying model rockets.



#1372



ESTES INDUSTRIES  
PERU, IN 47434 USA