

U.S.S. HYPERION

SKILL LEVEL 3 - Recommended for Craftsman Rocketeers.

BEFORE YOU START

Read each step and study the accompanying drawings before doing any of the work called for in that step. Make sure you have all parts and materials. Check off each step as you complete it. Always test-fit parts together before applying glue. It will sometimes be necessary to sand edges of rings, tubes, etc. to obtain a proper fit. If you are in doubt about the relative size or location of some parts, refer back to this exploded view drawing for clarification. Adequate glue joints are very important for a flying model rocket. Follow the instructions carefully in this regard.

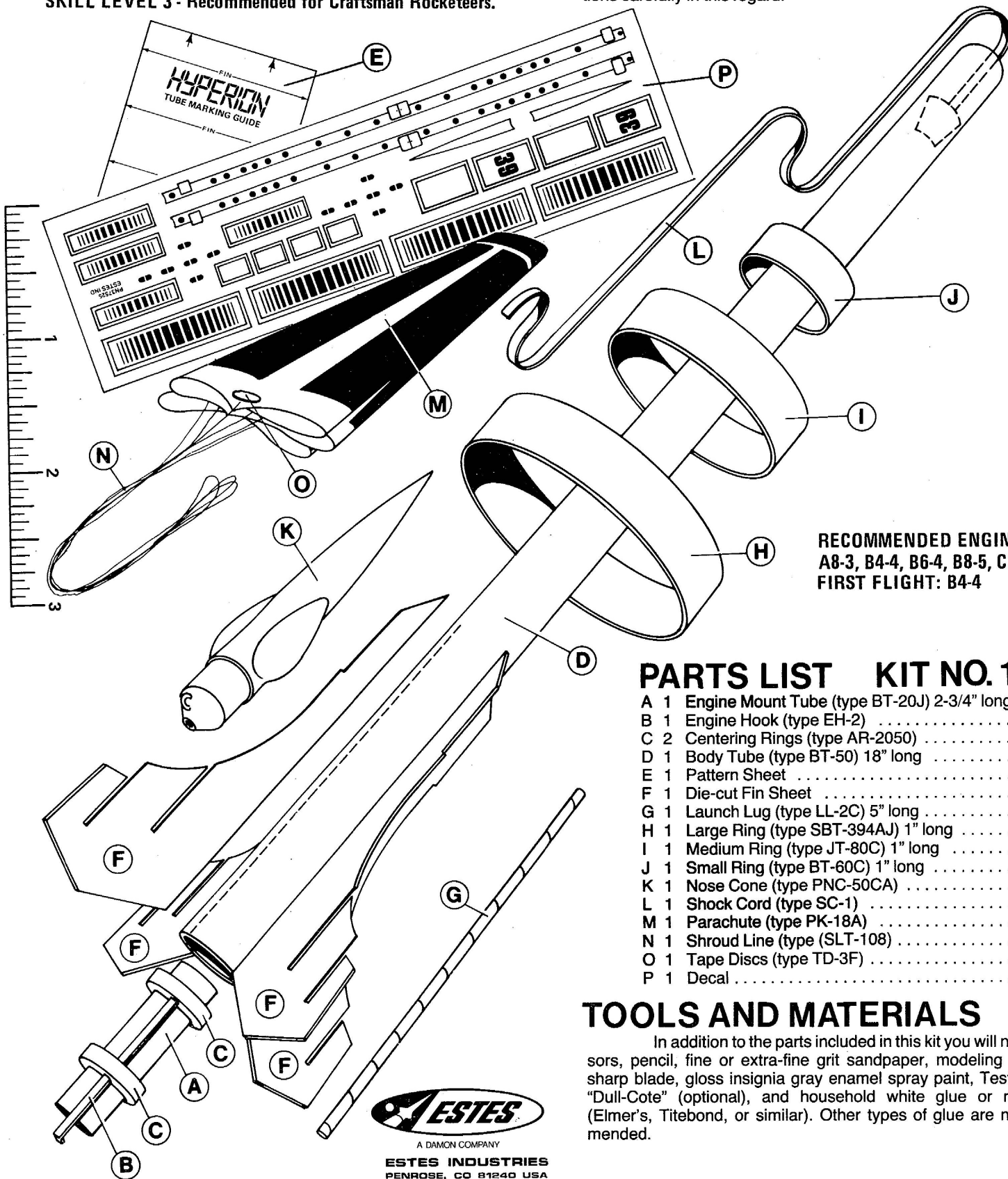

RECOMMENDED ENGINES:
A8-3, B4-4, B6-4, B8-5, C6-5
FIRST FLIGHT: B4-4

PARTS LIST KIT NO. 1383

| | | | |
|---|---|---|-------|
| A | 1 | Engine Mount Tube (type BT-20J) 2-3/4" long | 30326 |
| B | 1 | Engine Hook (type EH-2) | 35025 |
| C | 2 | Centering Rings (type AR-2050) | 30164 |
| D | 1 | Body Tube (type BT-50) 18" long | 30352 |
| E | 1 | Pattern Sheet | 83418 |
| F | 1 | Die-cut Fin Sheet | 32463 |
| G | 1 | Launch Lug (type LL-2C) 5" long | 38180 |
| H | 1 | Large Ring (type SBT-394AJ) 1" long | 30449 |
| I | 1 | Medium Ring (type JT-80C) 1" long | 30274 |
| J | 1 | Small Ring (type BT-60C) 1" long | 30405 |
| K | 1 | Nose Cone (type PNC-50CA) | 71005 |
| L | 1 | Shock Cord (type SC-1) | 85730 |
| M | 1 | Parachute (type PK-18A) | 85566 |
| N | 1 | Shroud Line (type SLT-108) | 38239 |
| O | 1 | Tape Discs (type TD-3F) | 38406 |
| P | 1 | Decal | 37525 |

TOOLS AND MATERIALS

In addition to the parts included in this kit you will need: Scissors, pencil, fine or extra-fine grit sandpaper, modeling knife with sharp blade, gloss insignia gray enamel spray paint, Testors spray "Dull-Cote" (optional), and household white glue or resin glue (Elmer's, Titebond, or similar). Other types of glue are not recommended.



A DAMON COMPANY

ESTES INDUSTRIES
PENROSE, CO 81240 USA

ASSEMBLY INSTRUCTIONS

1

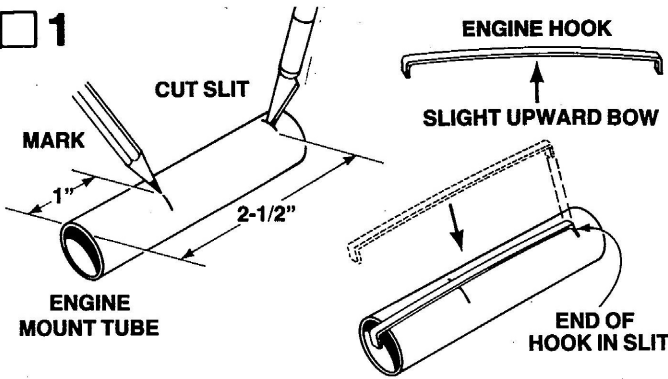

Mark the engine mount tube (part A) at 1" and 2-1/2" from one end. Cut a 1/8" long slit at the 2-1/2" mark. Gently bend the engine hook (part B) so that it bows upward very slightly in the middle. (Study the drawing.—Don't bend the wrong way.) Insert one end of the engine hook into the slit in the tube.

2

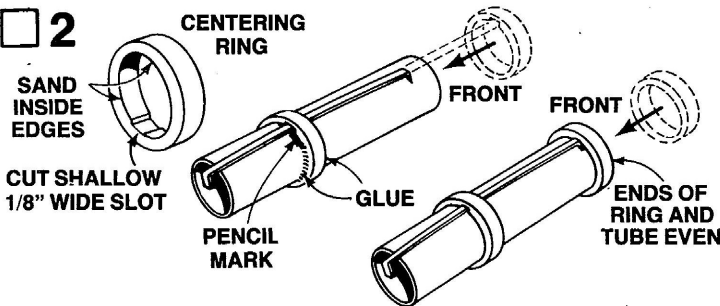

Sand the inside edges of the two centering rings (part C) to remove burrs. The rings should slide easily onto the engine mount tube. Cut a very shallow 1/8" wide slot inside one centering ring so it will fit over the engine hook. Slip the ring onto the front end of the engine mount tube and slide it down to the 1" mark. Make sure the engine hook runs straight down the tube, then apply glue to both sides of this ring. Apply glue around the front end of the engine mount tube and slide the remaining centering ring into place (front of ring even with the end of the tube).

3



The engine mount unit will be pushed into place so that the rear of the engine mount unit (end with engine hook projecting) extends 1/4" from the end of the body tube (part D). Mark the engine mount 1/4" from the rear of the tube. Test fit the engine mount into the body tube. Sand the inside edge of the body tube and the centering rings, if necessary, to obtain a good fit. Use a stick to apply a generous bead of glue around the inside of the body tube about 1-3/4" from the end. Making sure the engine hook extends to the rear, slide the engine mount into the body tube until the 1/4" mark on the mount is even with the rear of the body tube. Do not pause or the glue may "lock" with the mount in the wrong position.

4



Cut out the tube marking guide from the pattern sheet (part E) and wrap it around the rear of the body tube. Place the tube marking guide so that the engine hook will not line up with a fin placement line (arrow point). Mark the body tube at each of the arrow points. Remove the marking guide. Using a door frame as a guide, draw lines connecting each pair of marks. Extend the lines about 6" forward along the body tube.

5

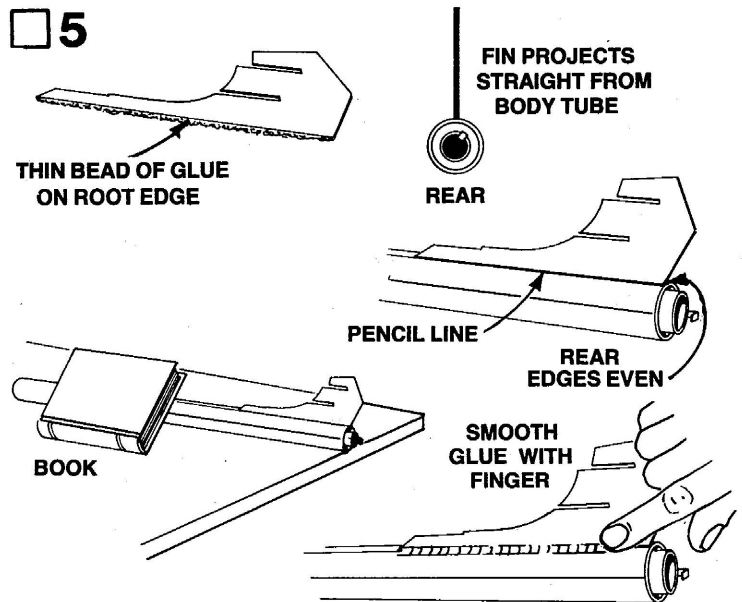

Use a knife to free the fins from the die-cut sheet (part F). Do not try to punch the fins from the sheet or you may tear them. Apply a thin bead of glue to the root edge of one fin. Place the fin on the body tube, just to the right of a pencil line and with the rear of the fin exactly even with the rear of the body tube. Make sure the fin projects straight away from the body tube. Set the assembly on a table with the fin pointing straight up. Weight the front of the body tube with a book so it will not roll. Allow glue to dry for 20 minutes, then run a bead of glue along both sides of the fin. Smooth the glue with your finger and remove any excess glue. Check again to make sure the fin projects straight from the body. Set the unit on the table (fin pointing straight up), weight with book and allow glue to dry completely before proceeding with next step.

6

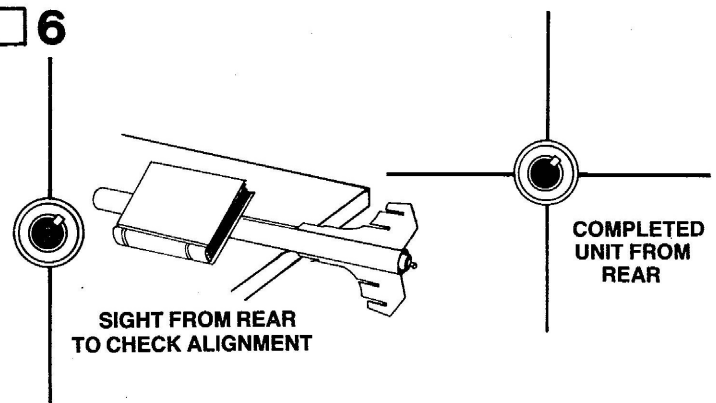

Attach a second fin to the opposite side of the body using the same procedure as in the previous step. As before, the fin is positioned just to the right of the pencil line. Sight from the rear of the unit to make sure the fins are straight up and down. Support the assembly with the fins extending off the edge of the table. As before, apply a good glue reinforcement and allow to dry completely. The remaining fins are attached in the same manner. In each instance, the fin is positioned just to the right of the pencil mark.

7

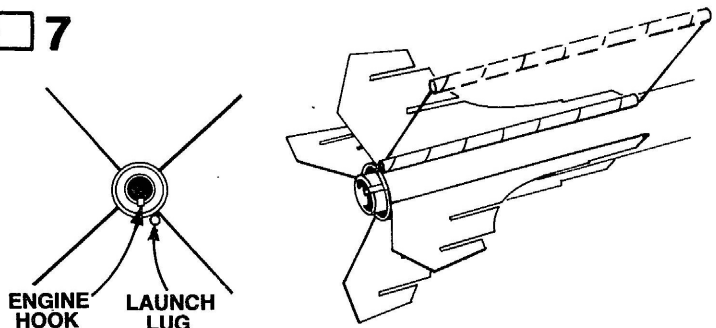

Glue the launch lug (part G) to the body tube in the position shown. Note the position of the launch lug in relation to the engine hook.

□ 8

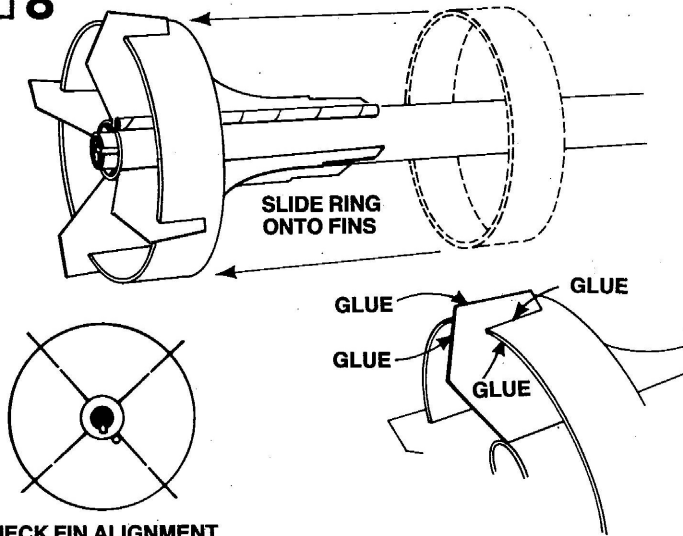

CHECK FIN ALIGNMENT

Slide the largest body tube ring (part H) onto the rocket from the front. Fit the ring into the outside set of slots in the fins. Check the fin alignment once again. If any fins are crooked, straighten them before gluing the ring in place. Use a small stick to apply a bead of glue to all sides of the joints where the ring fits into the fin slots. Allow glue to dry. Make sure any gaps between the ring and slots are filled in with glue. Apply a second bead of glue, where necessary, to fill any gaps.

□ 9

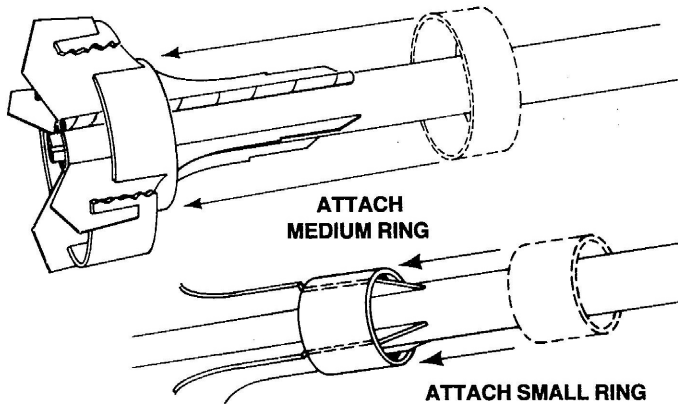

Slide the medium body tube ring (part I) onto the rocket. This ring fits into the inner set of slots in the fins. Glue this ring in place in the same manner as used for the large ring. The small ring (part J) is attached next. This ring fits around the forward portion of the fins. Use the stick to apply a bead of glue to the inside of the ring where it touches the fins.

□ 10

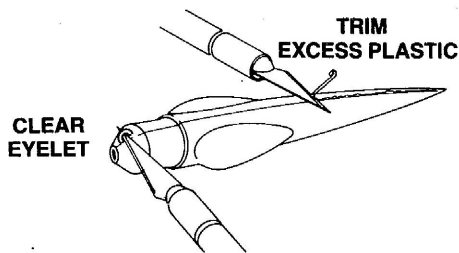

Trim or sand any excess plastic from around the sides of the nose cone (part K). Use a sharp knife to remove any excess plastic from the inside of the molded eyelet at the rear of the nose cone. Wash the nose cone with lukewarm soapy water, rinse well, and dry.

NOTE: Nose cone should separate easily from rocket body tube, but should not be extremely loose. If fit is too tight, sand inside of body tube and shoulder of nose cone with fine sandpaper. If fit is too loose, add a wrapping of cellophane tape to the shoulder of the nose cone.

□ 11

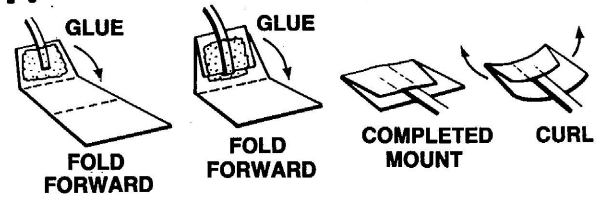

Cut out the shock cord mount from the pattern sheet. Fold on dotted lines, then unfold and apply glue to Section 1. Lay the end of the shock cord (part L) into the glue. Fold over and apply glue to the back of Section 1 and the exposed portion of Section 2. Fold again to complete mount. Curl the edges of the mount up so it will match the contour of the body tube and hold with your fingers until the glue sets.

□ 12 SET BACK TO ALLOW FOR NOSE CONE

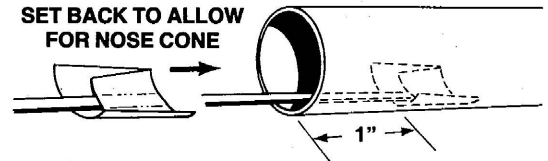

Use a finger or stick to apply glue to the inside of the front of the body tube, 1" to 2" from the front of the tube. Press the shock cord mount firmly into position in glue far enough from the front edge of the tube to allow clearance for the nose cone to fit into place. To insure a good bond use a stick or your finger to smear a film of glue over the mount and surrounding area in the body tube.

□ 13

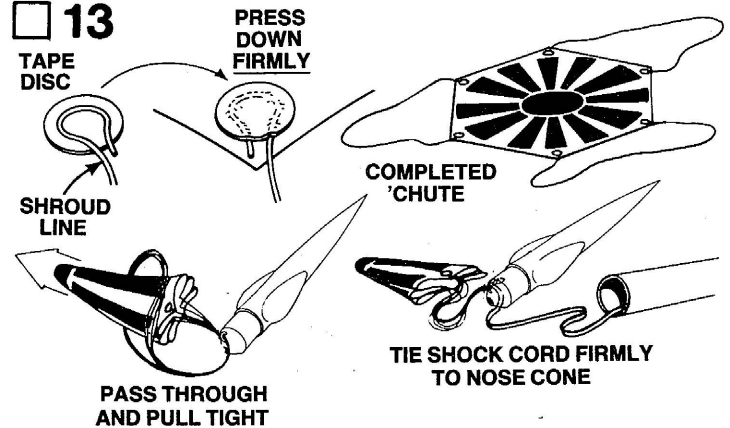

Cut out the parachute (part M) on its edge lines. Cut three equal lengths of shroud line (part N). Attach line ends to the top of the parachute with tape discs (part O) as shown. Form a small loop in the end of a shroud line. Holding loop, gently center loop inside tape disc on the sticky side. Then carefully press tape disc onto its proper place on the top of the parachute. Firmly press the tape disc into place until both tape disc and parachute material are molded around the shroud line loop. Repeat for other shroud line ends and tape discs. Pass the shroud line loops through the loop on the nose cone. Pass the parachute through the loop ends and pull the lines tight against the nose cone. Tie the free end of the shock cord firmly to the nose cone loop. A square knot or strong double knot should be used. Pack chute and shock cord into body and socket nose cone in place. (See Step T-12 on next page.)

PAINTING AND DETAILING

□ 14

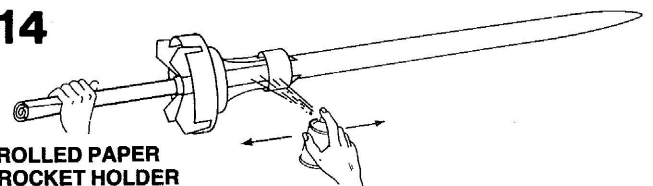

Paint the entire model insignia gray. Follow instructions on the spray can for best results. We recommend spray enamel. Do not paint the model with lacquer paint. Shake can before spraying. Hold the can straight up and spray in long, smooth "strokes". Spray the model with several light, dry mist coats of paint to avoid "runs". Shake can periodically. Be sure paint is completely dry before applying decals.

DECAL PLACEMENT

15

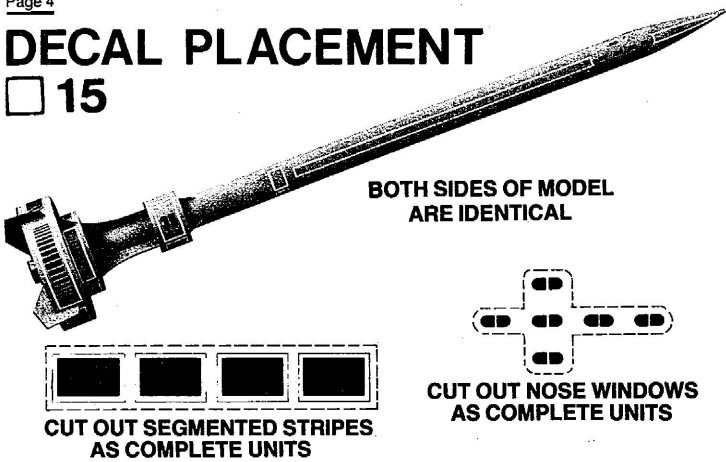

When all paint is dry, apply the decals (part P) in the positions shown. (A) Cut only one decal at a time from sheet. (B) Submerge decal in lukewarm water until decal slides on backing paper (usually 15 to 30 seconds). (C) Gently slide decal from backing paper onto model. (D) Move decal into exact position and carefully blot away excess water with a soft cloth. (E) If the decal "sticks" before you have it in position, apply water over the decal with a brush. This will permit the decal to be moved. (F) Smooth out all wrinkles and air bubbles before the decal dries. Refer to the photograph for decal positions. Two sets of control room windows fit on the bulbous shapes on both sides of the nose cone. Be careful when cutting these out so that you do not accidentally cut away any of the windows. There are two stripes that fit on the small ring and on the body tube. These stripes are in 4 segments with small clear areas between. Cut the stripes out and apply as complete units. The remainder of the decals are applied individually. We recommend that the completed model be sprayed with Testor's "Dull-Cote". This is a clear flat spray paint that kills the decal shine and protects the model's finish. The "Dull-Cote" also makes the decals stand out better on the gray rocket.

LAUNCHING COMPONENTS

- To launch your rocket you will need the following items:
- An Estes model rocket launching system
 - Flameproof recovery wadding (Estes Cat. No. 2274)
 - Estes A8-3, B4-4, B6-4, B8-5, or C6-5 model rocket engines. Use a B4-4 engine for your first flight.

Be sure to follow the HIAA-NAR* Model Rocket Safety Code when carrying out your model rocket activities.
 *HIAA—Hobby Industry of America
 *NAR—National Association of Rocketry

COUNTDOWN CHECKLIST

T-13

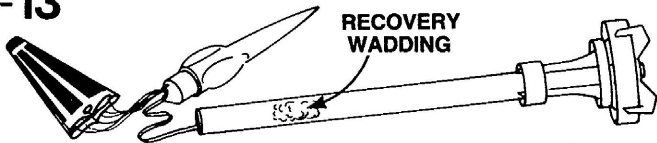

Pack 3 or 4 squares of loosely crumpled recovery wadding into the body tube. Usually this will fill the body tube for a distance equal to about 1-1/2 times its diameter.

T-12

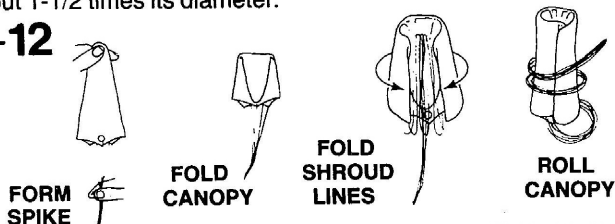

Hold the parachute at its center and pass the other hand down it to form a "spike" shape. Fold this spike in half. Fold shroud lines back along parachute and then back down to lower edge of parachute to re-

duce length of shroud line "left over". Roll parachute into tube shape to fit easily into body. Any remaining shroud line should be loosely wrapped around parachute. Pack 'chute into the body tube on top of the wadding. Pack the shroud lines and shock cord in on top of the parachute and slip the nose cone into place.

NOTE: DO NOT pack parachute until you are actually ready to launch. For maximum parachute reliability, lightly dust the 'chute with ordinary talcum powder before each flight, especially in cold weather.

T-11

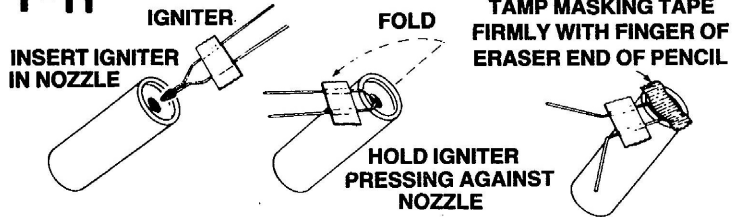

Select an engine and install an igniter as directed in the engine instructions. The engines recommended for use with this rocket are the A8-3, B4-4, B6-4, B8-5, and C6-5 made by Estes. Use a B4-4 engine for your first flight.

T-10

ENGINE HOOK MUST LATCH SECURELY

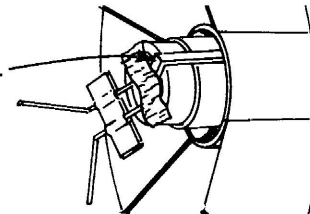

Insert engine into rocket engine mount. Engine hook must latch securely over end of the engine.

T-9

Disarm the launch panel—REMOVE SAFETY KEY!

T-8

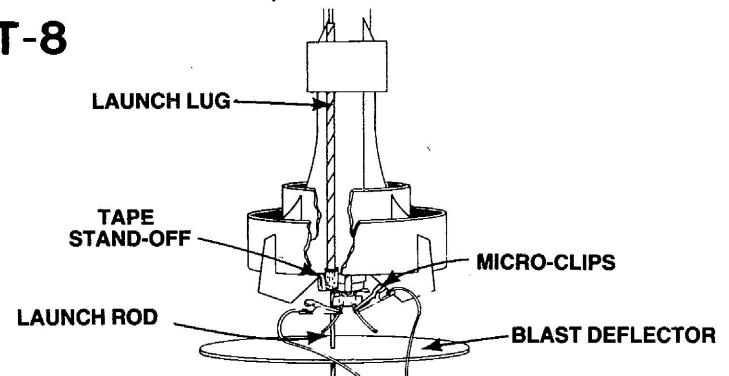

Slide launch rod through rocket launch lug and place rocket on launch pad. Make sure the rocket slides freely on the launch rod. Clean the micro-clips and attach them to the igniter wires. Arrange the clips so they do not touch each other or the metal blast deflector. Attach clips as close to protective tape on igniter as possible.

T-7

Clear the launch area. Alert recovery crew and trackers. Check for low flying aircraft and unauthorized persons in the recovery area.

T-6

Arm the launch panel—INSERT SAFETY KEY!

-5-4-3-2-1-LAUNCH!!

Repeat Countdown Checklist for each flight.

MISFIRE PROCEDURE

Disarm the launch panel. Wait one minute before approaching the rocket on the launch pad. Remove the rocket, clean the igniter residue from the nozzle of the engine, and carefully install a new igniter. Repeat the Countdown Checklist.

Failure of the rocket engine to function properly is nearly always caused by a failure to install the igniter correctly. This failure permits the igniter to heat and burn into two pieces without igniting the engine.

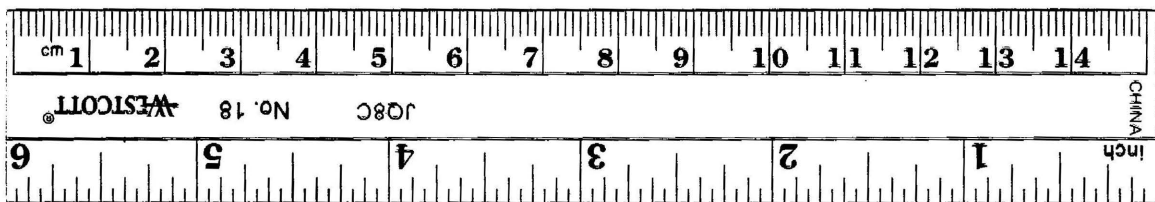
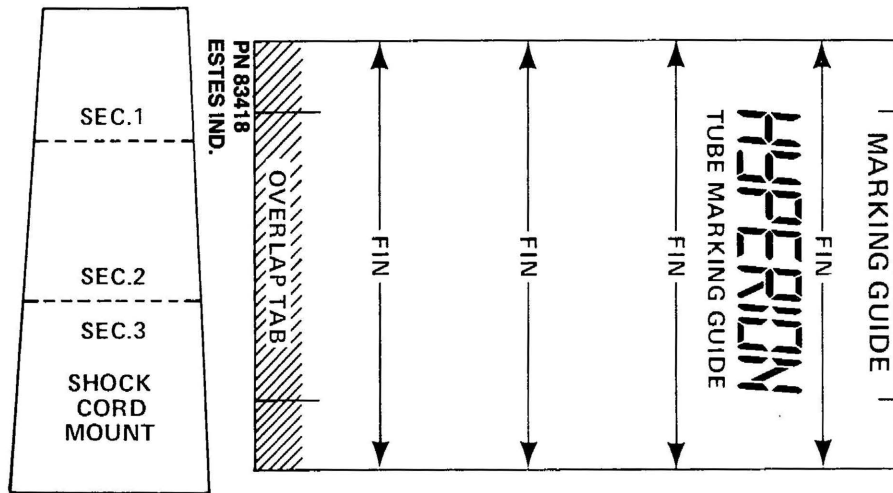
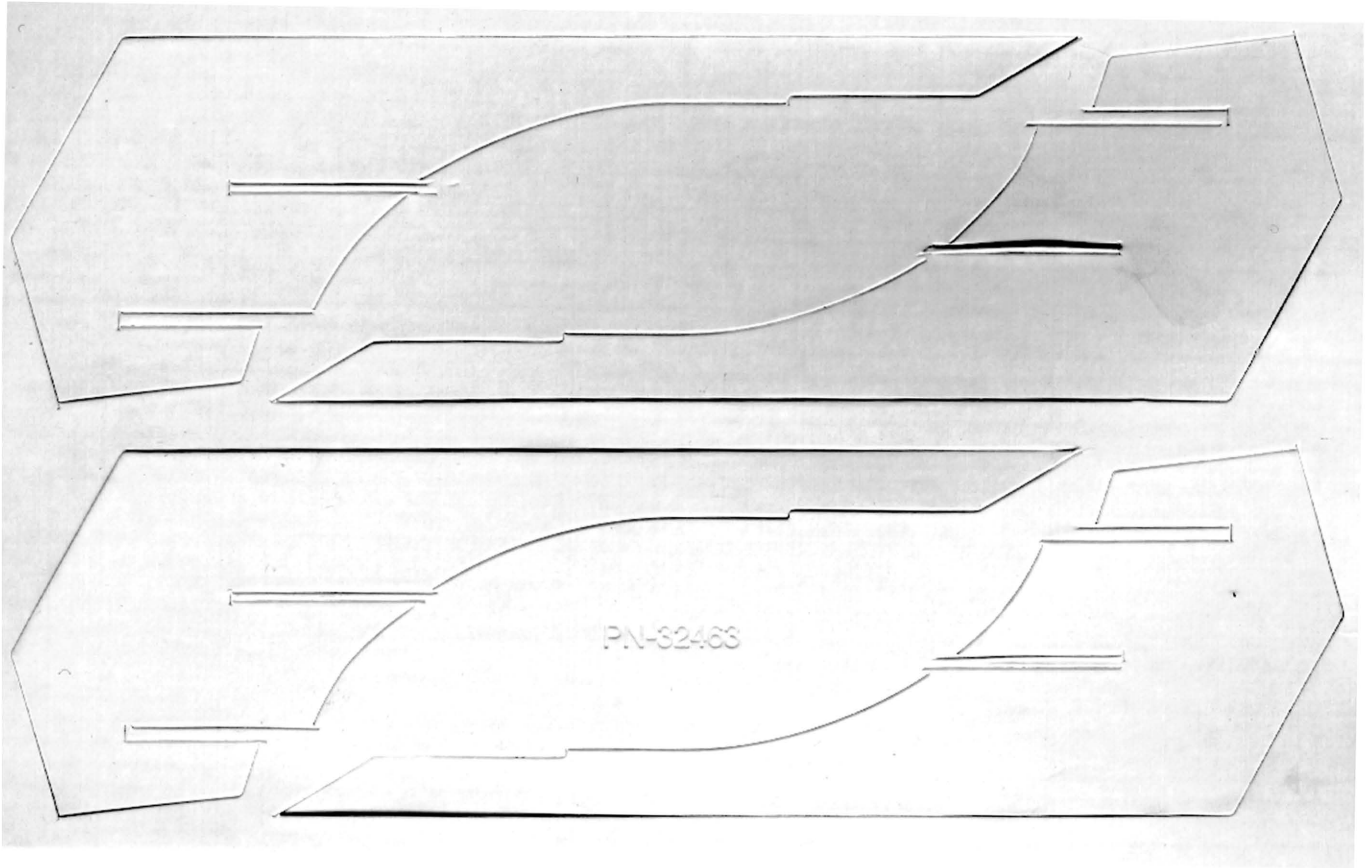



WESTCOTT® 81 No. N 380R

cm 1 2 3 4 5 6 7 8 9 10 11 12 13 14

inch 1 2 3 4 5 6

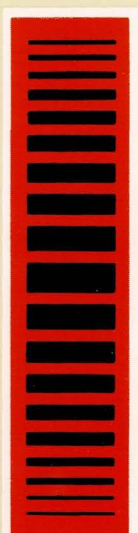
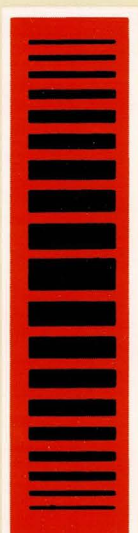

PN37525
ESTES IND.

