



SCRAMBLER

2

SKILL LEVEL 3 - RECOMMENDED FOR THE EXPERIENCED MODEL BUILDER

RECOMMENDED ENGINES:
D12-5 Only

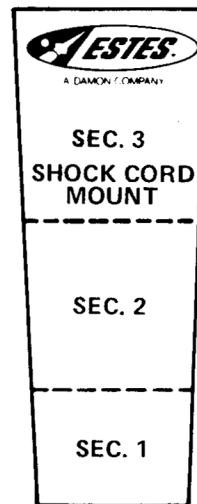

CUT OUT
HERE

BEFORE YOU START

Read each step and study the accompanying drawings before doing any of the work called for in that step. Make sure you have all parts and materials. Check off each step as you complete it. Always test-fit parts together before applying glue. It will sometimes be necessary to sand edges of rings, tubes, etc. to obtain proper fit. If you are in doubt about the relative size or location of some parts, refer back to this exploded view drawing for clarification. Adequate glue joints are very important for a flying model rocket. Follow the instructions carefully in this respect.

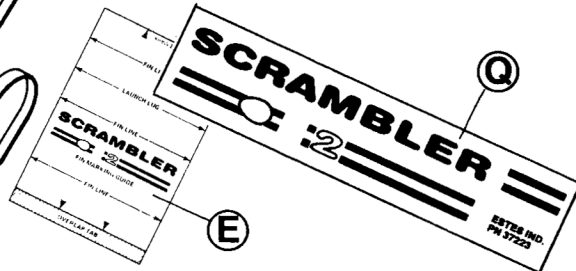
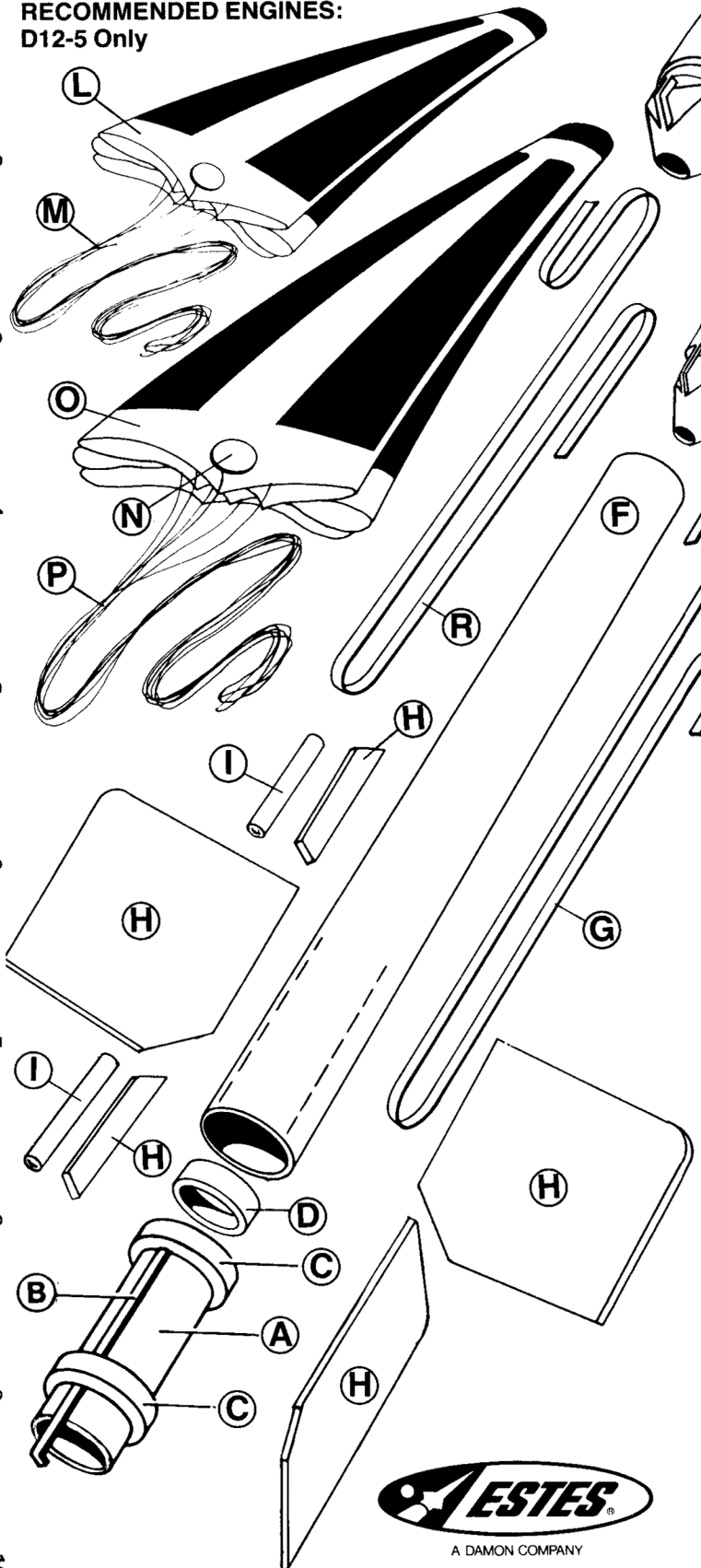

TOOLS AND MATERIALS

In addition to the parts included in this kit you will need: Scissors, pencil, ruler, fine or extra-fine grit sandpaper, sanding sealer, a medium-size modeling paint brush, modeling knife with sharp blade, gloss yellow and black enamel spray paints, tube-type plastic cement and household white glue or resin glue (Elmer's, Titebond, or similar). Other types of glue are not recommended.

For easy and positive alignment of the fins on your model, we recommend the use of Estes' Fin Alignment Guide, Part No. 2231.

PARTS LIST

KIT # 1908

A	1	Engine Mount Tube (type BT-50J)	30362
B	1	Engine Hook (type EH-2)	35025
C	2	Adapter Rings (type AR-5055)	30166
D	1	Engine Block (type AR-2050)	30164
E	1	Body Marking Guide	83639
F	1	Body Tube (type BT-55C)	30383
G	1	Shock Cord (type SC-1)	85730
H	1	Die-Cut Balsa Sheet (type BF-1908)	32608
I	1	Launch Lug (type LL-12)	38166
J	1	Plastic Nose Cone/Adapter (type PNC-60NA)	72057
K	1	Payload Tube (type BT-60R)	30418
L	1	12" Parachute (type PK-12A)	85564
M	1	Shroud Line (type SLT-72)	38237
N	2	Tape Disc (type TD-3F)	38406
O	1	18" Parachute (type PK-18A)	85566
P	1	Shroud Line (type SLT-108)	38239
Q	1	Decal Sheet (type KD-1908)	37223
R	1	Shock Cord 1/4" Wide (type SC-2)	85736



A DAMON COMPANY

ESTES INDUSTRIES
PENROSE, CO 81240 USA

INCHES
1
2
3
4
5
6
7
8
9
10

ASSEMBLY INSTRUCTIONS

1

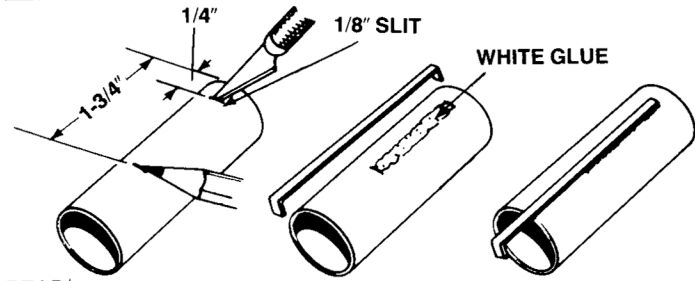

REAR:

Mark the engine mount tube (part A) 1/4" and 1-3/4" from one end. Cut a 1/8" long slit in the tube at the 1/4" mark. Apply a line of glue between the two marks. Push one end of the engine hook (part B) into the slit as shown. Press the main part of the hook into the glue.

2

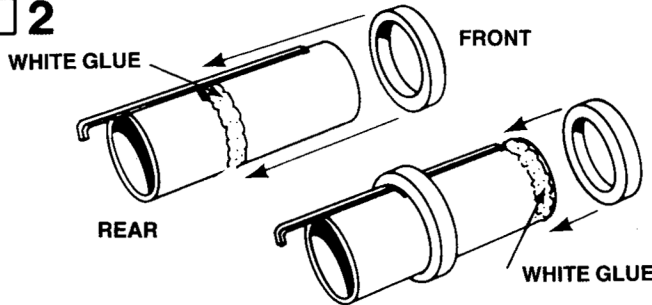

Apply a line of glue around the tube just forward of the 1-3/4" mark. Slide one of the adapter rings (part C) onto the tube from the forward end, over the engine hook, and up to the 1-3/4" mark. Apply a line of glue around the tube just forward of the engine hook. Slide the remaining adapter ring onto the forward end of the tube until it just touches the engine hook.

3

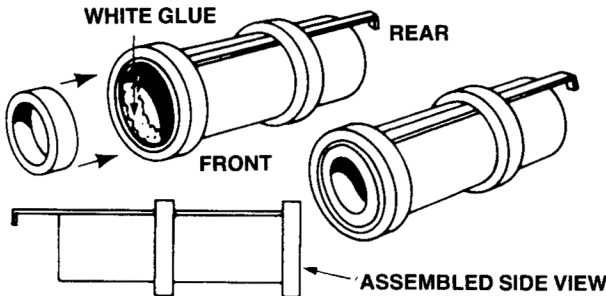

Smear a line of glue around the inside of the forward end of the engine mount tube and push the engine block (part D) in until it stops against the engine hook. Set the unit aside to dry.

4

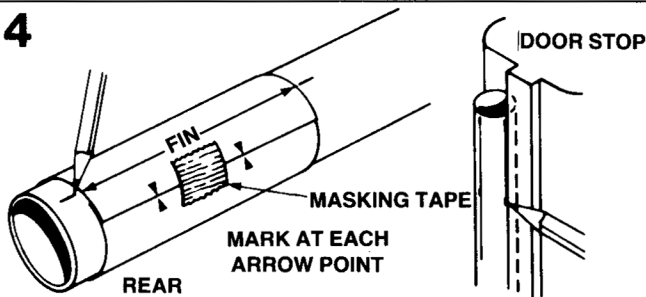

Cut out the body marking guide (part E) from the back of the display panel. Wrap it around one end of the rocket body tube (part F). Match the printed guide marks and tape guide in place. Mark the tube at each arrow point. Remove the guide. Place the body tube against the inside edge of a door frame as shown. Draw a line about 4" long from the tube end through each pair of fin line marks. Draw a line the entire length of the body tube through the launch lug marks. Label this launch lug line. You may prefer to use a ruler to connect the tube marks and draw the alignment lines.

5

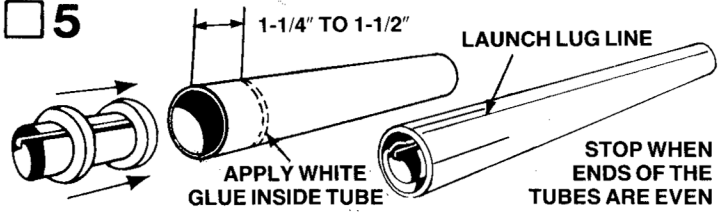

Smear a line of glue around the inside of the rear end of the body tube. The glue line should be about 1-1/4" to 1-1/2" from the end of the tube. Push the engine mount unit in right away -- but be sure the mount is turned so the hook will stick out of the end of the tube. Position the engine mount so that the engine hook is centered with the launch lug line. Push the engine mount in with one smooth motion until the ends of the tubes are even.

6

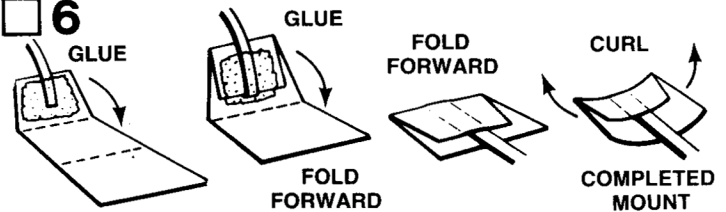

Cut out the shock cord mount from the front page of the instruction sheet. Crease it on the dotted lines by folding. Spread glue on the first section (1) and lay the end of the shock cord (part G) into the glue. Fold over and apply glue to the back of the first section and the exposed part of Section (2). Lay the shock cord as shown and fold over again. Clamp the unit together with your fingers until the glue sets.

7

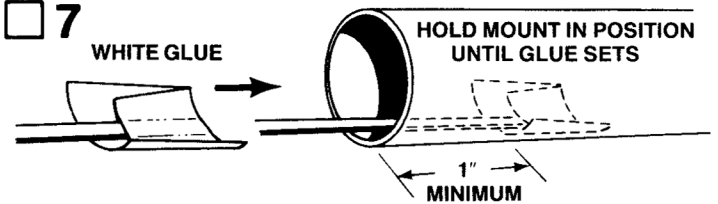

Smear glue over the back side of the balsa sheet mount as shown. Hold the mount so its wide end enters the tube first, and press it into place in the front of the body tube. Make sure the front of the mount is at least 1" from the tube end to allow for the nose cone. Hold the mount in place until the glue sets.

8

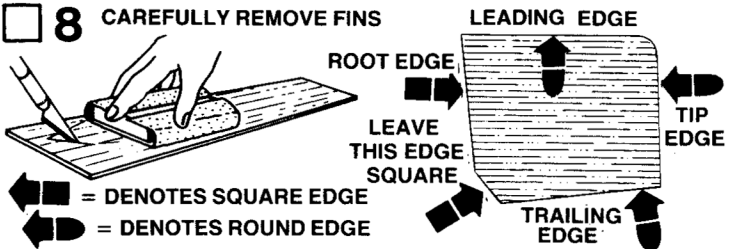

Fine-sand both sides of the balsa sheet (part H). Carefully remove the fins from the sheet using a sharp knife. Sand all fin edges round except the root edge (the edge which glues to the rocket body). The root edge of each fin must be square.

9

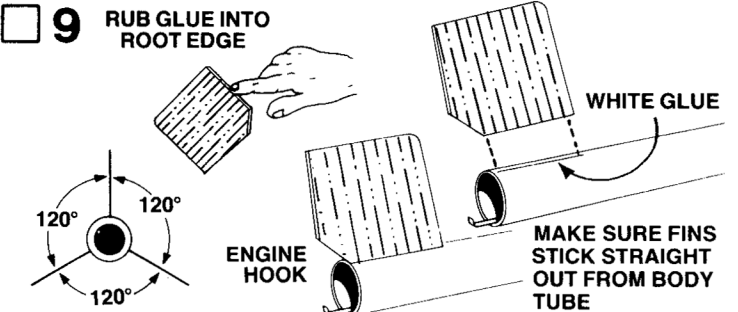

Rub a line of glue into the root edge of each fin and allow to dry. Glue the fins to the body on the alignment lines. The rear of each fin should be even with the rear of the body tube as shown. Adjust the fins so they stick straight out from the body. Do not set the rocket on its fins while the glue is drying.

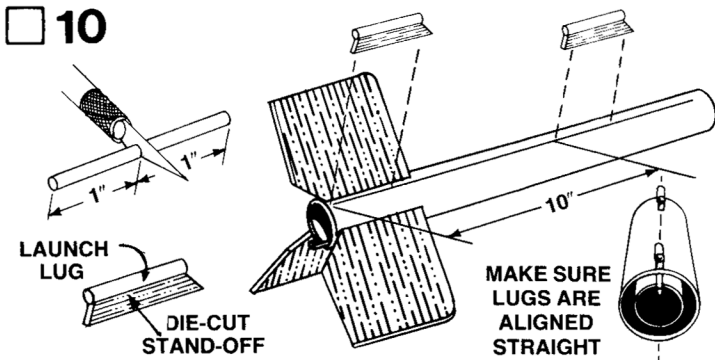

Cut the launch lug (part I) into two 1" lengths. Glue the two lugs to the two balsa launch lug stand-offs as shown. Make sure they are glued straight. Then glue these lug assemblies to the body tube on the launch lug line. The rear stand-off should be glued even with the rear of the body tube. The forward stand-off is glued to the body 10" from the rear of the tube. Sight down the body tube to be sure the lugs are straight before the glue sets.

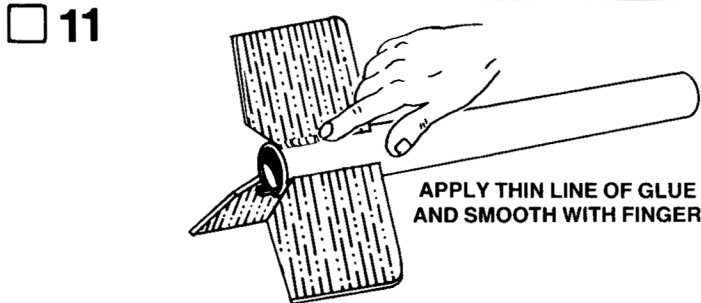

When the fin and stand-off joints have dried, apply glue reinforcements to each joint. Holding the model level, apply a narrow line of glue to both sides of each fin joint. Smooth out the glue with your finger. **IMPORTANT** — Keep the model level until the glue dries.

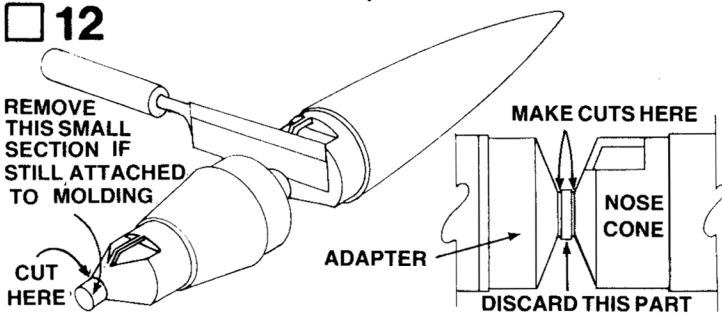

Separate the nose cone/adapter (part J) using either a sharp modeling knife or modeler's saw. Use the grooves molded into the part as cutting guides. Discard the small section of plastic removed between the two parts as it is not used. You will also need to cut away and discard the small tubular section at the base of the adapter if it has not already been removed.

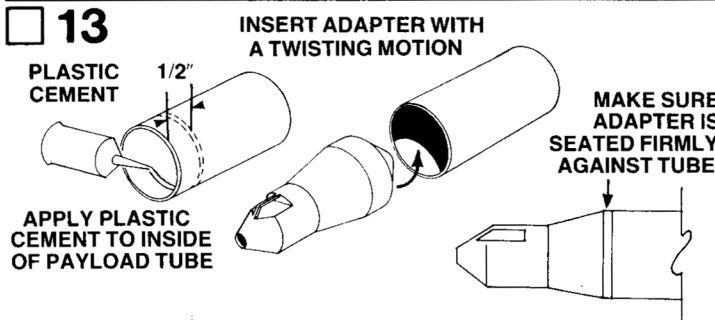

Apply a liberal amount of tube-type plastic cement around the inside of one end of the payload tube (part K). The cement should be about 1/2" from the end of the tube. Insert the adapter with a twisting motion until its shoulder is seated firmly against the payload tube end. Set aside to dry thoroughly. Insert the nose cone into the payload tube, but do not glue it into place.

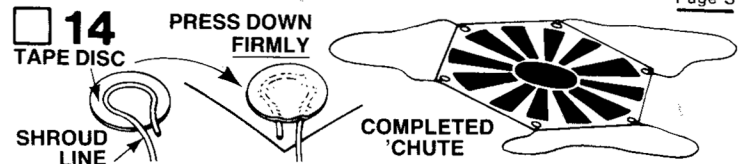

Cut out the 12" parachute (part L) on its edge lines. Cut three equal lengths of shroud line from the 72" long shroud line (part M). Attach line ends to the top of the parachute with one set of tape discs (part N) as shown. Form a small loop in the end of the shroud line. Holding the loop, gently center it inside the tape disc on the sticky side. Then carefully press the disc onto its proper place on top of the parachute. **Firmly** press the tape disc into place until both the disc and parachute material are molded around the shroud line loop. Repeat for the other shroud line ends and tape discs. Set the completed parachute aside until needed in Step 20.

Cut out the 18" parachute (part O) and assemble it with the 108" shroud line hemp (part P) and the remaining tape disc set. Use the same method to attach the shroud lines and tape discs as for the 12" parachute. Set this completed parachute aside until needed in Step 21.

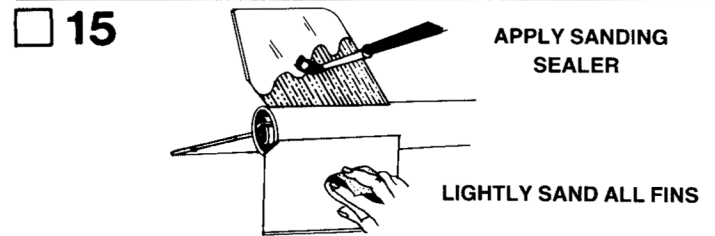

Proper application of sanding sealer makes the rocket look better and reduces drag so that the rocket will fly higher. However, this step is not essential to make a safe, attractive rocket. Apply a coat of sanding sealer to each fin. When sealer is dry, lightly sand all the sealed surfaces. Repeat sealing and sanding process until balsa grain is filled and smooth.

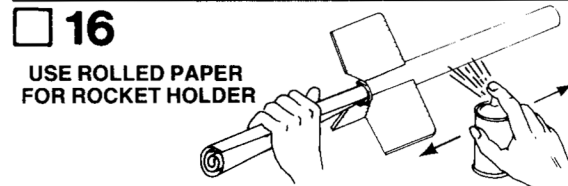

After the sanding sealer is completely dry, paint the entire booster section bright yellow. Follow instructions on the spray can for best results. We recommend spray enamel. Do not paint the model with lacquer paint. Shake can before spraying. Hold the can straight up and spray in long, smooth "strokes". Spray the model with several light, dry mist coats of paint to avoid "runs". Shake can periodically. To obtain a gloss, final coat should be applied slightly heavier. Let this coat dry overnight.

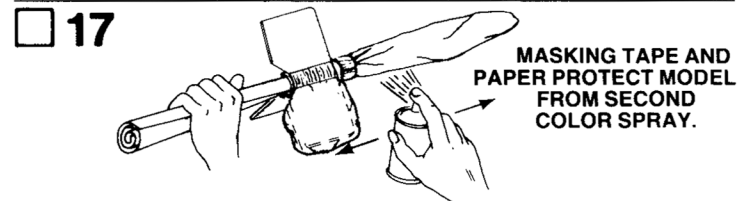

After the yellow paint has dried, apply masking tape and paper to protect one fin and the body tube which will remain yellow. (See the Decor Layout illustration.) Paint the remaining two fins Gloss Black. Carefully remove the masking tape and paper as soon as the paint is dry.

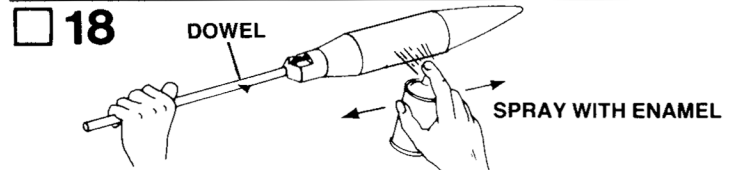

Spray paint the payload section with several light coats of black paint. The payload section can be supported by a dowel or stick inserted in the center opening in the adapter while being painted and drying.

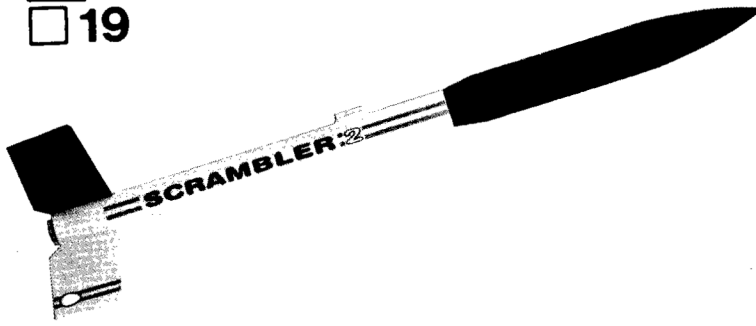

When all paint is dry, apply the decals (part Q) in the positions shown. (A) Cut only one decal at a time from sheet. (B) Submerge decal in lukewarm water until decal slides on backing paper (usually 15 to 30 seconds). (C) Gently slide decal from backing paper onto model. (D) Move decal into exact position and carefully blot away excess water with a soft cloth. (E) If the decal "sticks" before you have it in position, apply water over the decal with a brush. This will permit the decal to be moved. (F) Smooth out all wrinkles and air bubbles before the decal dries. We recommend that the completed model be sprayed with Tesor's "Gloss Cote". This is a clear spray paint that protects the model's finish.

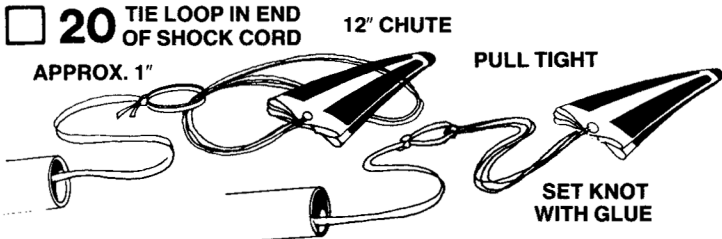

20 TIE LOOP IN END OF SHOCK CORD 12" CHUTE
 APPROX. 1" PULL TIGHT SET KNOT WITH GLUE

Tie a loop in the free end of the shock cord. The loop should be about 1" in diameter. Pass the shroud line loops of the 12" 'chute through the loop in the shock cord. Pass the parachute through the loop ends and draw the lines tight against the shock cord loop. Set the knot with a drop of glue.

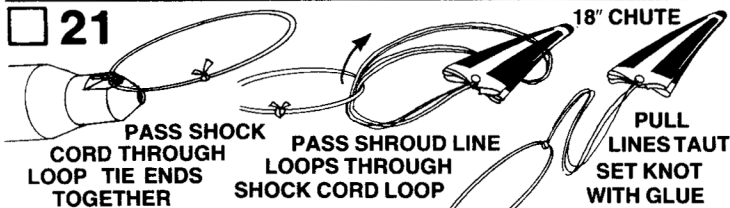

21 18" CHUTE
 PASS SHOCK CORD THROUGH LOOP TIE ENDS TOGETHER PASS SHROUD LINE LOOPS THROUGH SHOCK CORD LOOP PULL LINES TAUT SET KNOT WITH GLUE

Pass one end of the 1/4" wide shock cord (part R) through the loop in the bottom of the payload adapter. Tie the two ends of the shock cord together with a double knot. Position the shock cord loop in the adapter so that the knot is half-way between the adapter and the end of the loop. Pass the shroud line loops of the 18" parachute through the shock cord loop. Pass the parachute through the loop ends and draw the lines tight against the shock cord loop. Set the knot with a drop of glue.

LAUNCH AN EGG!?

The Scrambler 2 was designed as a sport model for lofting of all things--EGGS! Launching an egg provides lots of fun and excitement without risking the life of an innocent small creature. Select a small egg which will slide easily into the payload compartment. Place the egg in a small plastic bag and seal the bag. Make a cushion of foam rubber or crumpled tissue paper in the bottom of the payload compartment. Carefully slide in the egg. Top the egg with another pad of foam rubber or tissue, and then push the nose cone firmly into place. The fit of the nose cone is extremely important in keeping the egg secure. If the fit is too loose, add layers of masking tape around the base of the nose cone until the fit is good and snug, yet not so tight that it cannot be removed. Now see if you can launch and recover the egg without breaking either the shell or yolk!

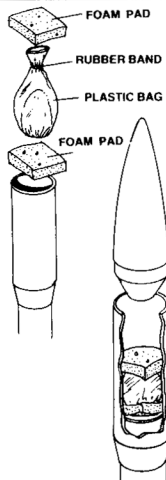

LAUNCHING COMPONENTS

To launch your rocket you will need the following items:

- An Estes model rocket launching system
- Flame retardant recovery wadding (Estes Cat. No. 2274).
- Estes D12-5 model rocket engines only.

Be sure to follow the HIAA-NAR* Model Rocket Safety Code when carrying out your model rocket activities.

*HIAA—Hobby Industry of America

*NAR—National Association of Rocketry

COUNTDOWN CHECKLIST

T-13 Pack 4 to 6 squares of loosely crumpled recovery wadding into main body tube. The wadding should fill the bottom of the parachute compartment for at least two inches.

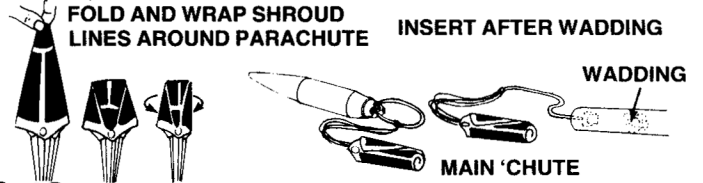

T-12 Loosely fold the main parachute and lay it on top of the wadding, with its shroud lines and shock cord on top of it. Fold and pack the parachute for the payload section on top of the main 'chute. Slide the payload section into place.

NOTE: DO NOT pack parachute until you are actually ready to launch. For maximum parachute reliability, lightly dust the 'chute with ordinary talcum powder before each flight, especially in cold weather.

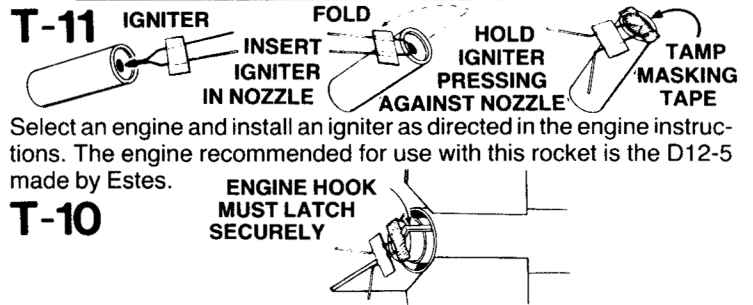

T-11 Select an engine and install an igniter as directed in the engine instructions. The engine recommended for use with this rocket is the D12-5 made by Estes.

T-10 Disarm the launch panel—REMOVE SAFETY KEY!

T-9 Slide launch rod through rocket launch lug and place rocket on launch pad. Make sure the rocket slides freely on the launch rod. Clean the micro-clips and attach them to the igniter wires. Arrange the clips so they do not touch each other or the metal blast deflector. Attach clips as close to protective tape on igniter as possible.

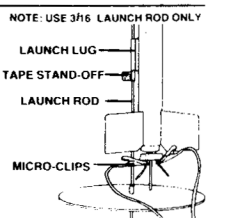

T-8 Clear the launch area. Alert recovery crew and trackers. Check for low flying aircraft and unauthorized persons in the recovery area.

T-7 Arm the launch panel—INSERT SAFETY KEY!

5-4-3-2-1-LAUNCH!!

Repeat Countdown Checklist for each flight.

MISFIRE PROCEDURE

Disarm the launch panel. Wait one minute before approaching the rocket on the launch pad. Remove the rocket, clean the igniter residue from the nozzle of the engine, and carefully install a new igniter. Repeat the Countdown Checklist.

Failure of the rocket engine to function properly is nearly always caused by a failure to install the igniter correctly. This failure permits the igniter to heat and burn into two pieces without igniting the engine.

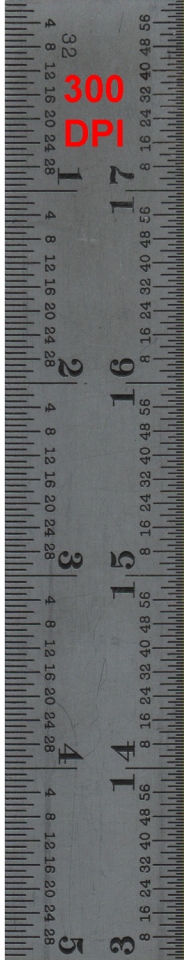
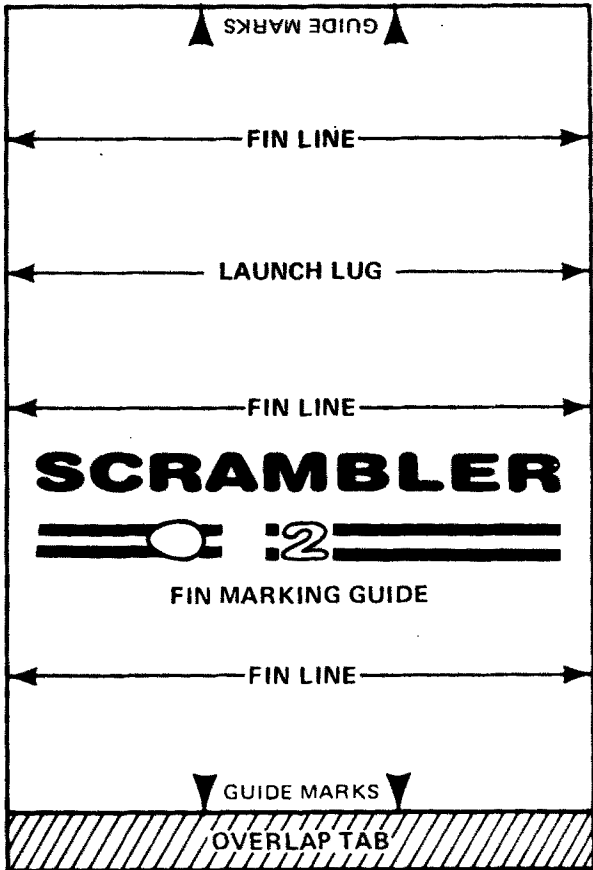

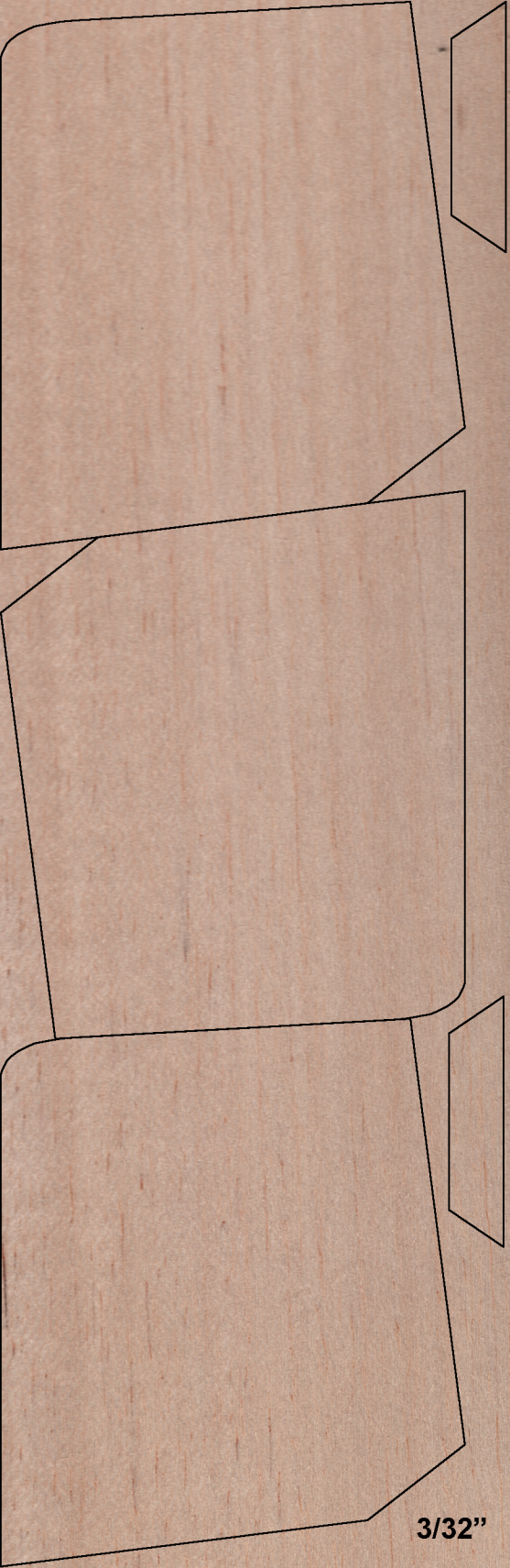

3/32"

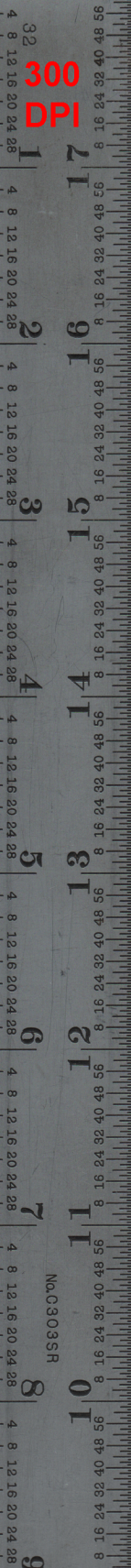

300
DPI

No.C303SR

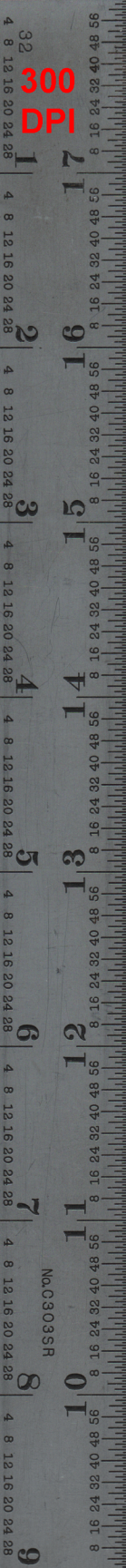

SCRAMBLER



**ESTES IND.
PN 37223**

PARTS LIST KIT NO. 1908 - Scrambler 2

Quantity	Description	Type	Number	Detail1	Detail2	Detail3	Detail4	Comment
1	PAPER BODY TUBE	BT-50J	30362	2.75" long	0.950" ID	0.976" OD	0.013" wall	Glassine
1	ENGINE HOLDER	EH-2	35025	2.8" long	.100" wide	.025" thick		Reg. & D
2	CENTERING RINGS	AR-5055	30166	.977" ID	1.27" OD	0.25" long		
1	CENTERING RINGS	AR-2050	30164	0.25" long	0.737" ID	0.949" OD	0.106" wall	Green
1	Body Marking Guide	SP-1908	83639	3.5" wide	5" long	Heavy Cardstock		Scan
1	PAPER BODY TUBE	BT-55C	30383	14" long	1.283" ID	1.325" OD	0.021" wall	Glassine
1	Shock Cord	SC-1	85730	18" long	1/8" wide			Rubber
1	BALSA FIN STOCK	*BFS-30	32108	3" wide	9" long	3/32" thick	0.09375	Scan
1	LAUNCH LUG	LL-12	38166	5/32" ID	1/8" rod	2" long		Mylar
1	PLASTIC NOSE CONE	*PNC-60NA	72057	4.75" long	1.627" dia.	.75" shoulder	With TA-5560 attached	Blow molded
1	PAPER BODY TUBE	BT-60R	30418	5" long	1.595" ID	1.637" OD	0.021" wall	
1	Parachute	PK-12A	85564	12" hexagon	1.25 mil thick	LDPE plastic	Org/Wht	
1	Shroud Line	SLT-72	38237	72"	.020" diameter	Twisted cotton		
2	Tape Disc	TD-3F	38406	1/2" dia.	Paper	Self-Stick		Set of 6
1	Parachute	PK-18A	85566	18" dia.	18" x 6 Shrouds	LDPE plastic	Org/Wht	
1	Shroud Line	SLT-108	38239	108"	.020" diameter	Twisted cotton		
1	Decal Sheet	KD-1908	37223	3" wide	9" long	Red/Wht/Blk	Waterslide	Scan
1	Shock Cord	SC-2	85736	18" long	1/4" wide			Rubber

* Die-Cut Balsa Sheet BF-1908 Part #32608

* Same used for Loadstar II #3227

SCRAMBLER: 2

FLYING MODEL ROCKET

SKILL LEVEL 3

1-Beginner 2-Intermediate 3-Craftsman
4-Advanced 5-Expert

- Flights to 1000 Feet
- D Powered Egglofter
- Dual Parachute Recovery
- Three Color Decal
- Die-Cut Balsa Fins
- Plastic Nose Cone
- Quick Release Engine Mount

Length: 25.4 in. (64.5 cm)

Dia.: 1.32 in. (33.5 mm)

Payload Dia.: 1.64 in. (41.6 mm)

Weight: 3.2 oz. (90 g)

Engine Types: D12-5



This is a hobby kit requiring assembly.
Recommended for ages 10 to adult.
Engines, launch system, glue and finishing
supplies are not included. Adult supervision
is suggested for those under 12 years of age
when flying model rockets.

#1908



A UAMCON COMPANY

ESTES INDUSTRIES
PENROSE, CO 81240 USA