



Last Copy

HARPOON

SKILL LEVEL 1

Recommended for Beginning Rocketeers

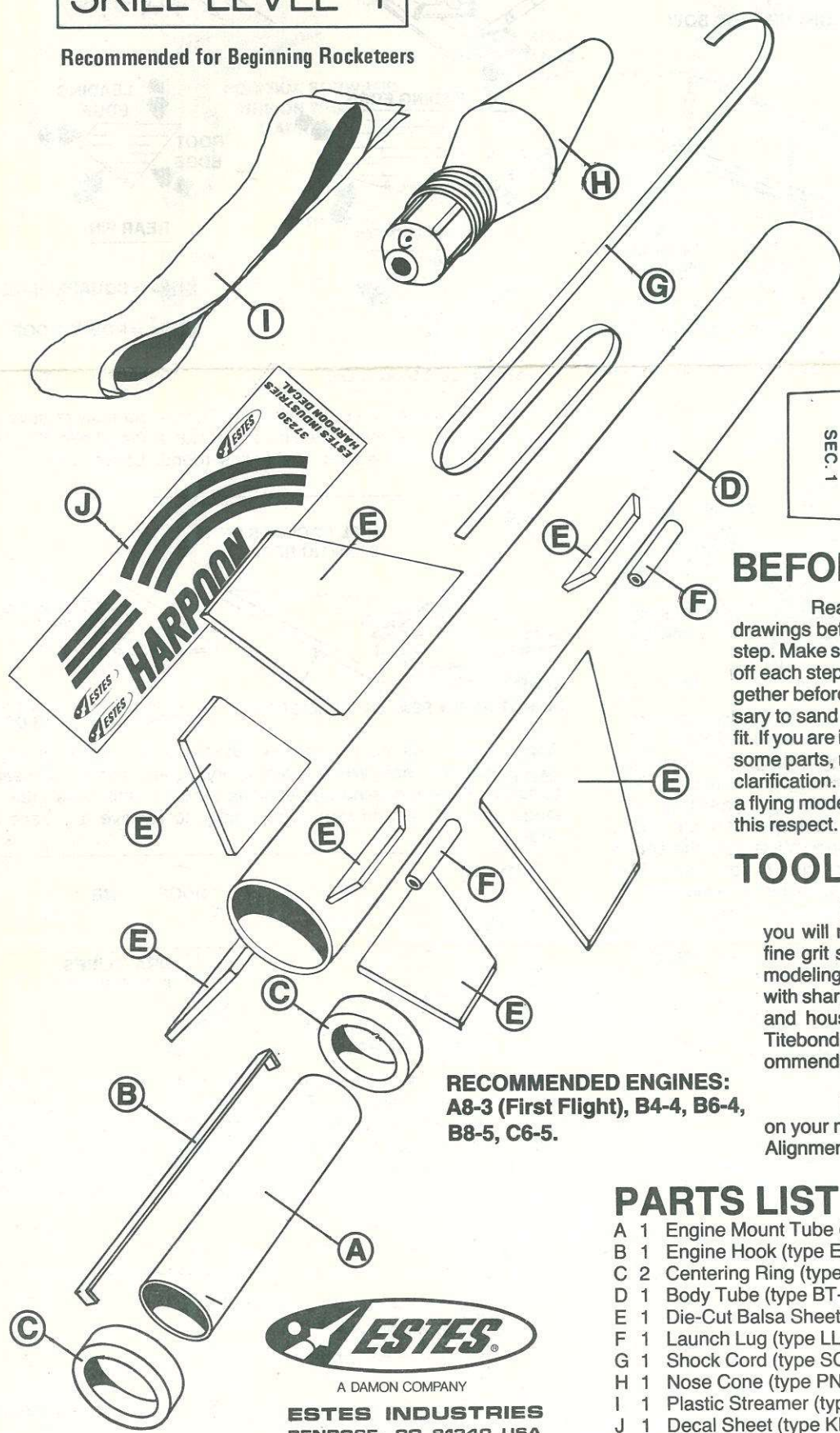
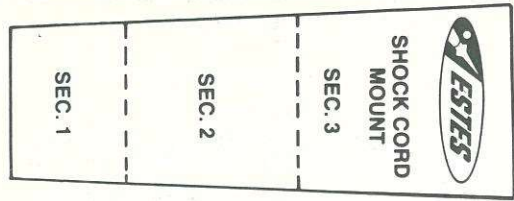
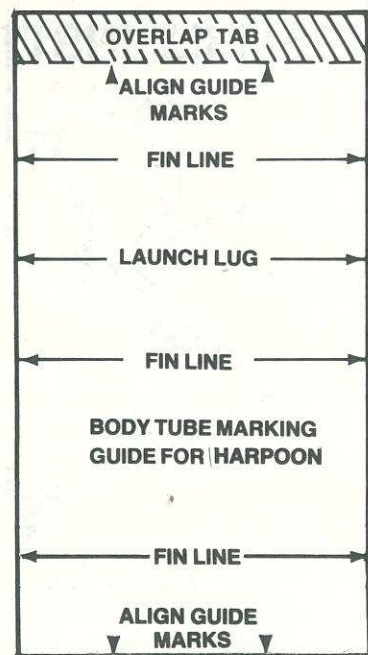

RECOMMENDED ENGINES:
A8-3 (First Flight), B4-4, B6-4,
B8-5, C6-5.

BEFORE YOU START

Read each step and study the accompanying drawings before doing any of the work called for in that step. Make sure you have all parts and materials. Check off each step as you complete it. Always test-fit parts together before applying glue. It will sometimes be necessary to sand edges of rings, tubes, etc. to obtain proper fit. If you are in doubt about the relative size or location of some parts, refer back to this exploded view drawing for clarification. Adequate glue joints are very important for a flying model rocket. Follow the instructions carefully in this respect.

TOOLS AND MATERIALS

In addition to the parts included in this kit you will need: Scissors, pencil, ruler, fine or extra-fine grit sandpaper, sanding sealer, a medium-size modeling paint brush, masking tape, modeling knife with sharp blade, gloss dark blue enamel spray paint, and household white glue or resin glue (Elmer's, Titebond, or similar). Other types of glue are not recommended.

For easy and positive alignment of the fins on your model, we recommend the use of Estes' Fin Alignment Guide, Part No. 2231.

PARTS LIST

KIT NO. 1915

A	1	Engine Mount Tube (type BT-20J)	30326
B	1	Engine Hook (type EH-2)	35025
C	2	Centering Ring (type AR-2050)	30164
D	1	Body Tube (type BT-50W)	30372
E	1	Die-Cut Balsa Sheet (type BF-1915)	32615
F	1	Launch Lug (type LL-2A)	38175
G	1	Shock Cord (type SC-1)	85730
H	1	Nose Cone (type PNC-50U)	72046
I	1	Plastic Streamer (type RS-20)	38272
J	1	Decal Sheet (type KD-1915)	37230

\$12.50



A DAMON COMPANY

ESTES INDUSTRIES
PENROSE, CO 81240 USA

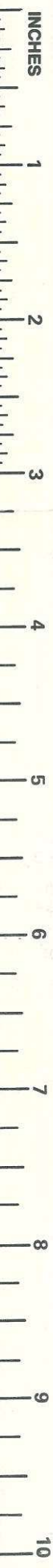

ASSEMBLY INSTRUCTIONS

1

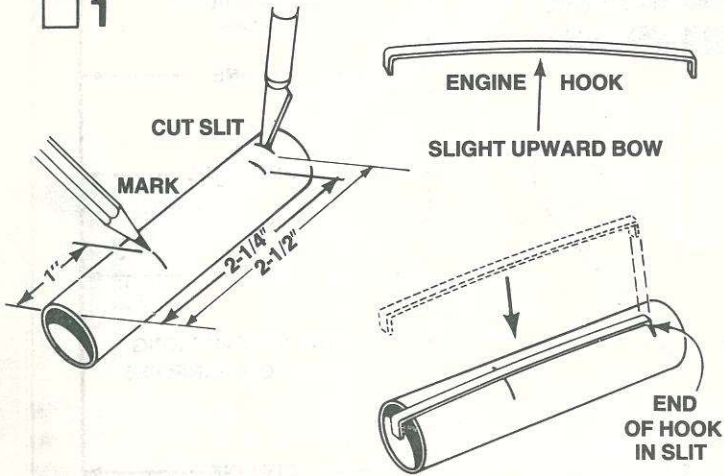

Mark the engine mount tube (part A) at 1", 2-1/4" and 2-1/2" from one end. Cut a 1/8" wide slit at the 2-1/2" mark. Gently bend the engine hook (part B) so that it bows upward very slightly in the middle. (Study the drawing—Don't bend the wrong way.) Insert one end of the engine hook into the slit in the tube.

2

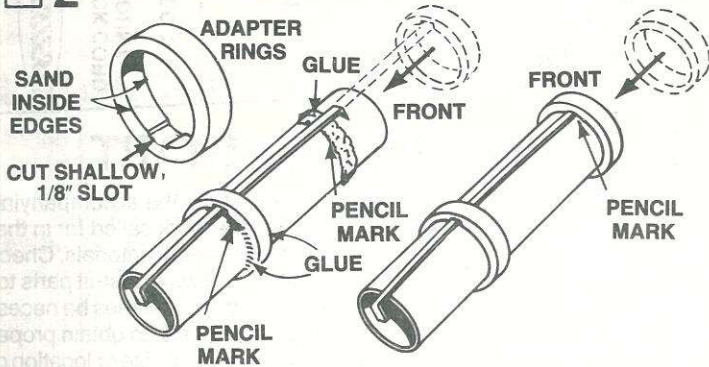

Sand the inside edges of the two centering rings (part C) to remove burrs. The rings should slide easily onto the engine mount tube. Cut a very shallow 1/8" wide slot inside the two centering rings so they will fit over the engine hook. Slip one ring onto the front end of the engine mount tube and slide it down to the 1" mark. Make sure the engine hook runs straight down the tube, then apply glue to both sides of this ring. Apply glue around the tube at the 2-1/4" mark and slide the remaining centering ring into place down to the 2-1/4" mark.

3

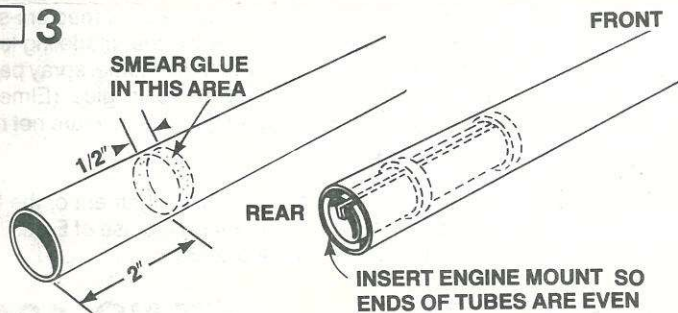

The engine mount unit will be pushed into place so that the rear of the engine mount unit (end with engine hook projecting) is even with the rear of the body tube. Test-fit the engine mount unit several times by smoothly inserting and removing it. Sand if necessary to assure a smooth fit. Once this can be smoothly and easily done, remove the engine mount unit. Apply a ring of glue around the inside of the rear of the main body tube (part D) about 2" to 2-1/2" from the end of the tube. Make certain that the engine hook is to the rear and insert the engine mount unit with one smooth motion. Do not pause, or the glue may "lock" with the engine mount unit in the wrong position.

4

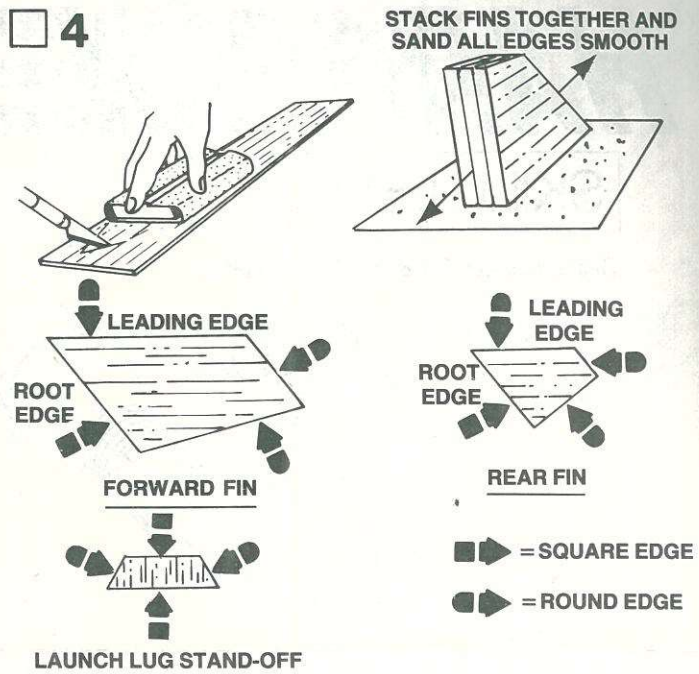

Fine sand the balsa die-cut sheet (part E), then carefully remove the die-cut fins from the sheet. Free the edges with a sharp knife. Sand the leading and trailing edges of the fins round. Leave other edges square.

5

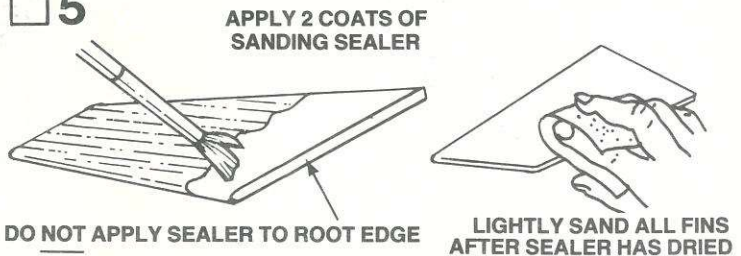

Apply a coat of sanding sealer to each fin. Apply sealer to all edges except the root edge. When sealer is dry, lightly sand all the sealed surfaces. Repeat sealing and sanding process until balsa grain no longer shows. Resand root edge, lightly, to remove any trace of sealer.

6

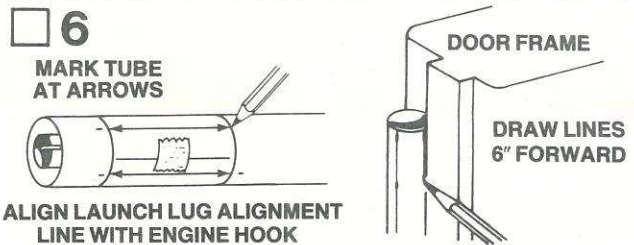

Cut out the tube marking guide from the front of the instructions and wrap it around the body tube. Place the tube marking guide so that the engine hook will line up with the launch lug placement line (arrow point). Mark the body tube at each of the arrow points. Draw straight lines connecting each pair of marks. A door frame inside edge can be used as a guide as shown. Extend the lines about 6" forward from the rear of the tube.

7

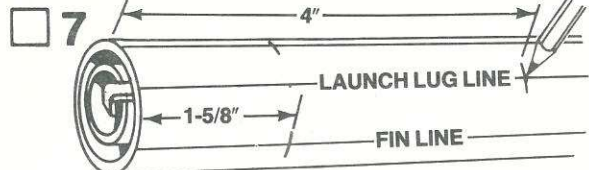

Make a mark on each fin alignment line 1-5/8" from the rear of the tube. Make a mark on the launch lug line 4" from the rear of the tube.

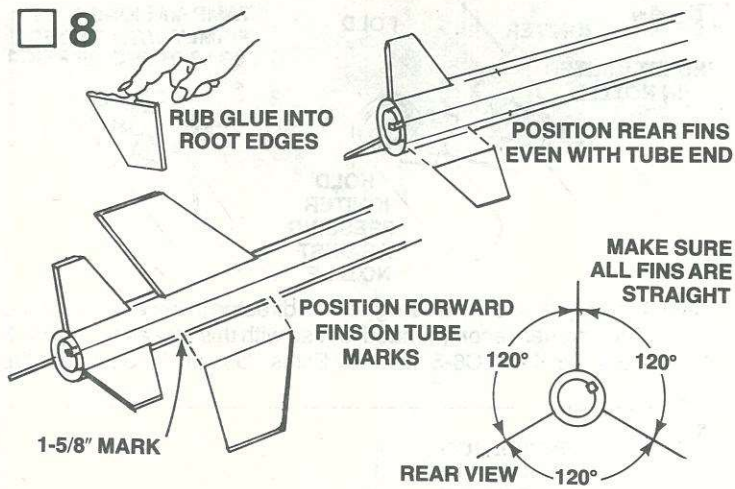

Rub glue into the root edge of each fin and allow to dry. Apply glue to the fins again and position fins on the alignment lines in positions shown. Adjust the fins so they project straight away from the body tube. DO NOT set the rocket on its fins while the glue is wet.

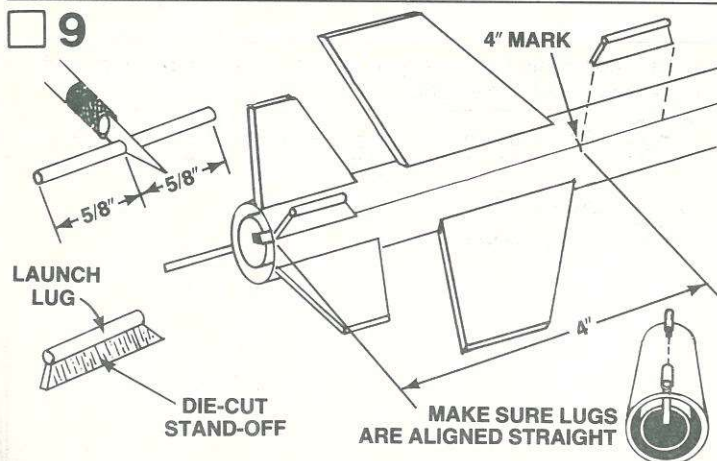

Cut the launch lug (part F) into two 5/8" lengths. Glue the two lugs to the two balsa launch lug stand-offs as shown. Make sure they are glued straight. Then glue these lug assemblies to the body tube on the launch lug line. The rear stand-off should be glued even with the rear of the tube. The forward stand-off is glued to the body 4" from the rear of the tube. Sight down the body tube to be sure the lugs are straight before the glue sets.

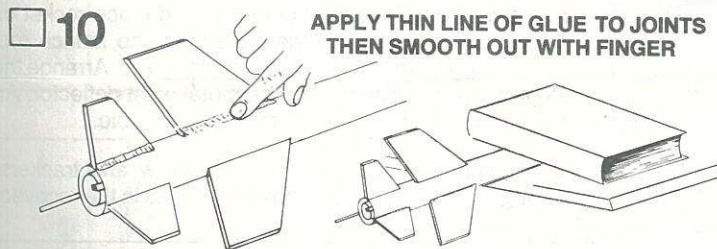

When the glue on the fin joints has dried, apply a glue reinforcement to each fin/body tube joint. Holding the model level, apply a line of glue to both sides of each fin joint and on both sides of the launch lug/stand-off. Smooth out the glue with your finger. IMPORTANT: Support rocket on the table edge as shown until the glue dries.

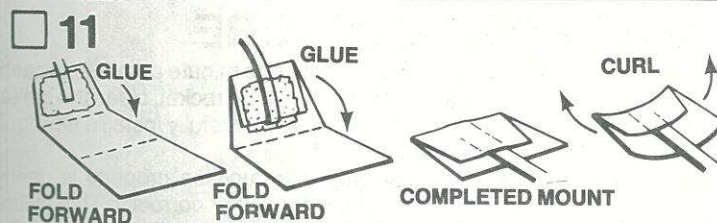

Cut out the shock cord mount from page one. Fold on dotted lines, then unfold and apply glue to Section 1. Lay the end of the shock cord

(part G) into the glue. Fold over and apply glue to the back of Section 1 and the exposed portion of Section 2. Fold again to complete mount. Curl the edges of the mount up so it will match the contour of the body tube and hold with your fingers until the glue sets.

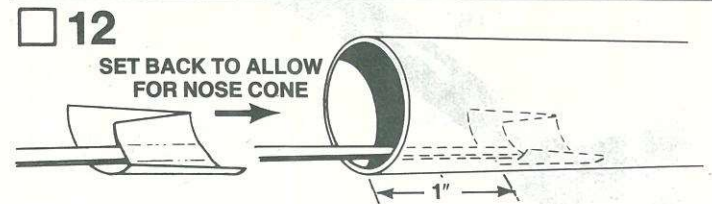

Use a finger or stick to apply glue to the inside of the body tube, 1" to 2" from the front of the tube. Press the shock cord mount firmly into position in glue far enough from the front edge of the tube to allow clearance for the nose cone to fit into place. To insure a good bond use a stick or your finger and smear a film of glue over the mount and surrounding area in the body tube.

PAINTING AND DETAILING

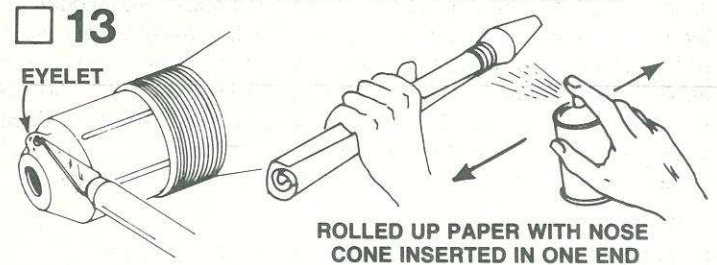

Trim away the excess plastic from the nose cone eyelet and from around the nose cone (part H). Spray paint the nose cone with several light coats of dark blue spray paint. The nose cone can be supported by wrapping newspaper around the shoulder of the nose cone and securing it with masking tape.

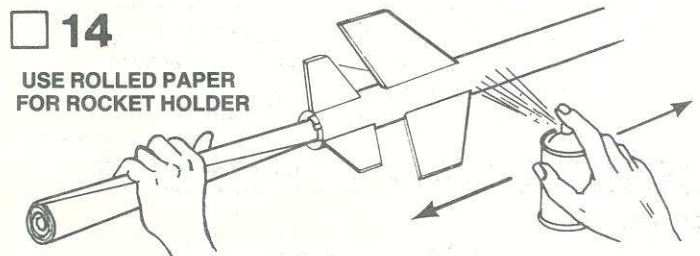

After the sanding sealer is completely dry, paint the entire rocket body and fins with dark blue spray enamel. Follow instructions on the spray can for best results. We recommend spray enamel. Do not paint the model with lacquer paint. Shake can before spraying. Hold the can straight up and spray in long, smooth "strokes". Spray the model with several light, dry mist coats of paint to avoid "runs". Shake can periodically. To obtain a gloss, a final coat should be applied slightly heavier. Let the coat dry overnight. Be sure paint is completely dry before applying decals.

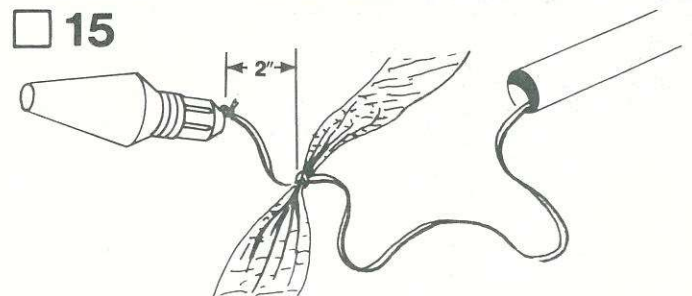

Using a double knot, tie the shock cord around the middle of the plastic streamer (part I) about 2" from the end of the shock cord. Attach the free end of the shock cord to the nose cone with a firm knot.

□ 16



APPLY DECAL STRIPE BELOW RAISED LINE OF NOSE CONE

When all paint is dry, apply the decals (part J) in the positions shown. (A) Cut only one decal at a time from sheet. (B) Submerge decal in lukewarm water until decal slides on backing paper (usually 15 to 30 seconds). (C) Gently slide decal from backing paper onto model. (D) Move decal into exact position and carefully blot away excess water with a soft cloth. (E) If the decal "sticks" before you have it in position, apply water over the decal with a brush. This will permit the decal to be moved. (F) Smooth out all wrinkles and air bubbles before the decal dries. We recommend that the completed model be sprayed with Testor's "Dull Cote". This is a flat clear spray paint that protects the model's finish.

LAUNCHING COMPONENTS

To launch your rocket you will need the following items:

- An Estes model rocket launching system
- Flame resistant recovery wadding (Estes Cat. No. 2274)
- Estes A8-3 B4-4, B6-4, B8-5, and C6-5 model rocket engines. Use an A8-3 engine for your first flight.

Be sure to follow the HIAA-NAR* Model Rocket Safety Code when carrying out your model rocket activities.

- *HIAA—Hobby Industry of America
- *NAR—National Association of Rocketry

COUNTDOWN CHECKLIST

T-13

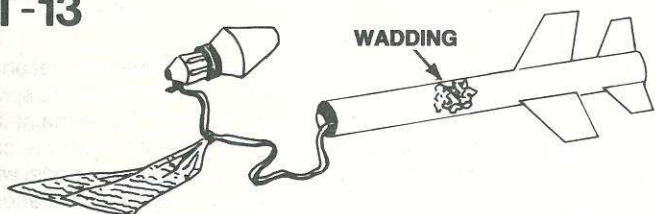

Pack 2 or 3 squares of loosely crumpled recovery wadding into the body tube. Usually this will fill the body tube for a distance equal to about 1-1/2 times its diameter.

T-12

FOLD STREAMER IN HALF TWICE

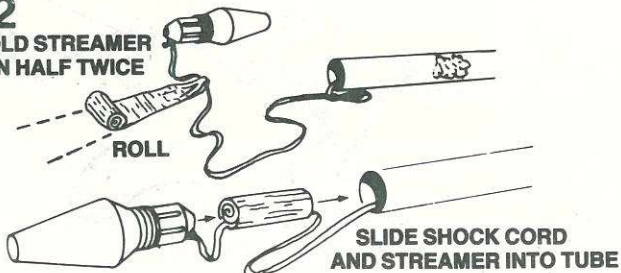

ROLL

SLIDE SHOCK CORD AND STREAMER INTO TUBE

Fold the streamer in half lengthwise. Fold again, then roll streamer tightly until the streamer fits loosely into the rocket body. Pack the shock cord neatly into the rocket body. Slide nose cone into place.

T-11

IGNITER
INSERT IGNITER IN NOZZLE

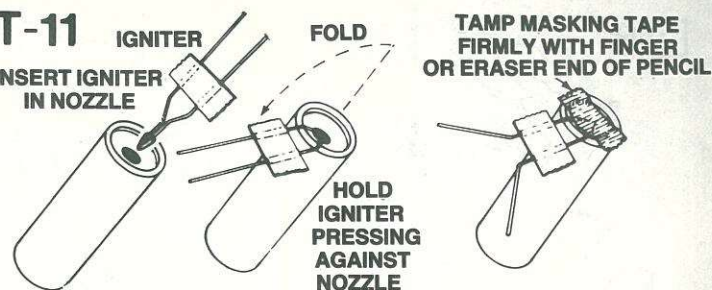

FOLD

TAMP MASKING TAPE FIRMLY WITH FINGER OR ERASER END OF PENCIL

HOLD IGNITER PRESSING AGAINST NOZZLE

Select an engine and install an igniter as directed in the engine instructions. The engines recommended for use with this rocket are the A8-3, B4-4, B6-4, B8-5 and C6-5 made by Estes. Use an A8-3 for your first flight.

T-10

ENGINE HOOK MUST LATCH SECURELY

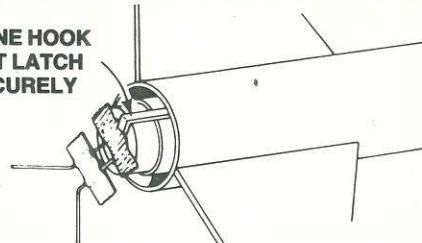

Insert engine into rocket engine mount. Engine hook must latch securely over end of the engine.

T-9

Disarm the launch panel—REMOVE SAFETY KEY!

T-8

LAUNCH LUG
LAUNCH ROD

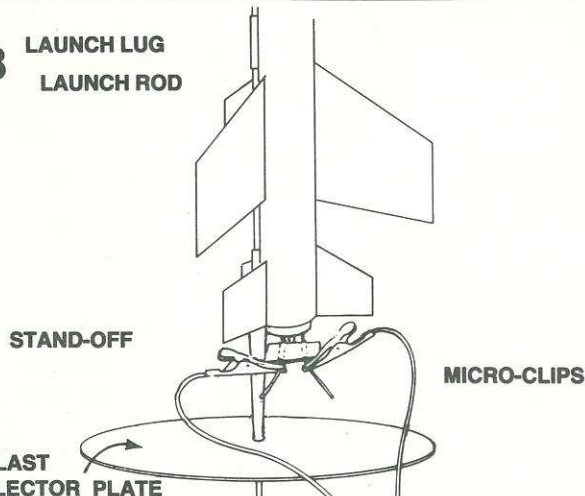

STAND-OFF

MICRO-CLIPS

BLAST DEFLECTOR PLATE

Slide the launch rod through rocket launch lug and place rocket on launch pad. Make sure the rocket slides freely on the launch rod. Clean the micro-clips and attach them to the igniter wires. Arrange the clips so they do not touch each other or the metal blast deflector. Attach clips as close to protective tape on igniter as possible.

T-7

Clear the launch area. Alert recovery crew and trackers. Check for low flying aircraft and unauthorized persons in the recovery area.

T-6

Arm the launch panel—INSERT SAFETY KEY!

5-4-3-2-1-LAUNCH!!

Repeat Countdown Checklist for each flight.

MISFIRE PROCEDURE

Disarm the launch panel. Wait one minute before approaching the rocket on the launch pad. Remove the rocket, clean the igniter residue from the nozzle of the engine, and carefully install a new igniter. Repeat the Countdown Checklist.

Failure of the rocket engine to function properly is nearly always caused by a failure to install the igniter correctly. This failure permits the igniter to heat and burn into two pieces without igniting the engine.

1 Inch

1 Inch

1 Inch

1 Inch

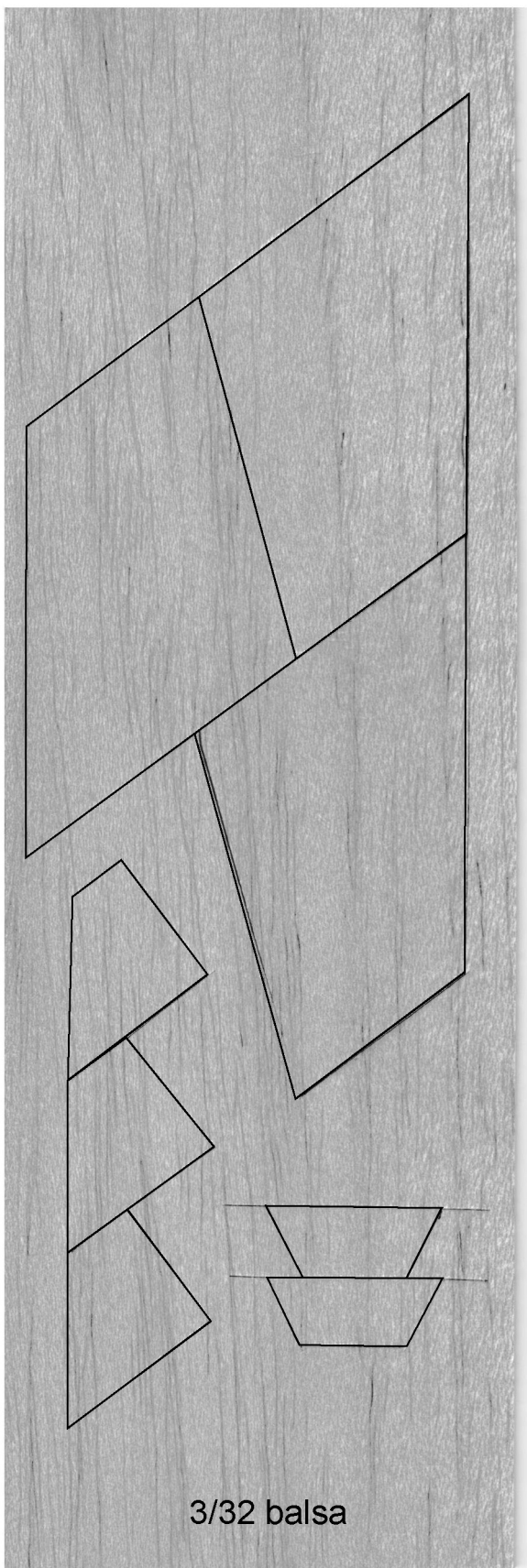

3/32 balsa

1 Inch

1 Inch

1 Inch

1 Inch

HARPOON

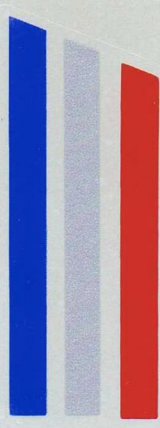

PN 37230

ESTES INDUSTRIES

1 Inch

1 Inch

1 Inch

1 Inch

1 Inch

1 Inch

1 Inch

1 Inch

HARPOON

FLYING MODEL ROCKET

SKILL LEVEL 1

1-Beginner 2-Intermediate 3-Craftsman
4-Advanced 5-Expert

- Unique Plastic Nose Cone
- Easy-To-Build
- Streamer Recovery
- Die-Cut Balsa Fins

Length: 13.75 in. (35 cm)

Dia: .976 in. (24.8 mm)

Weight: 1.3 oz. (37 g)

Engine Types:

A8-3 (First Flight)

B4-4, B6-4, C6-5

**FLIGHTS
UP TO
1000
FEET!**



A DAMON COMPANY

Recommended for ages 10 to adult. Adult supervision is suggested for those under 12 years of age when flying model rockets. This is a hobby kit requiring assembly. Engines, launch system, glue and finishing supplies are not included.



#1915

ESTES INDUSTRIES
PENROSE, CO 81240 USA

