





# INTERCEPTOR II

#1973

A DAMON COMPANY

ESTES INDUSTRIES  
1295 H STREET  
PENROSE, COLORADO 81240 USA

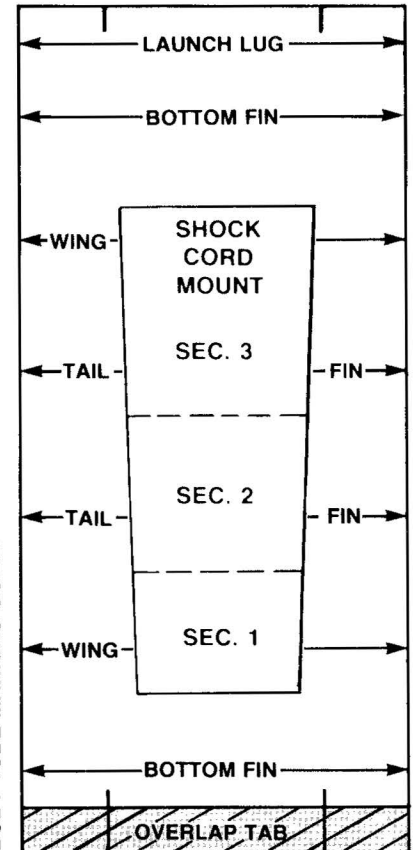
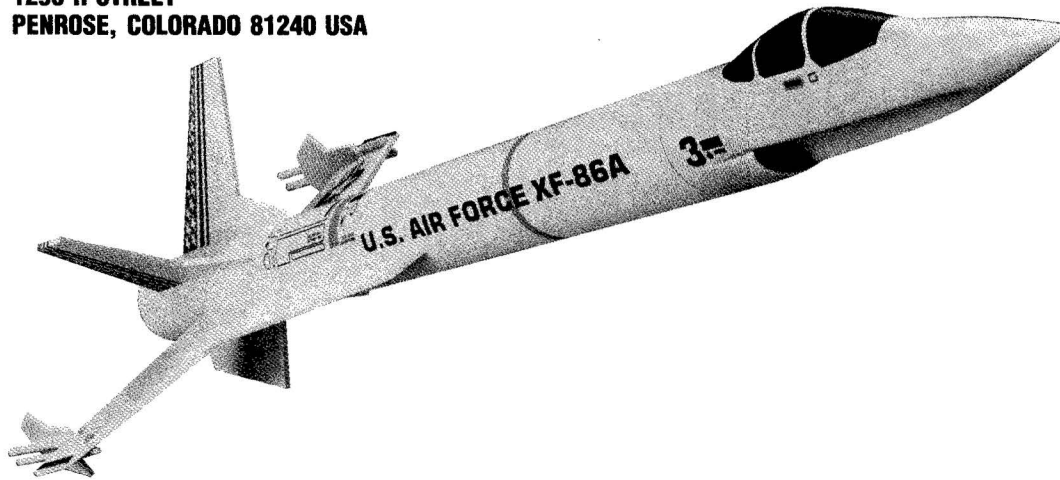

## PARTS AND SUPPLIES

Locate the parts shown below and lay them out on the table in front of you. In addition to the parts included in the kit you will also need:

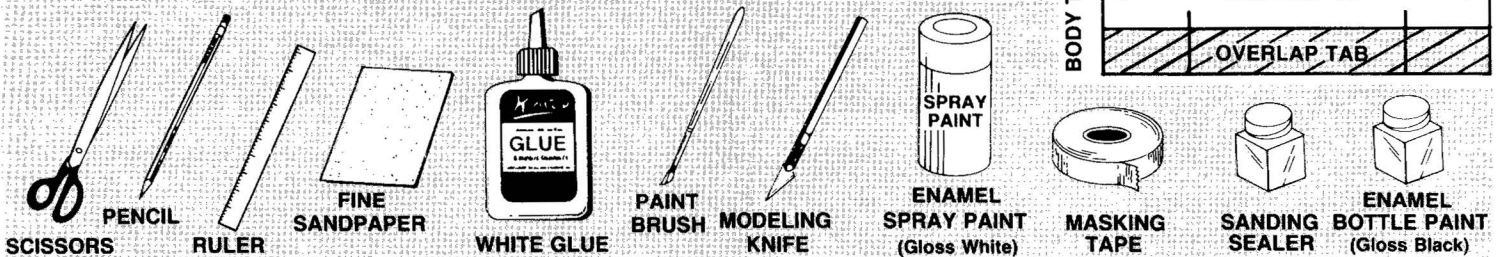

## ASSEMBLY TIP

Read all instructions before beginning work on your model. Make sure you have all parts and supplies. Test-fit all parts together before applying any glue. If any parts don't fit properly, sand as required for precision assembly.

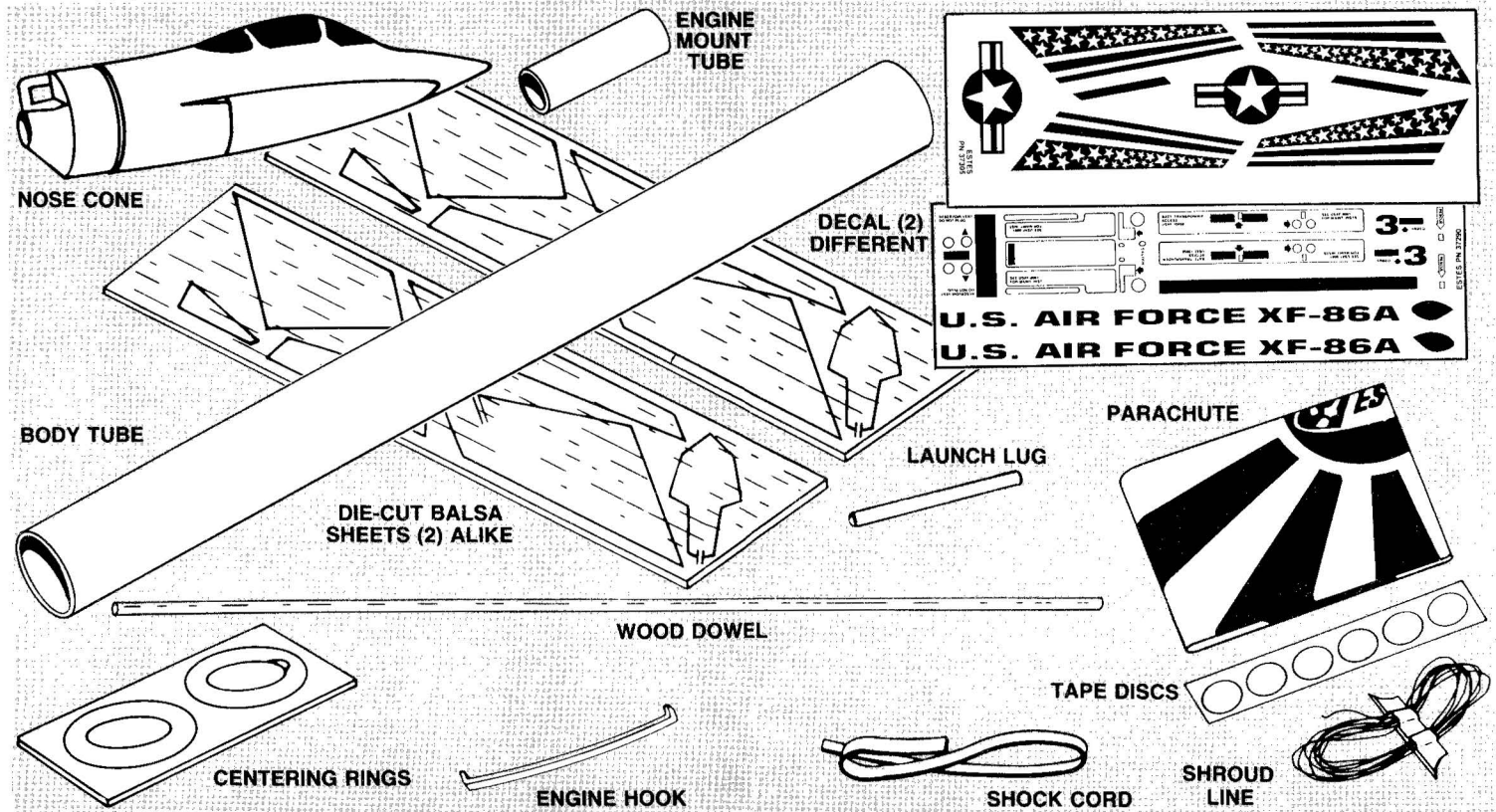

# ROCKET ASSEMBLY

- A. Mark engine mount tube 1 inch and 2½ inches from one end.
- B. Cut 1/8 inch long slit at 2½ inch mark.
- C. Insert one end of engine hook into slit.
- D. Wrap masking tape around assembly twice at 1 inch mark.
- E. Slide slotted adapter ring onto rear of tube and up to masking tape. Slot fits over engine hook. Glue both sides of ring/tube joint.
- F. Slide remaining ring over front of tube and down to end of engine hook. Glue both sides of ring/tube joint.

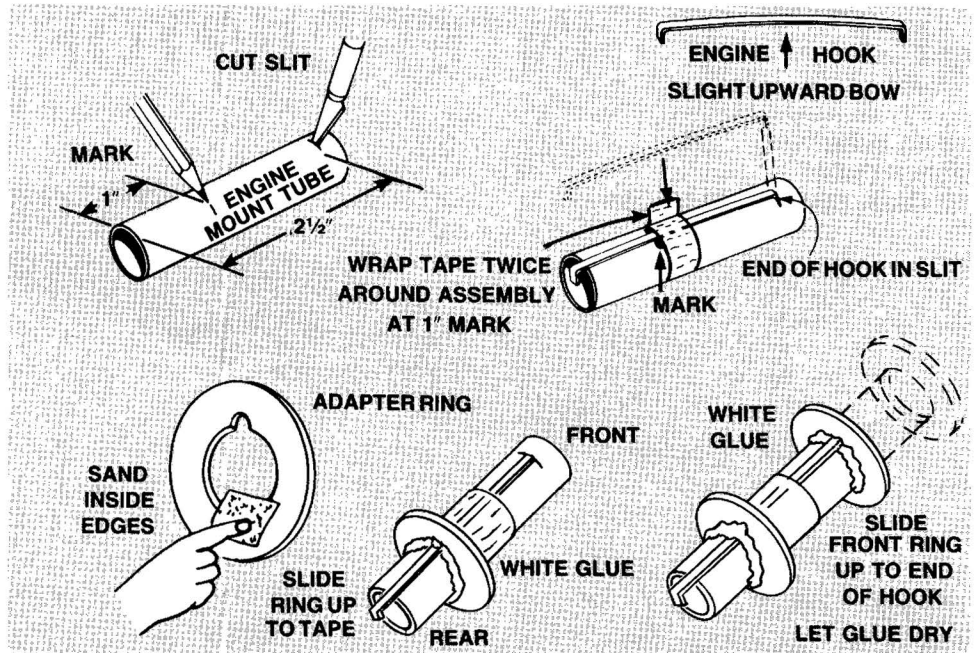

## 2

- A. Fine sand balsa die-cut sheets. Carefully remove fins by freeing edges with sharp knife.
- B. Stack alike fins together. Sand all edges smooth.

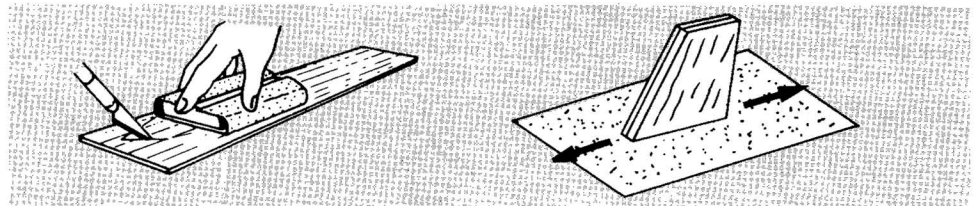

## 3

- A. Sort and identify the parts.
- B. Remove wood from slots in wings and wing fins.
- C. Assemble wings and tail fins over a piece of waxed paper, on a flat surface.
- D. Apply glue to edge of part to be joined. Press parts together. Use a ruler to make sure bottom edges of parts are straight. If not, adjust parts to make edge straight.
- E. Wipe away excess glue and let dry.

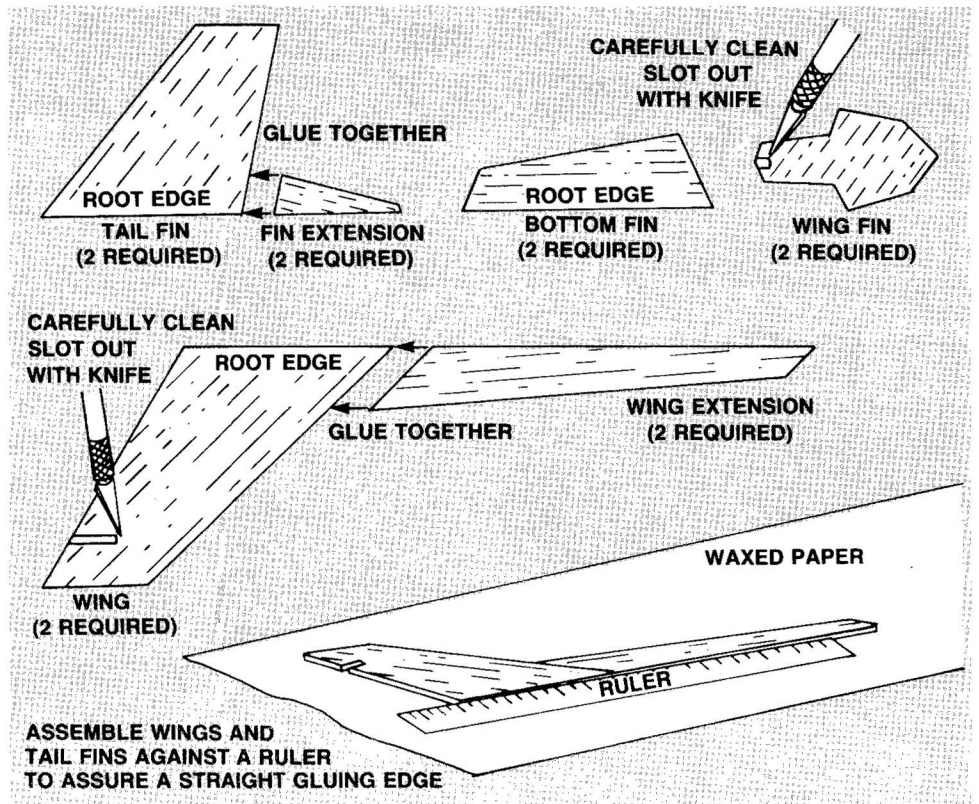

## 4

- A. Using a piece of scrap balsa, smear glue inside body tube 2 inches from one end.
- B. Push engine mount in until tube ends are even. Engine hook must extend from end of body tube.

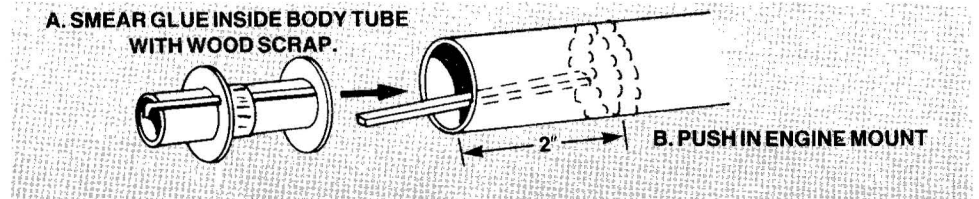



## 5

- A. Cut out tube marking guide from front of instructions.
- B. Wrap guide around the tube and tape. Mark tube at arrows. Remove guide and save.

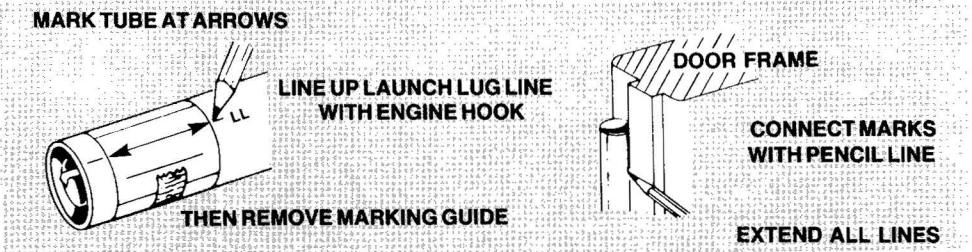

## 6

- A. Cut four 4½ inch long pieces from 18 inch long wood dowel.
- B. Apply glue to slots in wings and slide wing fins into place. Wipe excess glue from joints.
- C. Apply glue to each wood dowel at contact points of wing and fin. Position each dowel against wing fin and even with leading edge of wing. Attach two dowels per wing as shown.

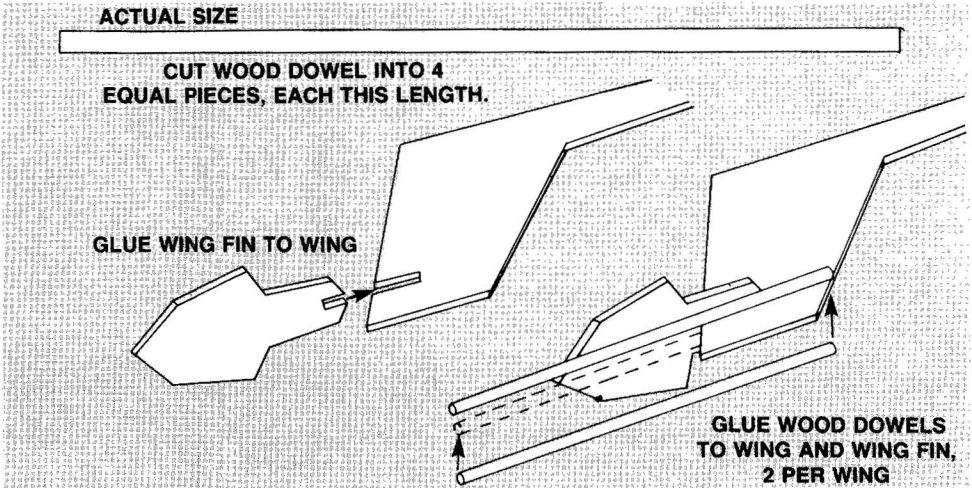

## 7

- A. Position tail fins on their alignment lines 1 inch from end of body tube. Let each dry several minutes before applying the next one.
- B. Position wings on their alignment lines 3 inches from end of body tube. Let dry before applying next one.
- C. Adjust fins and wings to project straight out from tube.
- D. Glue bottom fins to body on their alignment lines 1 inch from end of body tube. Adjust fins to project straight out from body tube. Let dry.
- E. Do not set rocket on fins or wings while glue is wet.

**FINS MUST BE ATTACHED CORRECTLY FOR STABLE FLIGHT!**

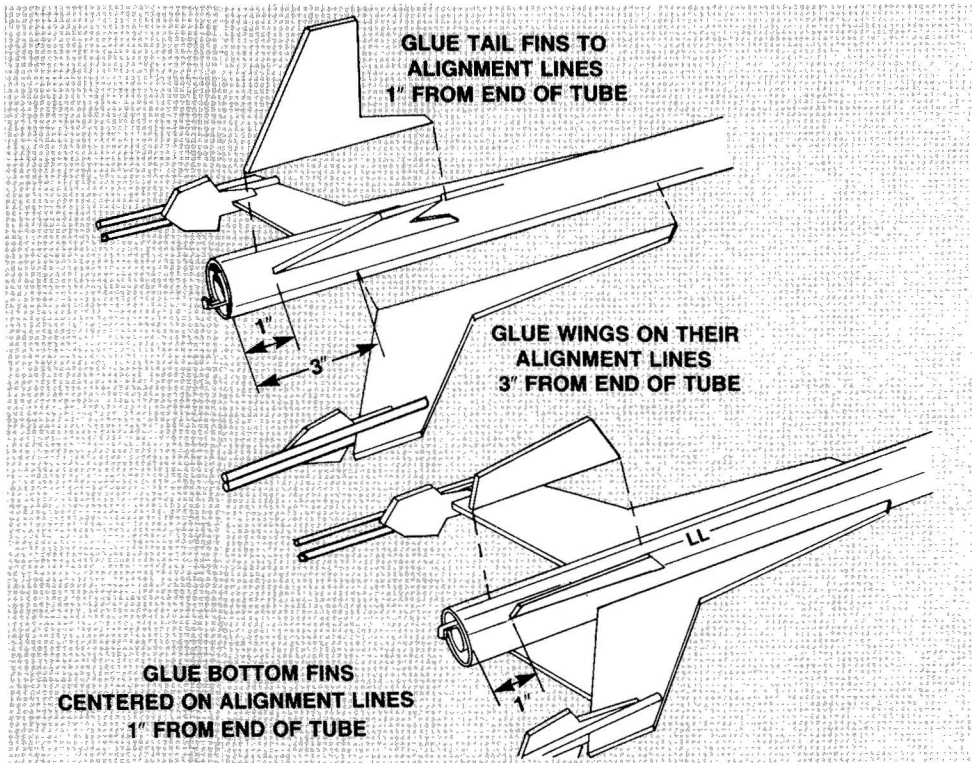

## 8

- A. Glue launch lug to rocket body on alignment line 6¾ inches from rear end of body tube.

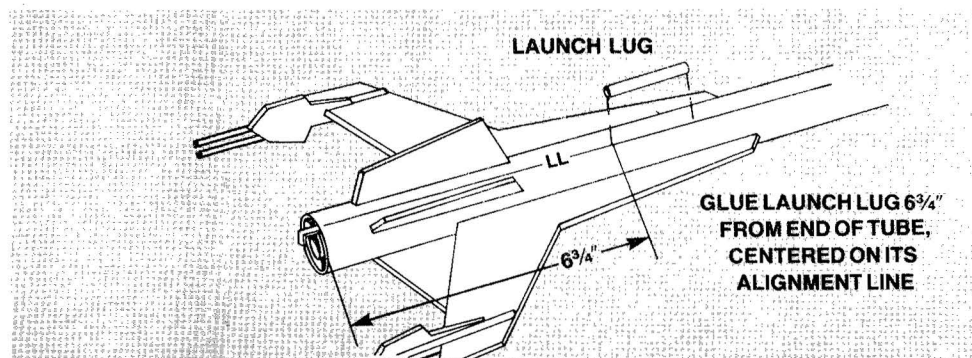

## 9

- Cut shock cord mount from tube marking guide.
- Crease on dotted lines by folding. Spread glue on section 1 and lay end of shock cord into glue. Fold over and apply glue to back of first section and exposed part of section 2. Lay shock cord as shown and fold mount over again.
- Clamp unit together with fingers until glue sets.

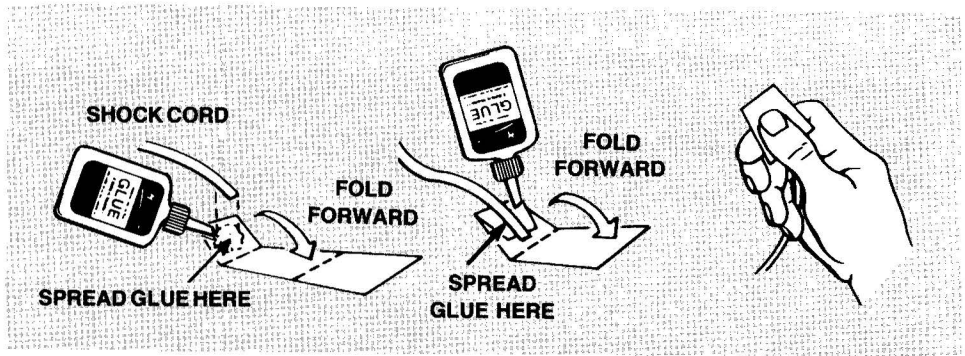

## 10

- Apply glue to inside front of large body tube to cover an area no less than 1 inch to 2 inches from end. The glued area should be same size as shock cord mount.
- Press mount firmly into glue as shown.
- Hold until glue sets.

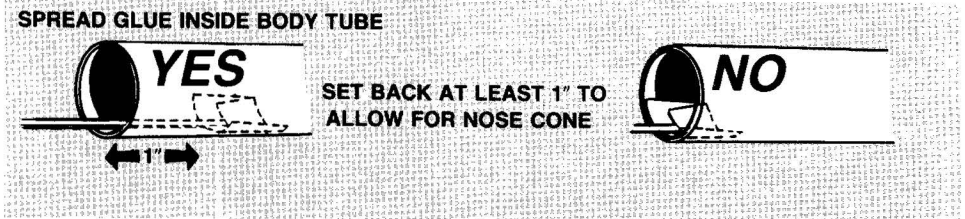

## 11

- Apply a glue reinforcement to each fin/body tube joint and each side of launch lug.
- Support rocket as shown until glue dries.

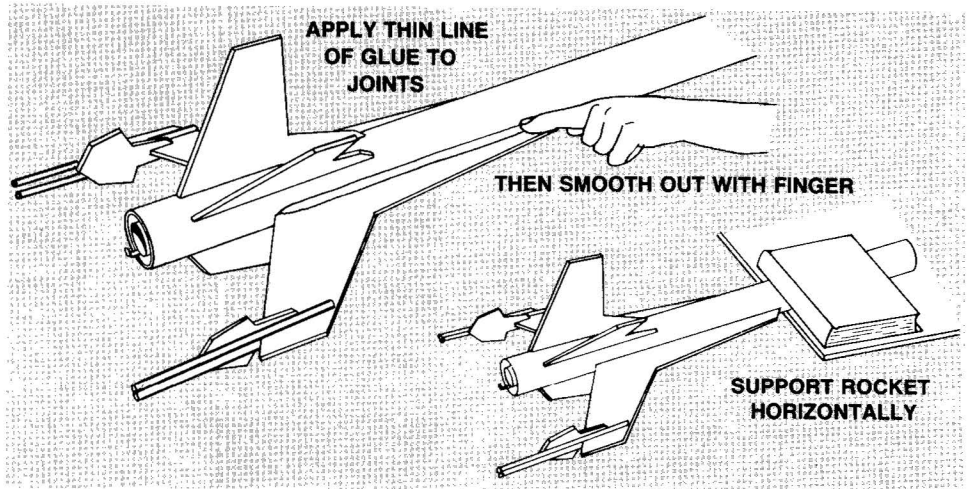

## 12

- Trim excess plastic from around sides of nose cone with a sharp knife. Also remove any excess plastic from inside molded eyelet.
- Wipe nose cone with damp cloth to remove oil and dirt.

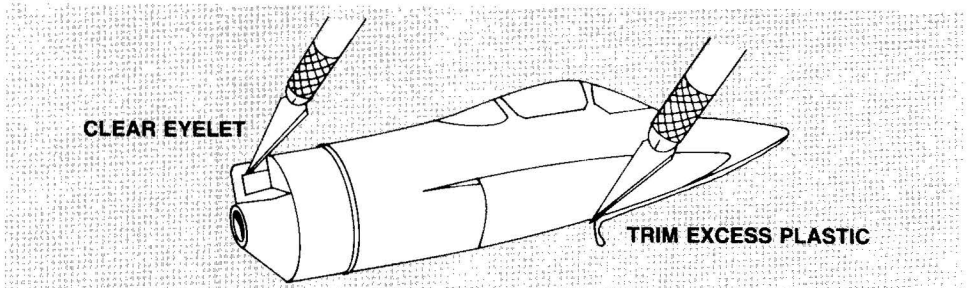

## 13

- Cut out parachute on edge lines.
- Cut three 36 inch lengths of shroud line.
- Form small loops with shroud line ends and press onto sticky side of tape discs.
- Attach tape discs with line ends to top of parachute as shown.
- Firmly press tape discs into place until both tape discs and parachute material are molded around shroud line loops.
- Pass shroud line loops through loop on nose cone. Pass parachute through loop ends and pull lines against the nose cone.
- Tie free end of shock cord to nose cone eyelet.

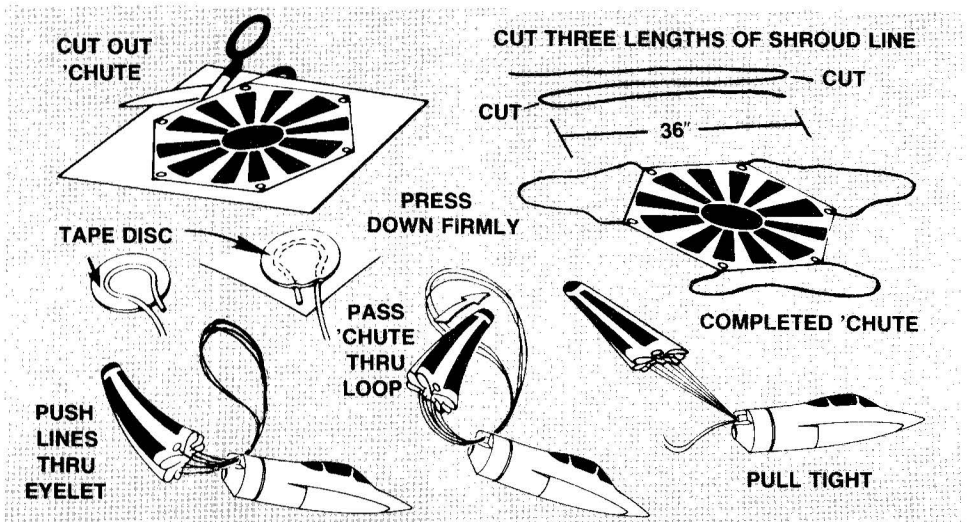

# FINISHING YOUR ROCKET

- A.** Apply sanding sealer to all wood parts with small brush. When sealer is dry, lightly sand all surfaces. Repeat sealing and sanding until balsa grain is filled and smooth. When sanding sealer and glue are completely dry, paint model with gloss white enamel spray paint. Follow instructions on spray can for best results. Let paint dry.
- B.** Mask and paint canopy of nose cone with gloss black paint. Allow paint to dry thoroughly before applying decals.
- C.** Apply decals in positions shown. Carefully trim clear from around decals. Dip each decal in lukewarm water for 20 seconds and hold until it uncurls. Slip decal off backing sheet and onto model. Blot away excess water and smooth out any wrinkles and air bubbles. Let decals dry overnight and apply a coat of clear spray paint to protect decals.

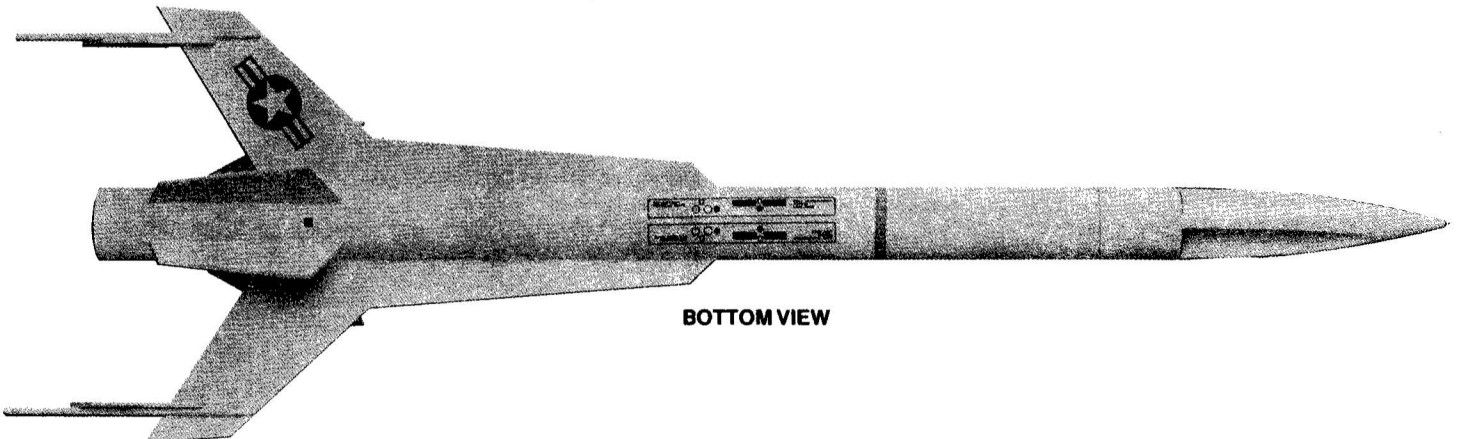
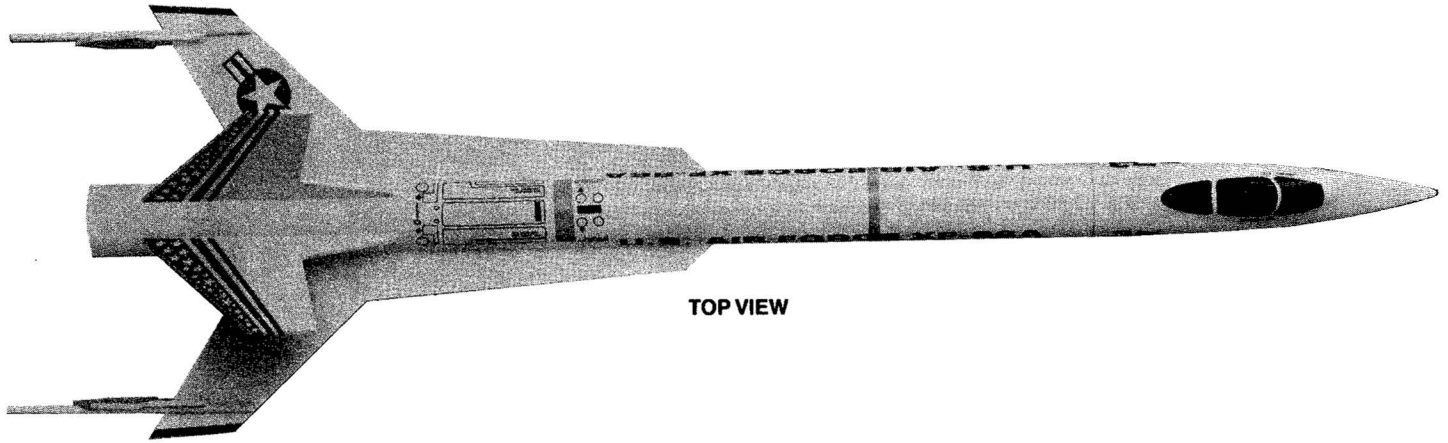
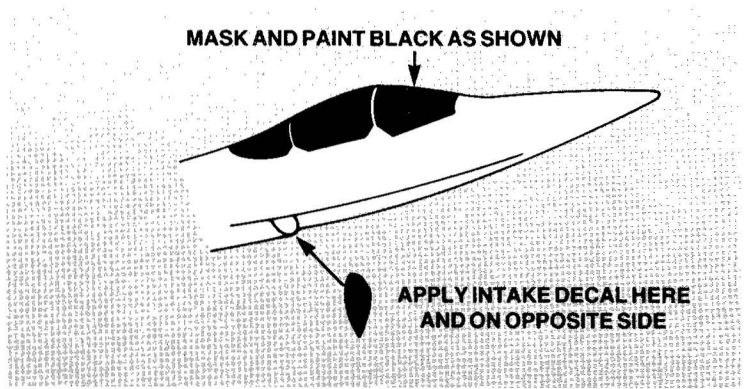



## ROCKET PREFLIGHT

CRUMPLE AND INSERT 3 SQUARES OF RECOVERY WADDING

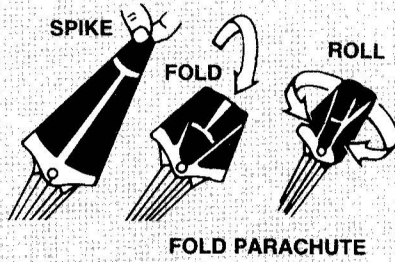
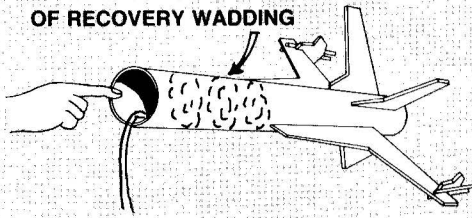

WRAP LINES LOOSELY AROUND 'CHUTE

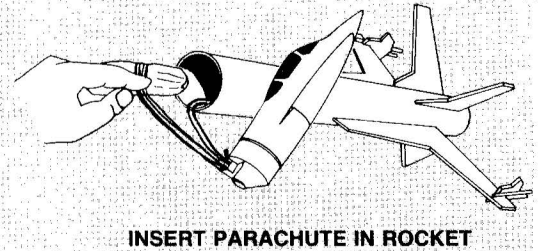

INSERT PARACHUTE IN ROCKET

## PREPARE ENGINE

SEPARATE THE IGNITERS

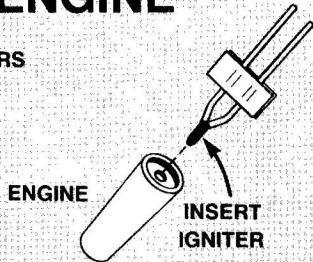
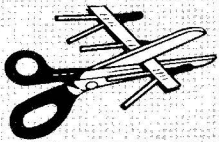

IGNITER TIP MUST TOUCH PROPELLANT DEEP INSIDE NOZZLE OPENING

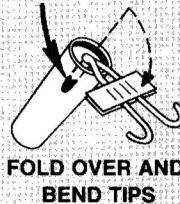

APPLY AND FIRMLY PRESS TAPE DISC OR MASKING TAPE IN PLACE

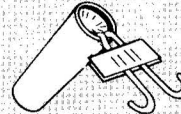

HOOK MUST LATCH OVER END OF ENGINE

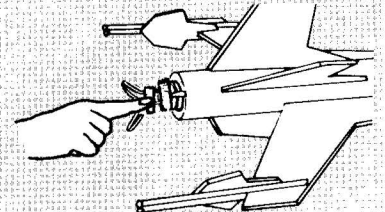

INSTALL ENGINE IN ROCKET

## LAUNCH SUPPLIES

To launch your rocket you will need the following items:

- An Estes model rocket launching system
- Estes Parachute Recovery Wadding (No. 2274)
- Recommended Engines: A8-3, B4-4, B6-4, B8-5, C6-3, C6-5

Use an B4-4 engine for your first flight to become familiar with your rocket's flight pattern.

## FLYING YOUR ROCKET

Choose a large field away from power lines, tall trees, and low flying aircraft. Try to find a field at least 250 feet square. The larger the launch area, the better your chance of recovering your rocket. Football fields and playgrounds are great.

Launch area must be free of dry weeds and brown grass.

Launch only during calm weather with little or no wind and good visibility.

Don't leave parachute packed more than a minute or so before launch during cold weather [colder than 40° Fahrenheit (4° Celsius)]

## MISFIRES

Failure of the rocket engine to function properly is nearly always caused by a failure to install the igniter correctly. This failure permits the igniter to heat and burn into two pieces without igniting the engine.

## FOR YOUR SAFETY AND ENJOYMENT

Always follow the NAR-HIA\* MODEL ROCKETRY SAFETY CODE while participating in any model rocketry activities.

\*National Association of Rocketry-The Hobby Industry of America

## COUNTDOWN AND LAUNCH

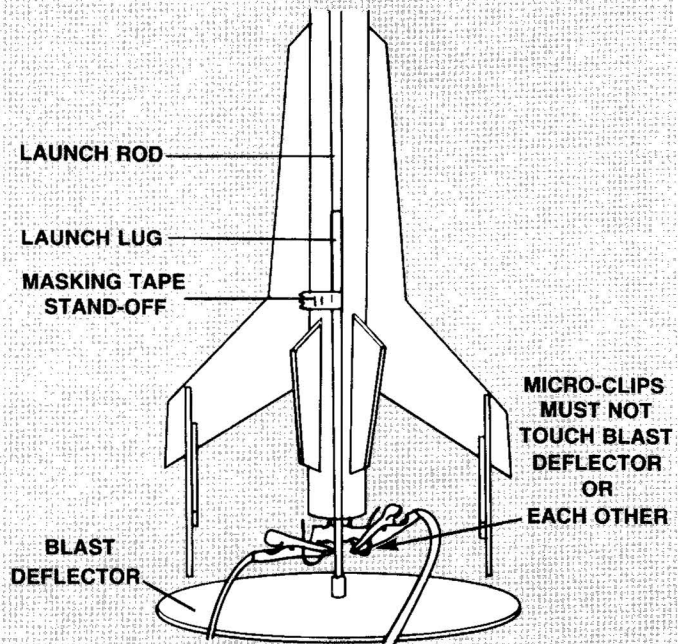

- 5 REMOVE SAFETY KEY to disarm the launch controller.
- 4 Remove safety cap and slide launch lug over launch rod to place rocket on launch pad. Make sure the rocket slides freely on the launch rod.
- 3 Attach micro-clips to the igniter wires. Arrange the clips so they do not touch each other or the metal blast deflector. Attach clips as close to protective tape on igniter as possible.
- 2 Move back from your rocket as far as launch wire will permit (at least 15 feet).
- 1 INSERT SAFETY KEY to arm the launch controller.

**LAUNCH!!!** PUSH AND HOLD LAUNCH BUTTON UNTIL ENGINE IGNITES

Remove safety key—Replace cap on rod.

# U.S. AIR FORCE XF-86A

# U.S. AIR FORCE XF-86A

ESTES PN 37290

RESCUE 

**3**  **WARNING** **ARMED**

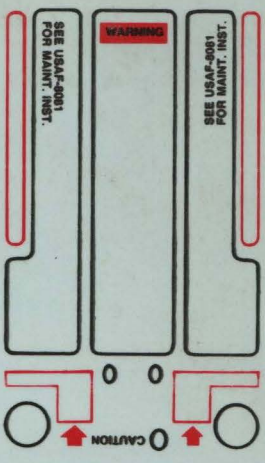
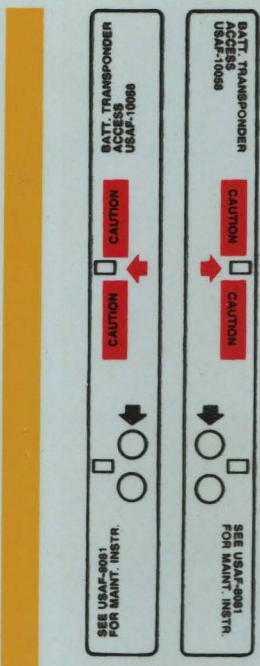









ESTES  
PN 37305



oot

**3/32"**  
**Balsa**  
**Make 2**



## Estes #1973 - Interceptor II

### Parts and Dimensions:

Quantity	Description	Type	Part #	Size	Other
1	Nose Cone	PNC-55IR	072054		Also used in #2068 Greyhawk, #2133 Astrosat LSX, #2183 Shuttle Xpress
1	Body Tube	BT-55	030382	18.00"	
1	Body Tube	BT-20J	030326	2.75"	
1	Engine Holder	EH-2	003141	2.8"	Old style, no thumb tab
2	Ring Adapters	RA-2055	003112		
2	Balsa Sheet	BFS-30L	003170	3/32" x 3" x 2"	2 die cut sheets are the same
1	Wood Dowel	WD-1	032056	3/32" x 18"	
1	Launch Lug	LL-2B	002323	1/8" x 2 3/8"	
1	Shock Cord	SC-1B	085734	1/8" x 12"	
1	Parachute	PK-18	002266	18"	
3	Shroud Line	SLT-1	038265	36"	
6	Tape Discs	TD-1	002295	3/4" Dia.	
1	Decal	N/A	037290		Air Force Panels & Markings
1	Decal	N/A	037305		Stars & Bars





# INTERCEPTOR II

## FLYING MODEL ROCKET

...with a...  
...the...  
...the...  
...the...  
...the...  
...the...  
...the...  
...the...



...the...  
...the...  
...the...  
...the...  
...the...  
...the...  
...the...  
...the...

