





A DAMON COMPANY

# TRANSTAR CARRIER

#1982

ESTES INDUSTRIES  
1295 H STREET  
PENROSE, CO 81240 USA

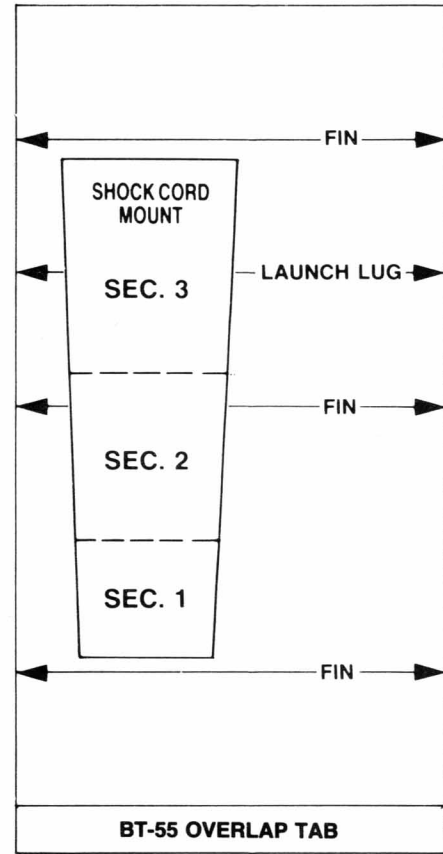

## ASSEMBLY TIP

Read all instructions before beginning work on your model. Make sure you have all parts and supplies. Test-fit all parts together before applying any glue. If any parts don't fit properly, sand as required for precision assembly.

## PARTS AND SUPPLIES

Locate the parts shown below and lay them out on the table in front of you. In addition to the parts included in the kit you will also need:

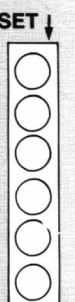
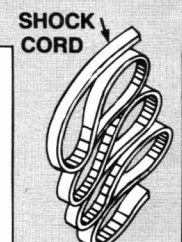
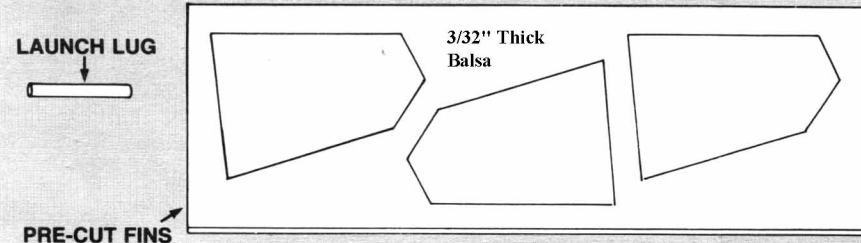
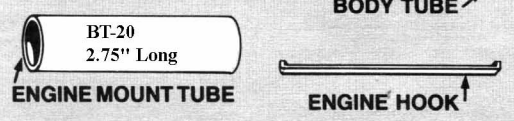
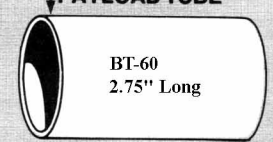
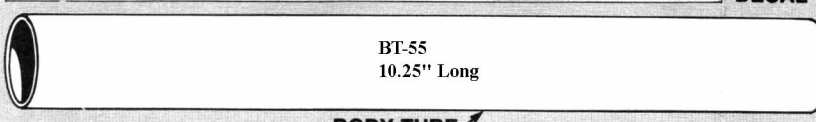
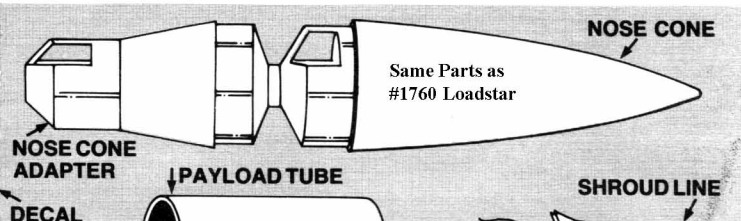
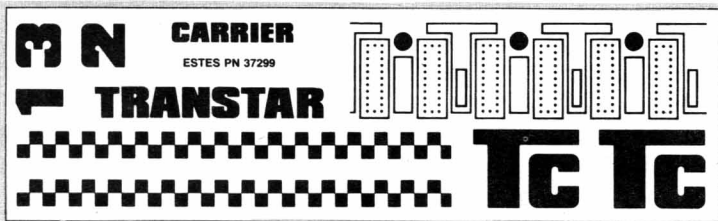

# ROCKET ASSEMBLY

**1**

- Mark engine mount tube 1 inch and 2½ inches from one end and then cut 1/8 inch long slit at 2½ inch mark.
- Insert one end of engine hook into slit.
- Slide centering ring (without notch) onto front of tube to 1 inch mark and glue both sides of ring/tube joint.
- Apply glue around front of tube and slide remaining adapter ring into place as shown. Apply glue to both sides of ring/tube joint.

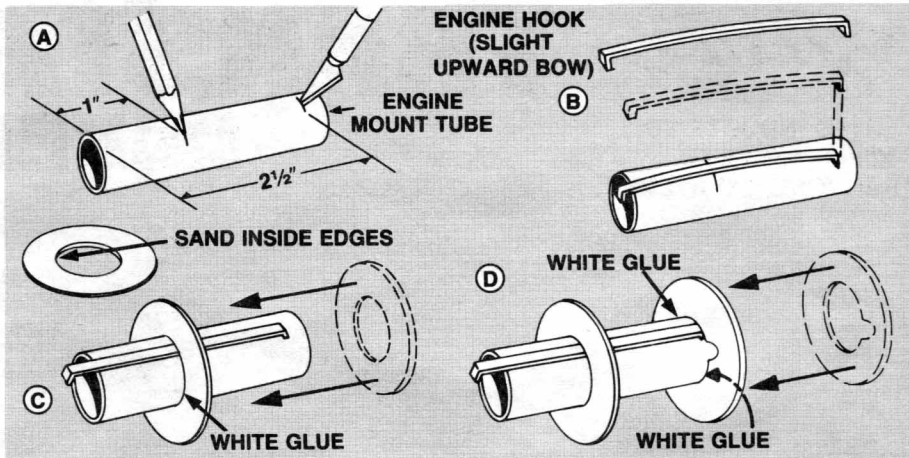

**2**

- Fine sand balsa pre-cut sheet. Carefully remove fins by freeing edges with sharp knife.
- Stack fins together. Sand all edges smooth.

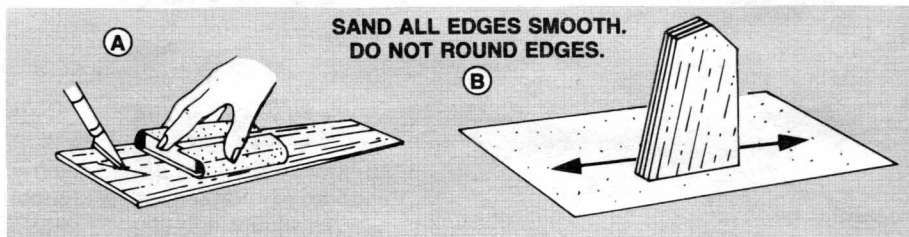

**3**

- Use a small, thin piece of scrap balsa (save large areas of scrap for Step 6.) to apply glue inside of body tube 1½ inch from one end.
- Push engine mount in until tube ends are even.

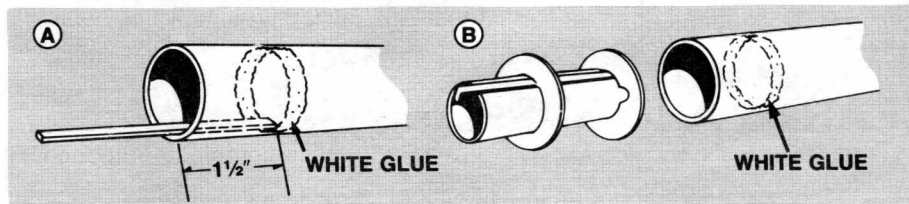

**4**

- Cut out tube marking guide from front of instructions and wrap guide around the tube (secure with tape.). Mark tube at arrows and remove guide and save.
- Draw straight lines connecting each pair of marks. Extend launch lug line full length of tube.

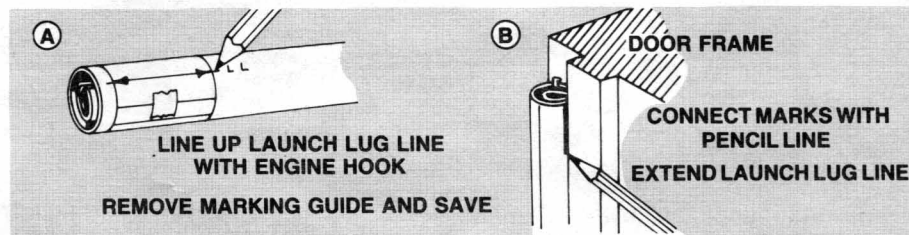

**5**

- Position and glue fins, one at a time, on alignment lines. See side view illustration for leading edge of fin. Let each dry several minutes before applying the next fin. For proper fin alignment, the fins should be in the position shown in illustration "YES" as seen from rear of rocket.

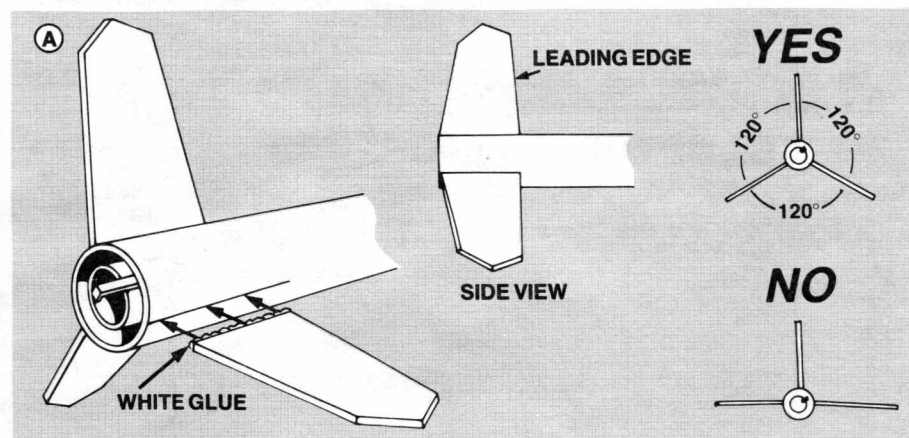

**6**

- Using template from back of panel, cut out two launch lug stand-offs from scrap balsa.
- Cut launch lug exactly in half giving two sections 5/8 inch each in length. Glue launch lug pieces to top of balsa stand-offs as shown.
- Glue complete stand-offs to launch lug alignment line as shown.

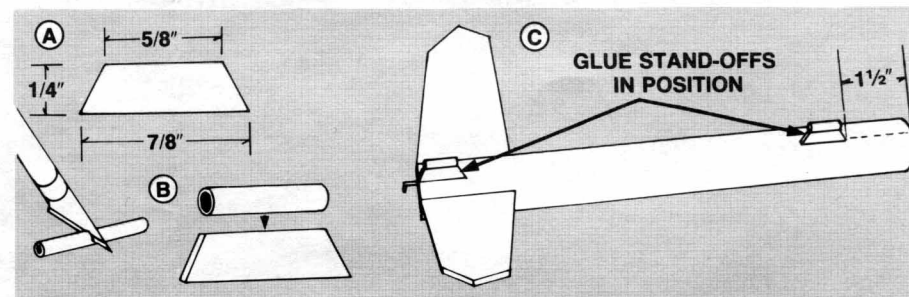

# 7

- A. Cut shock cord mount from tube marking guide. Crease on dotted lines by folding. Spread glue on section 1 and lay end of shock cord into glue. Fold over and apply glue to back of first section and exposed part of section 2. Lay shock cord as shown and fold mount over again.
- B. Clamp unit together with fingers until glue sets.

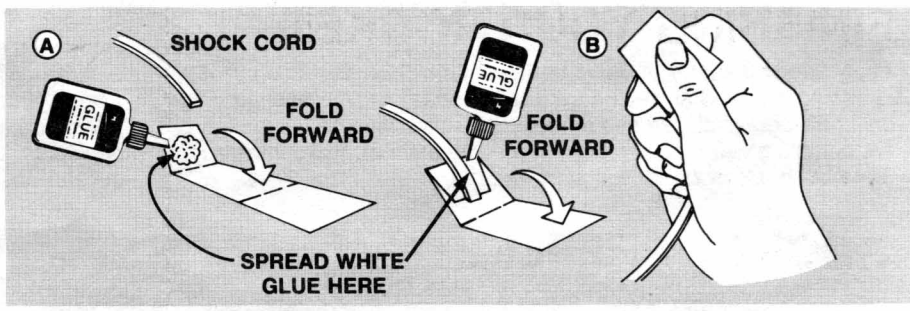

# 8

- A. Apply glue inside front of body tube to cover an area no less than 1 inch to 2 inches from end. The glued area should be same size as shock cord mount.
- B. Press mount firmly into glue as shown.
- C. Hold until glue sets.

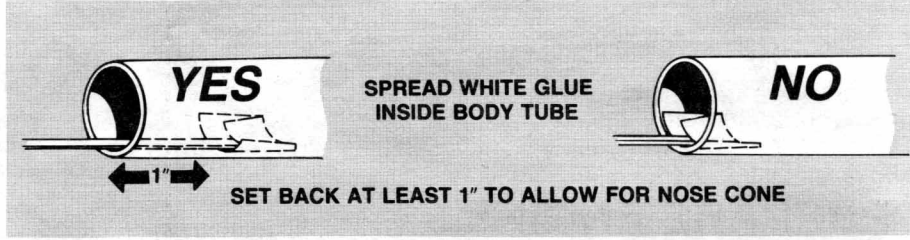

# 9

- A. Apply a glue reinforcement to each fin/body tube joint and each side of launch lugs.
- B. Support rocket as shown until glue dries.

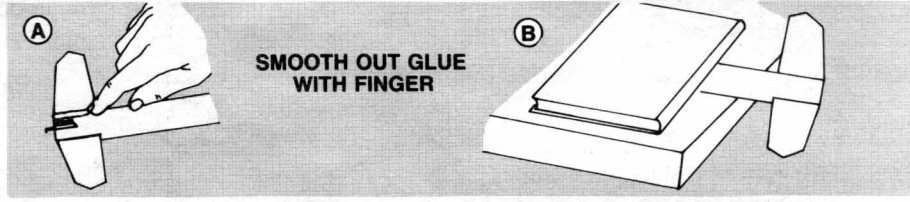

# 10

- A. Separate nose cone from nose cone adapter by sawing or cutting where indicated in Figure A.
- B. Apply a liberal amount of plastic cement to inside edge of payload tube 1/2 inch from end. Insert adapter with a twisting motion until it is seated against payload tube end.

### OPTIONAL

If you should choose to have the payload section carry small cargo, apply one layer of tape around nose cone section that fits into payload tube. The nose cone should fit snugly into payload tube. Should you elect not to carry cargo, cement the nose cone into the payload tube using the same procedure used in securing the adapter.

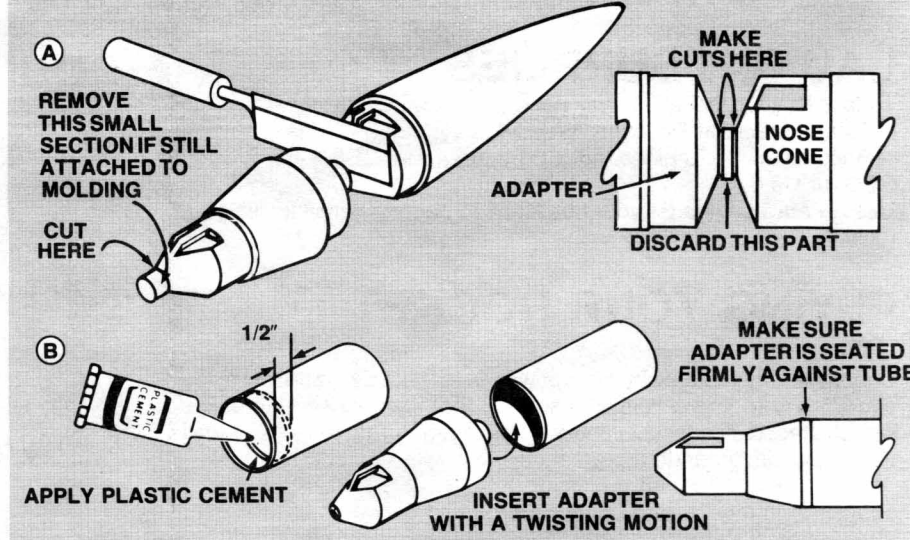

# 11

- A. Cut out parachute on edge lines.
- B. Cut three 23 inch lengths of shroud line.
- C. Form small loops with shroud line ends and press onto sticky side of tape discs. Attach tape discs with line ends to top of parachute as shown.
- D. Firmly press tape discs into place until both tape discs and parachute material are molded around shroud line loops.
- E. Pass shroud line loops through eyelet on payload adapter. Pass parachute through loop ends and pull lines against the payload adapter.
- F. Tie free end of shock cord to eyelet on payload adapter.

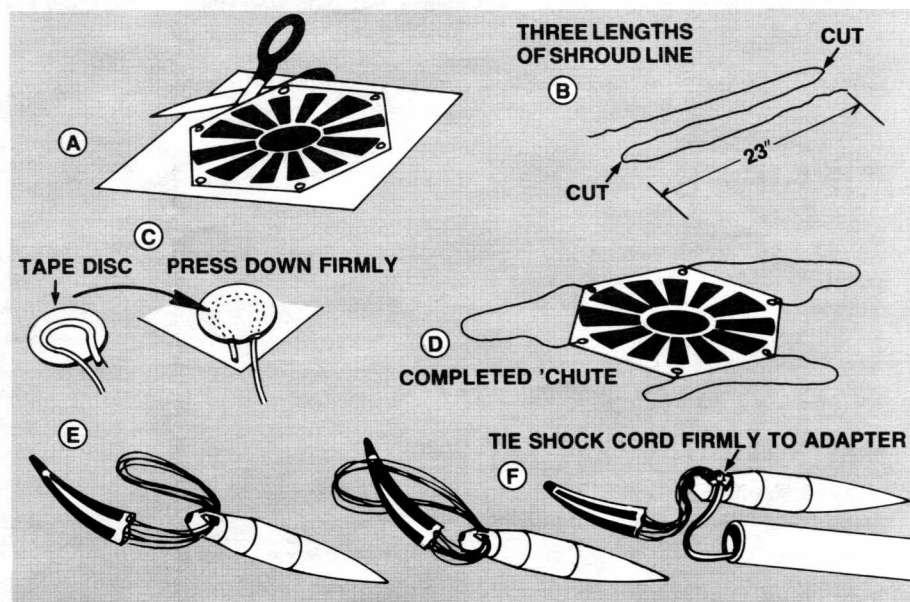

# FINISHING YOUR ROCKET

Apply sanding sealer to wood parts with small brush. When sealer is dry, lightly sand all sealed surfaces. Repeat sealing and sanding until balsa grain is filled and smooth. When sanding sealer and glue are completely dry, paint model with spray enamel. **Follow instructions on back of panel for painting.**

**Decal:** To apply decals, cut each out, dip in lukewarm water for 20 seconds, and hold until it uncurls. Refer to photograph on front page and/or on front of panel for decal placement. Slip decal off backing sheet and onto model. Blot away excess water. For best results, let decals dry overnight and apply a coat of clear spray paint to protect decals.

## ROCKET PREFLIGHT

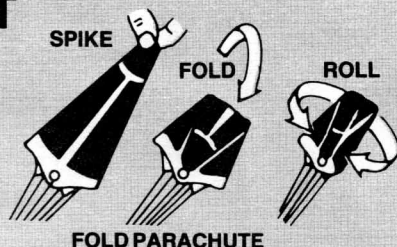
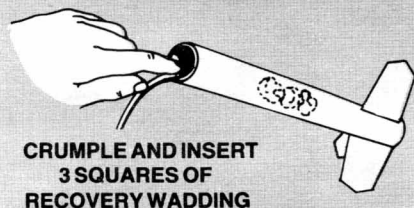

**WRAP LINES LOOSELY AROUND 'CHUTE**

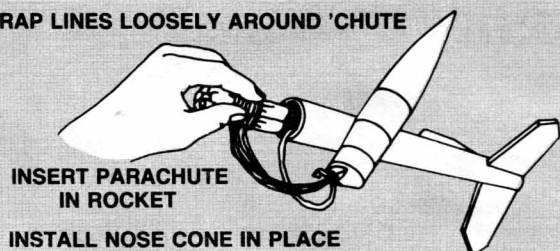

## PREPARE ENGINE

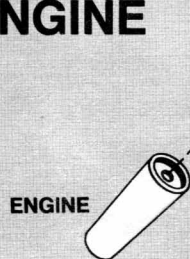
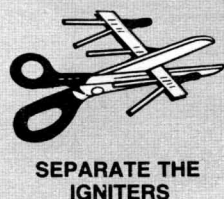

**IGNITER TIP MUST TOUCH PROPELLANT DEEP INSIDE NOZZLE OPENING**

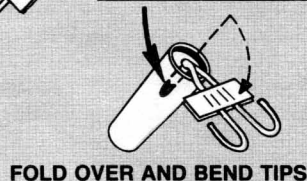

**APPLY AND FIRMLY PRESS MASKING TAPE OR TAPE DISC IN PLACE**

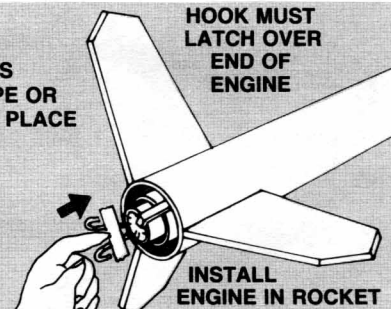

## LAUNCH SUPPLIES

To launch your rocket you will need the following items:  
—Estes Parachute Recovery Wadding (No. 2274)  
—Recommended Engines: A8-3, B4-2, B4-4, B6-2, B6-4, B8-5, C5-3, C6-3, or C6-5.  
Use an A8-3 engine for your first flight, to become familiar with your rocket's flight pattern.

## FLYING YOUR ROCKET

Choose a large field away from power lines, tall trees, and low flying aircraft. Try to find a field at least 250 feet square. The larger the launch area, the better your chance of recovering your rocket. Football fields and playgrounds are great.

Launch area must be free of dry weeds and brown grass.

Launch only during calm weather with little or no wind and good visibility.

Don't leave parachute packed more than a minute or so before launch during cold weather. [Colder than 40° Fahrenheit (4° Celsius)].

## MISFIRES

Failure of the rocket engine to function properly is nearly always caused by a failure to install the igniter correctly. This failure permits the igniter to heat and burn into two pieces without igniting the engine.

## FOR YOUR SAFETY AND ENJOYMENT

Always follow the NAR-HIA\* MODEL ROCKETRY SAFETY CODE while participating in any model rocketry activities.

\*National Association of Rocketry-The Hobby Industry of America

## COUNTDOWN AND LAUNCH

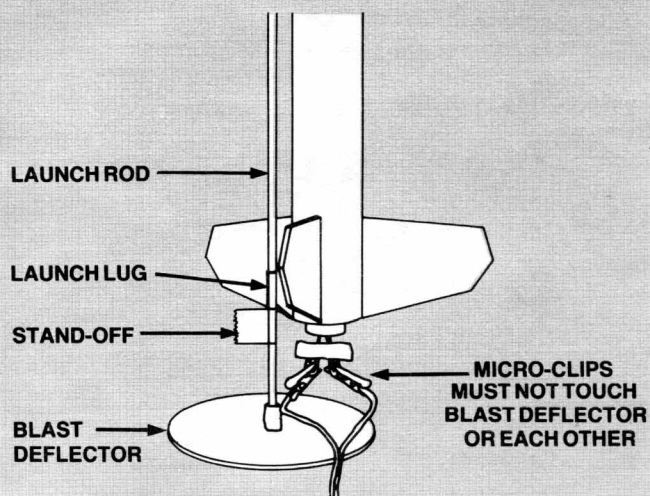

- ⑤ REMOVE SAFETY KEY to disarm the launch controller.
- ④ Remove safety cap and slide launch lugs over launch rod to place rocket on launch pad. Make sure the rocket slides freely on the launch rod.
- ③ Attach micro-clips to the igniter wires. Arrange the clips so they do not touch each other or the metal blast deflector. Attach clips as close to protective tape on igniter as possible.
- ② Move back from your rocket as far as launch wire will permit (at least 15 feet).
- ① INSERT SAFETY KEY to arm the launch controller.

**LAUNCH!!!** PUSH AND HOLD LAUNCH BUTTON UNTIL ENGINE IGNITES  
Remove safety key—Replace cap on rod.



**TEMPLATE FOR  
STAND-OFFS**

## STEP 6

Cut out template and then place on scrap balsa and trace around template. Using sharp knife, cut out tracing. You will need two stand-offs.

## PAINTING INSTRUCTIONS

**GLOSSY WHITE**

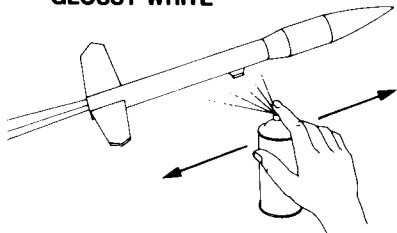

**1**

Roll newspaper and insert into engine mount to support rocket. Paint entire rocket glossy white. Let dry overnight.

**RED**

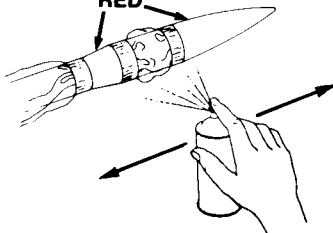

**2**

Using masking tape and paper or plastic to cover areas to remain white. Paint nose cone and adapter bright red.

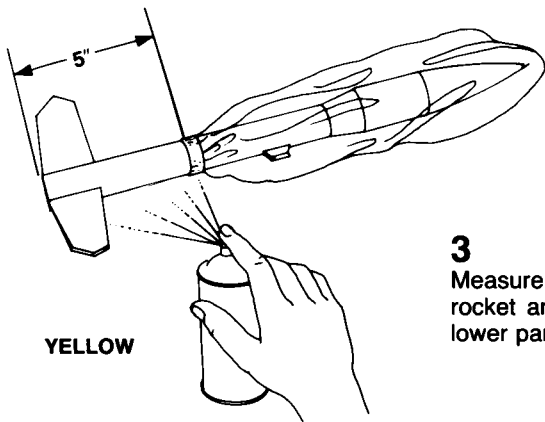

**YELLOW**

**3**

Measure 5 inches up from end of rocket and mask off. Spray fins and lower part of body tube bright yellow.

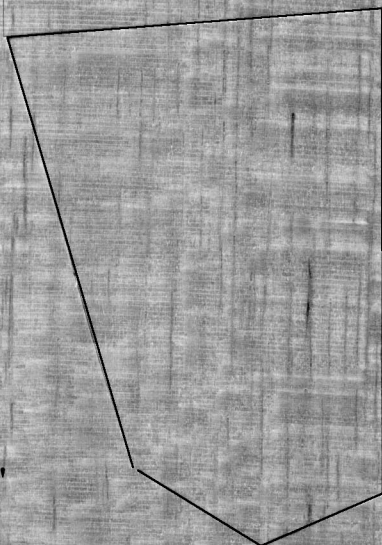
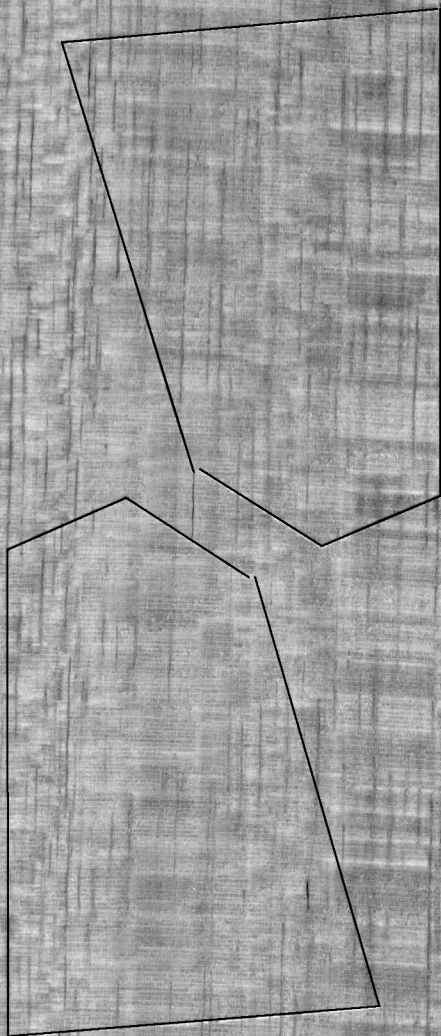
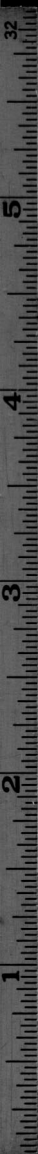

3/32"

**32**

**CARRIER**

ESTES PN 37299

**1**

**TRANSTAR**

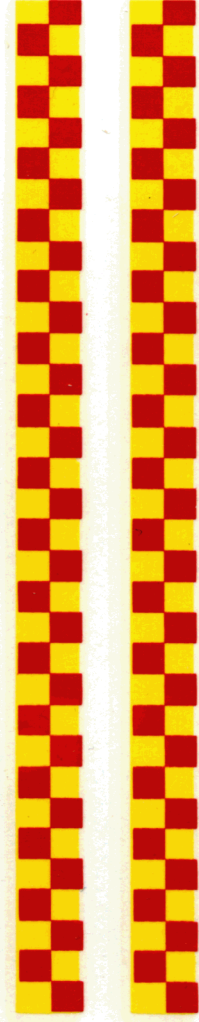
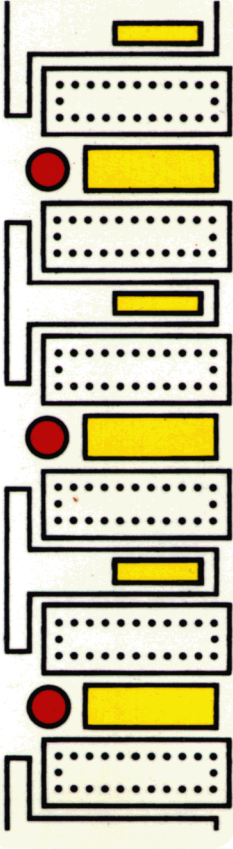

**TC**

**TC**



# TRANSTAR CARRIER

## FLYING MODEL ROCKET

**SKILL LEVEL 1**

### ■ CARGO BAY

- Quick-Release Engine Mount
- Plastic Nose Cone
- Die-Cut Balsa Fins
- 12" Parachute

Length: 18.25 in. (46.5 cm)

Wt.: 1.50 lb. (680 g)

Payload Wt.: 1.00 lb. (450 g)

Wingspan: 1.2 in. (30.5 mm)

### Recommended Engines:

9A, 9B, 9C, 9D

10A, 10B, 10C

11A, 11B, 11C

12A, 12B, 12C

13A, 13B, 13C

FLY  
PAYLOADS  
TO  
750 FEET!

Place a model engine in the engine bay, attach the engine mount, and you're ready to fly! Includes a 12" parachute and a 12" parachute.

**ESTES**

ESTES INDUSTRIES  
INCORPORATED, 100 STEVENSON

#1962

