





ESTES INDUSTRIES
1295 H Street
Penrose, CO 81240

RAVEN^{T.M.}

FLYING MODEL ROCKET
#2029

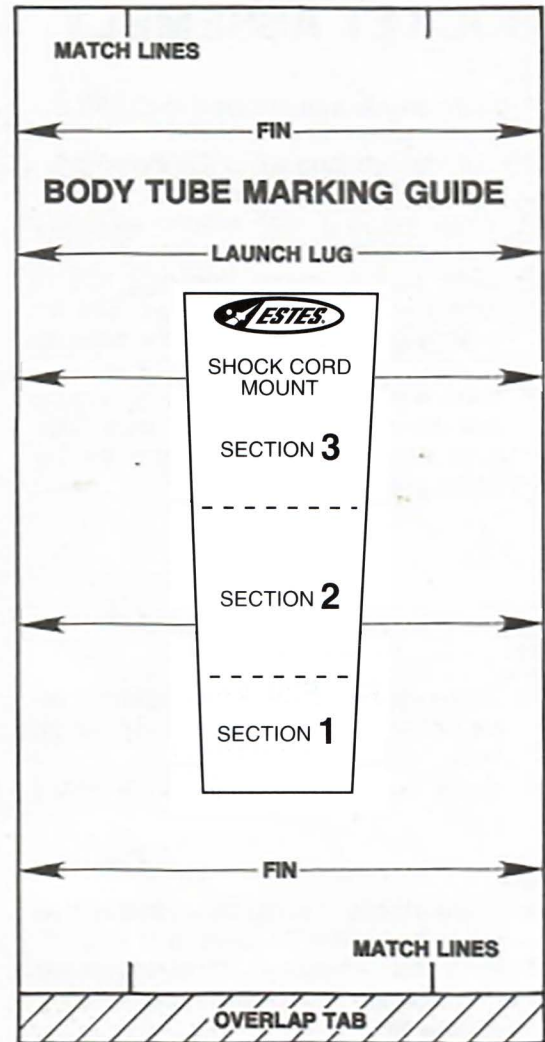

ASSEMBLY TIP

Read all instructions before beginning work on your model. Make sure you have all parts and supplies. Test-fit all parts together before applying any glue. If any parts don't fit properly, sand as required for precision assembly.

PARTS AND SUPPLIES

Locate the parts shown below and lay them out on the table in front of you. In addition to the parts included in the kit you will also need:

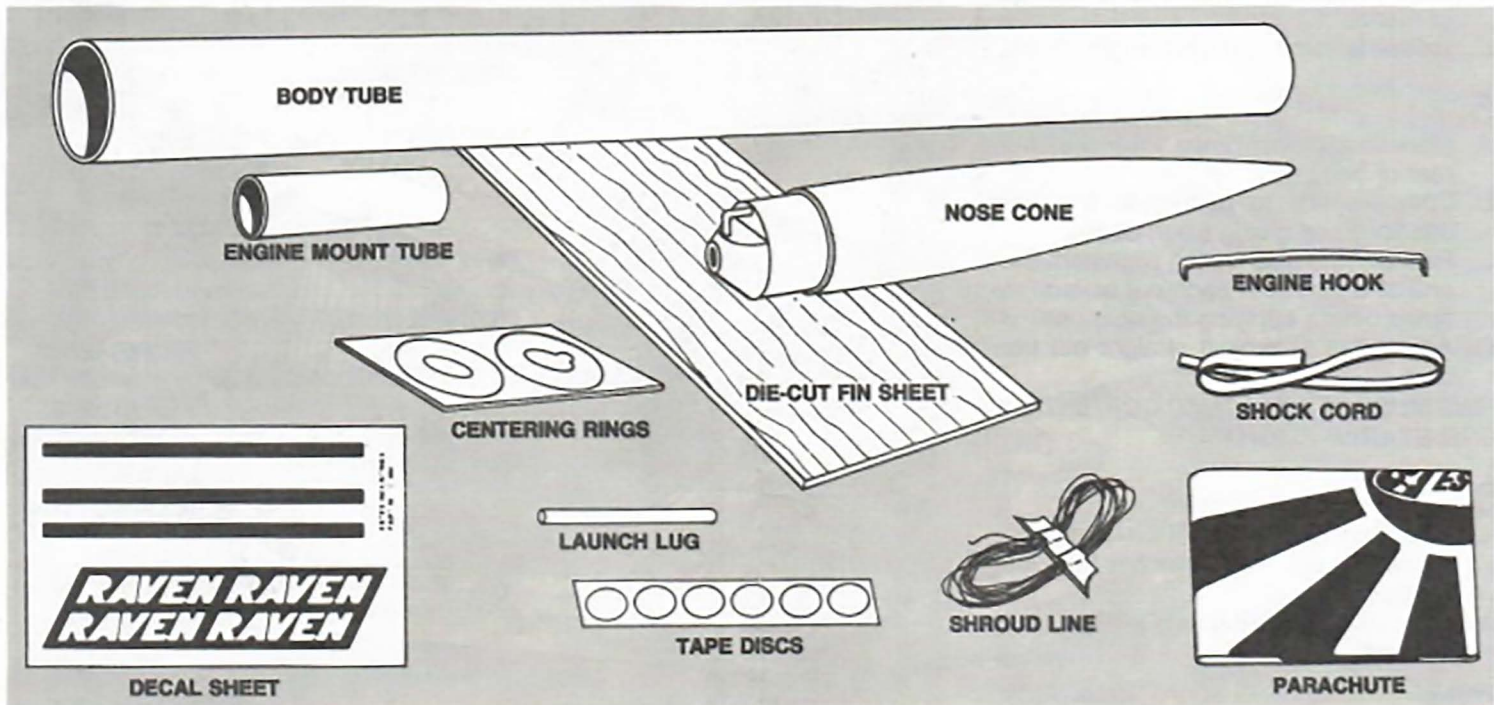

ROCKET ASSEMBLY

1.

- Mark engine mount tube 1 inch and 2½ inches from one end.
- Cut 1/8 inch long slit at 2½ inch mark.
- Insert one end of engine hook into slit.
- Wrap masking tape around assembly twice at 1 inch mark.
- Slide slotted adapter ring onto rear of tube and up to masking tape. Slot fits over engine hook. Glue both sides of ring/tube joint.
- Slide remaining ring over front of tube and down to end of engine hook. Glue both sides of tube joint. Set assembly aside to dry.

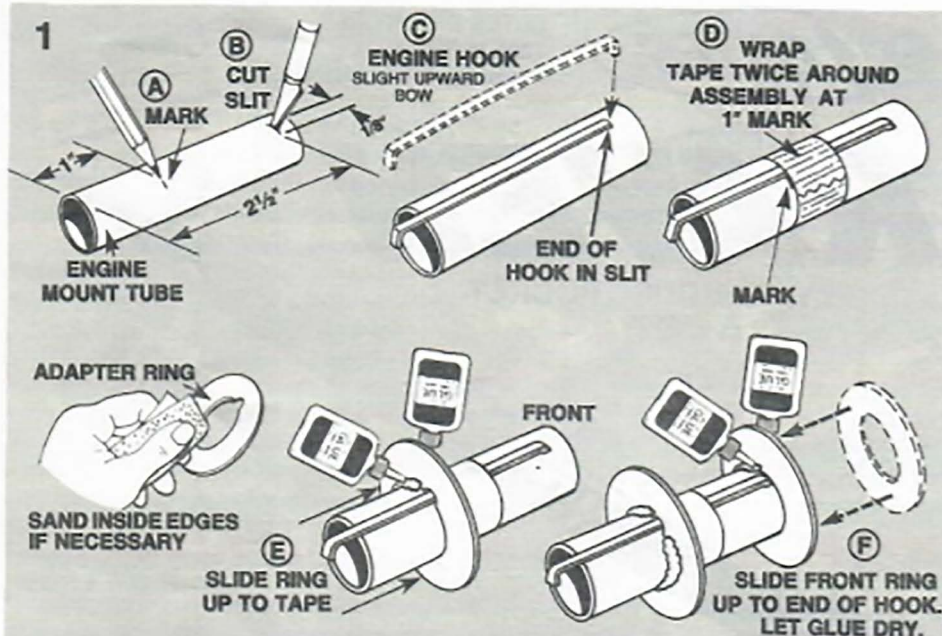

2.

- Fine-sand die-cut sheet. Carefully remove fins by freeing edges with sharp knife.
- Stack fins together. Sand all edges smooth.

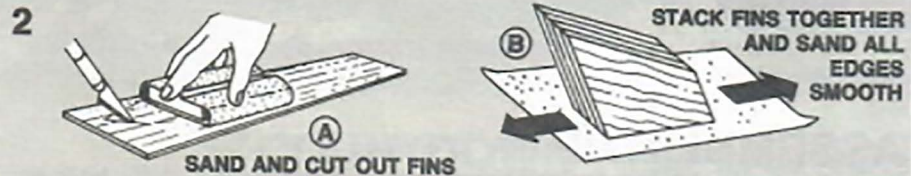

3.

- Using a piece of scrap balsa, smear glue inside body tube 2 inches from end.
- Push engine mount in until tube ends are even. Engine hook must extend from end of body tube.

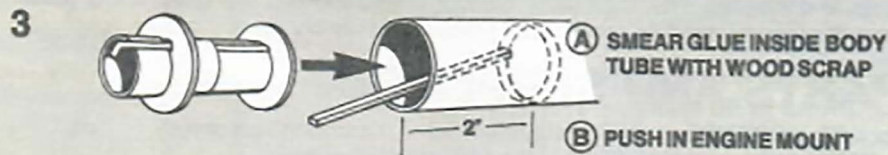

4.

- Cut out body tube marking guide from front of instructions.
- Wrap guide around the tube and tape. Mark tube at arrows. Remove guide.
- Draw straight lines connecting each pair of marks.
- Extend launch lug line full length of tube.

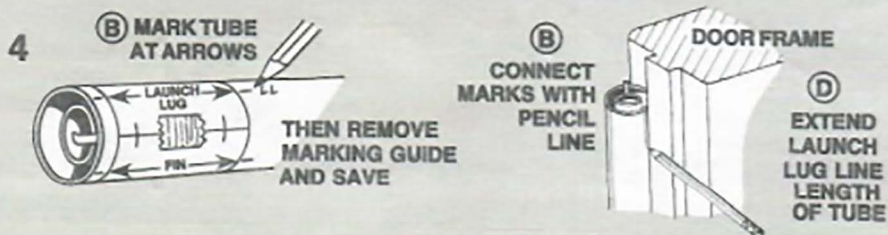

5.

- Mark fin alignment lines 1¼ inches from rear of body tube.
- Compare fins to pattern to find front (leading) and gluing (root) edges.
- Position and glue fins on alignment lines one at a time. Let each dry several minutes before applying the next one.
- Adjust fins to project straight out from tube.

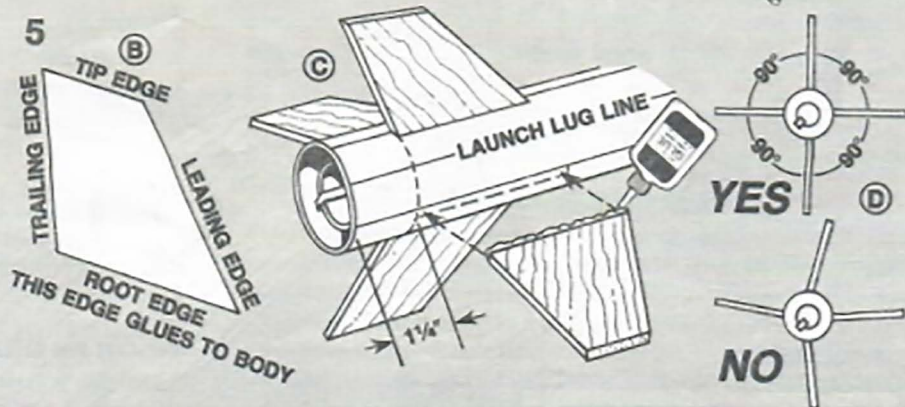

FINS MUST BE ATTACHED CORRECTLY FOR STABLE FLIGHT!

6.

- Glue launch lug straight on launch lug line with its rear edge 8 inches from rear of tube.
- Make sure launch lug runs straight along the tube.

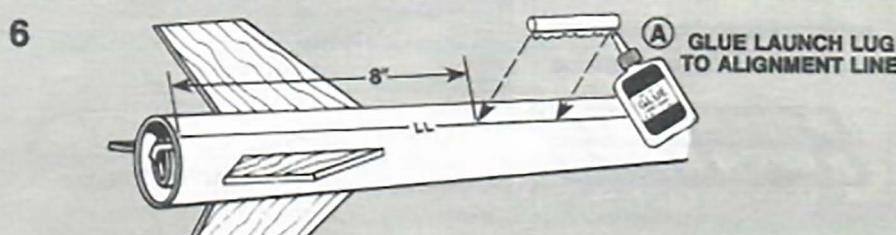

7.

- Cut shock cord mount from body tube marking guide.
- Crease on dotted lines by folding. Spread glue on section 1 and lay end of shock cord into glue. Fold over and apply glue to back of first section and exposed part of section 2. Lay shock cord as shown and fold mount over again.
- Clamp unit together with fingers until glue sets.

8.

- Apply glue to inside of front of body tube to cover an area no less than 1 inch to 2 inches from end. The glued area should be same size as shock cord mount.
- Press mount firmly into glue as shown.
- Hold until glue sets.

9.

- Apply a glue reinforcement to each fin/body tube joint and each side of launch lug.
- Support rocket as shown until glue dries.

10.

- Trim excess plastic from the sides of the nose cone and lightly sand the seams. Wash the nose cone in warm soapy water. Allow to dry thoroughly before painting.

11.

- Cut out parachute on edge lines.
- Cut three 23 inch lengths of shroud line.
- Form small loops with shroud line ends and press onto sticky side of tape discs.
- Attach tape discs with line ends to top of parachute as shown.
- Firmly press tape discs into place until both tape discs and parachute material are molded around shroud line loops.
- Pass shroud line loops through eyelet on nose cone. Pass parachute through loop ends and pull lines against the nose cone.
- Tie free end of shock cord to nose cone eyelet.

12.

- Apply sanding sealer to all wood parts with small brush.
- When sealer is dry, lightly sand all sealed surfaces.
- Repeat sealing and sanding until wood grain is filled and smooth.
- When sanding sealer and glue are completely dry, paint model with gloss light gray enamel.
- Follow instructions on spray can for best results.
- Let dry overnight. Mask off rocket and paint bottom section of rocket with gloss black enamel.
- Remove masking from rocket as soon as paint has set.

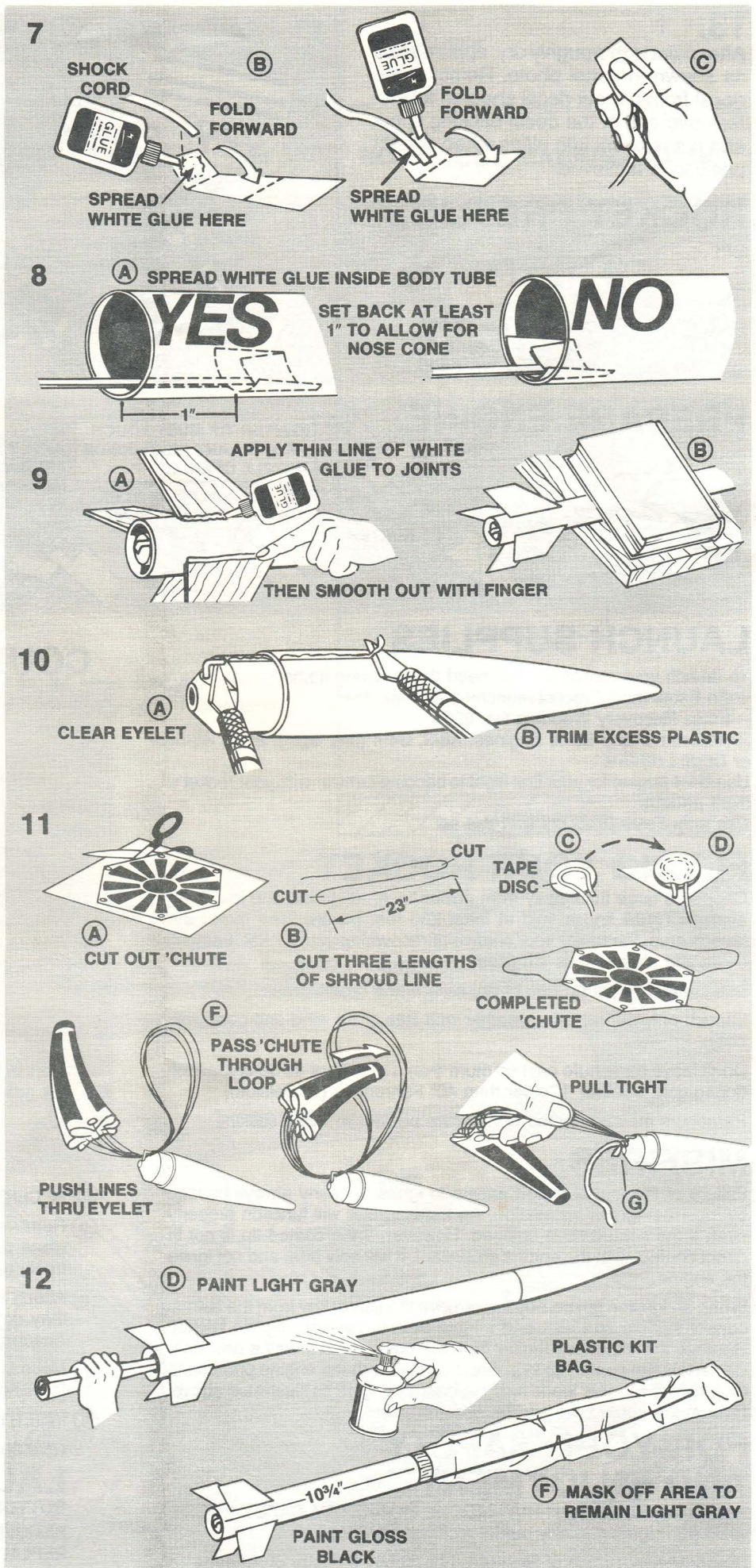

13.

After paint is thoroughly dry, apply decals as shown in panel photo. Remove one decal from die-cut decal sheet at a time. Remove any of the decal backing sheet and press decal into place when correct position is achieved.

13

CAREFULLY REMOVE DECALS FROM SHEET

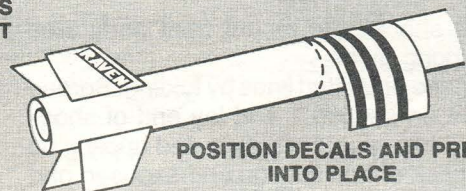

POSITION DECALS AND PRESS INTO PLACE

ROCKET PREFLIGHT



CRUMPLE AND INSERT 6 OR 8 SQUARES OF RECOVERY WADDING

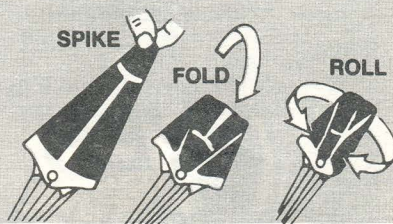

SPIKE

FOLD

ROLL

WRAP LINES LOOSELY AROUND 'CHUTE

INSERT PARACHUTE IN ROCKET

INSTALL NOSE CONE IN PLACE

PREPARE ENGINE



SEPARATE THE IGNITERS

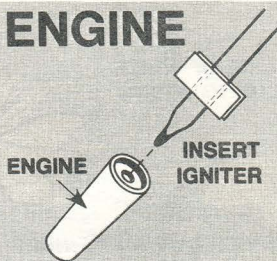

ENGINE

INSERT IGNITER

IGNITER TIP MUST TOUCH PROPELLANT DEEP INSIDE NOZZLE OPENING



FOLD OVER AND BEND TIPS

APPLY AND FIRMLY PRESS MASKING TAPE IN PLACE

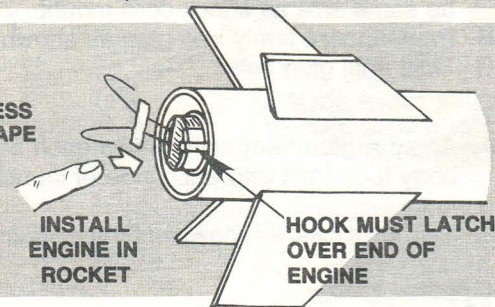
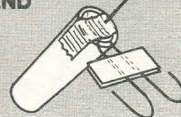

INSTALL ENGINE IN ROCKET

HOOK MUST LATCH OVER END OF ENGINE

LAUNCH SUPPLIES

To launch your rocket you will need the following items:

- An Estes model rocket launching system
 - Estes Recovery Wadding No. 2274
 - Recommended Estes Engines: A8-3, B4-4 (first flight), B6-4, B8-5, or C6-5.
- Use B4-4 engine for your first flight to become familiar with your rocket's flight pattern.

Use only Estes products with this set.

FLYING YOUR ROCKET

Choose a large field away from power lines, tall trees, and low flying aircraft. Try to find a field at least 250 feet square. The larger the launch area, the better your chance of recovering your rocket. Football fields and playgrounds are great.

Launch area must be free of dry weeds and brown grass.

Launch only during calm weather with little or no wind and good visibility.

Don't leave parachute packed more than a minute or so before launch during cold weather [Colder than 40° Fahrenheit (4° Celsius)].

Parachute may be dusted with talcum powder to avoid sticking.

MISFIRES

Failure of the model rocket engine to ignite is nearly always caused by incorrect igniter installation. An Estes igniter will function properly even if the coated tip is chipped. However, if the coated tip is not in direct contact with the engine propellant, it will only heat and not ignite the engine.

When an ignition failure occurs, remove the safety key from the launch control system and wait one minute before approaching the rocket. Remove the expended igniter from the engine and install a new one. Be certain the coated tip is in direct contact with the engine propellant, then tape the igniter leads firmly to base of engine as illustrated above. Repeat the countdown and launch procedure.

FOR YOUR SAFETY AND ENJOYMENT

Always follow the NAR-HIA* MODEL ROCKETRY SAFETY CODE while participating in any model rocketry activities.

*National Association of Rocketry-The Hobby Industry of America
page 4

COUNTDOWN AND LAUNCH

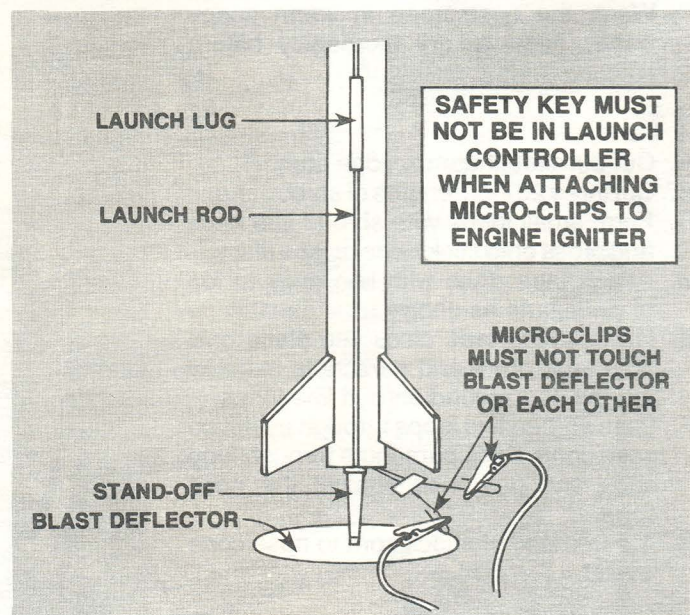

SAFETY KEY MUST NOT BE IN LAUNCH CONTROLLER WHEN ATTACHING MICRO-CLIPS TO ENGINE IGNITER

MICRO-CLIPS MUST NOT TOUCH BLAST DEFLECTOR OR EACH OTHER

- BE CERTAIN SAFETY KEY IS NOT IN LAUNCH CONTROLLER.
- Remove safety cap and slide launch lug over launch rod to place rocket on launch pad. Make sure the rocket slides freely on the launch rod.
- Attach micro-clips to the igniter wires. Arrange the clips so they do not touch each other or the metal blast deflector. Attach clips as close to protective tape on igniter as possible.
- Move back from your rocket as far as launch wire will permit (at least 15 feet).
- INSERT SAFETY KEY to arm the launch controller.
Give audible countdown 5...4...3...2...1

LAUNCH!!! PUSH AND HOLD LAUNCH BUTTON UNTIL ENGINE IGNITES
REMOVE SAFETY KEY FROM LAUNCH CONTROLLER.
REPLACE SAFETY KEY AND SAFETY CAP ON LAUNCH ROD.

3/32"

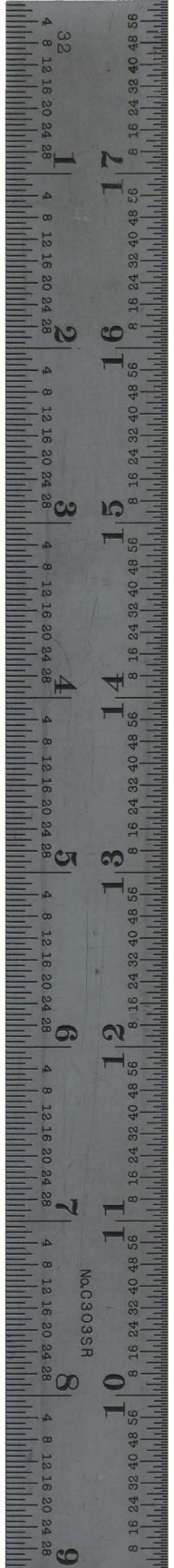
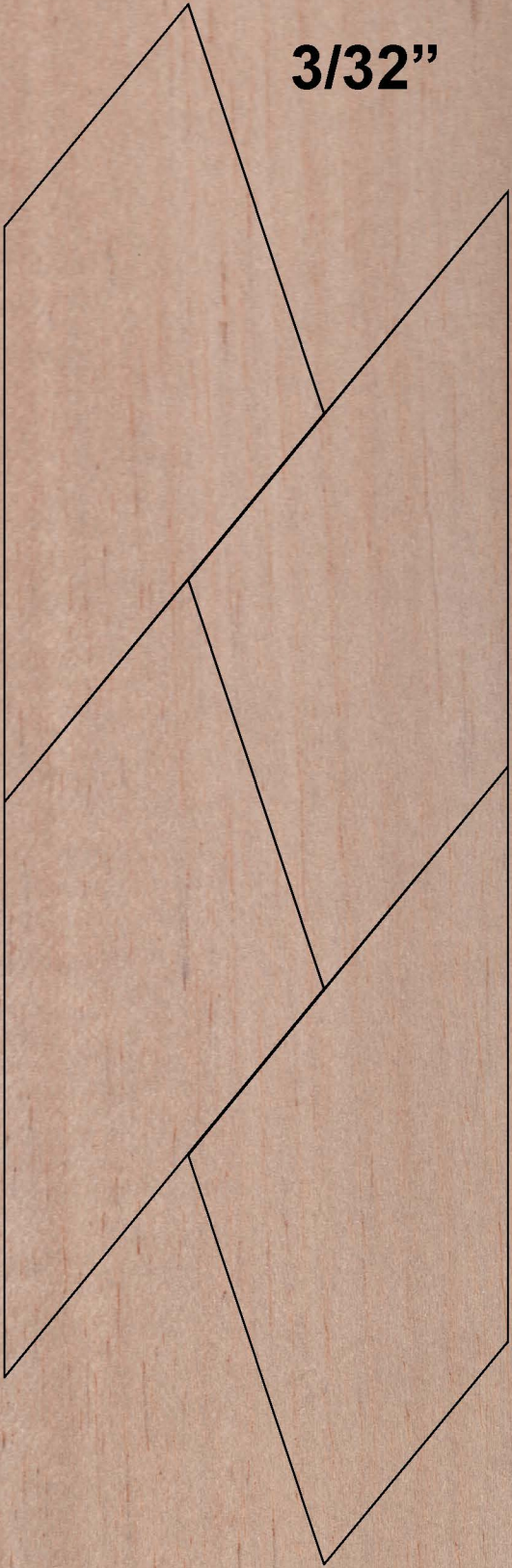

RAVEN RAVEN

TM

ESTES INDUSTRIES
PART NO. 37460

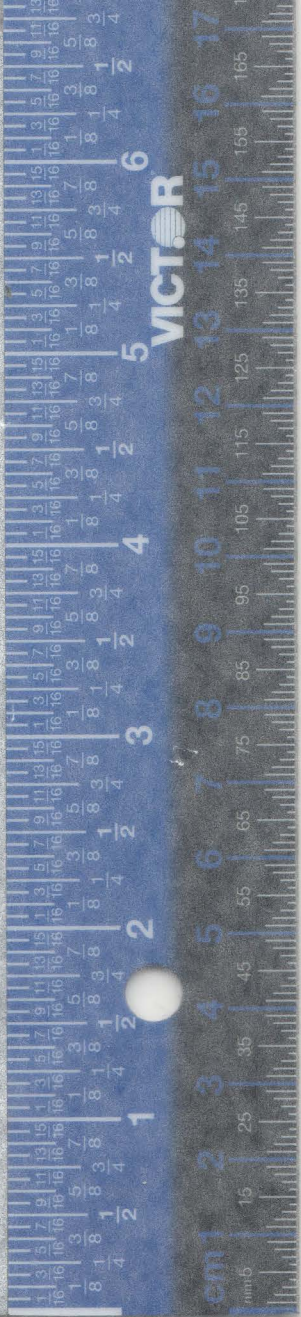
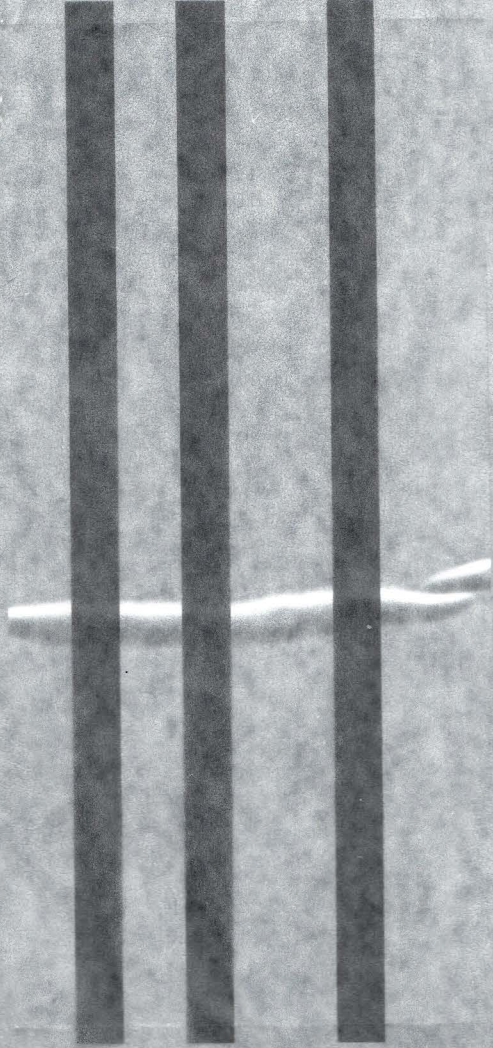

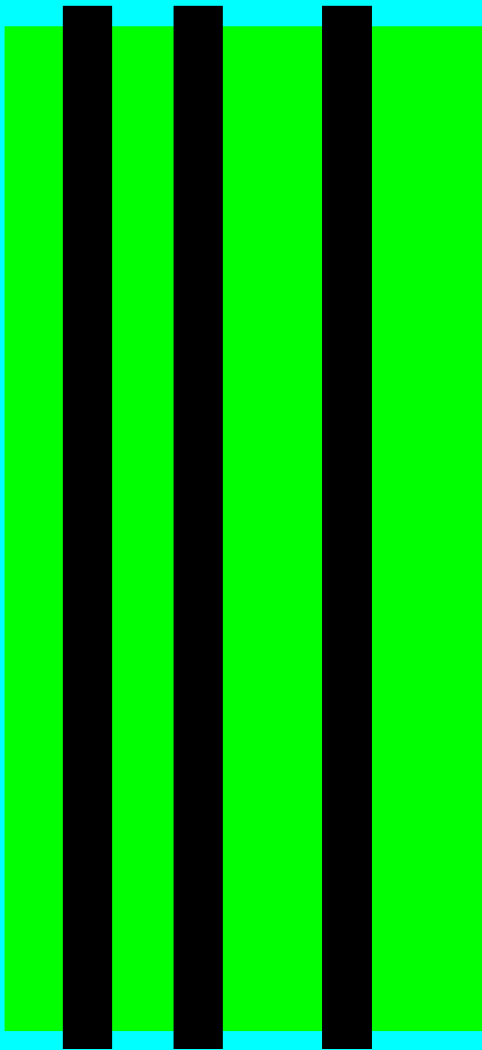
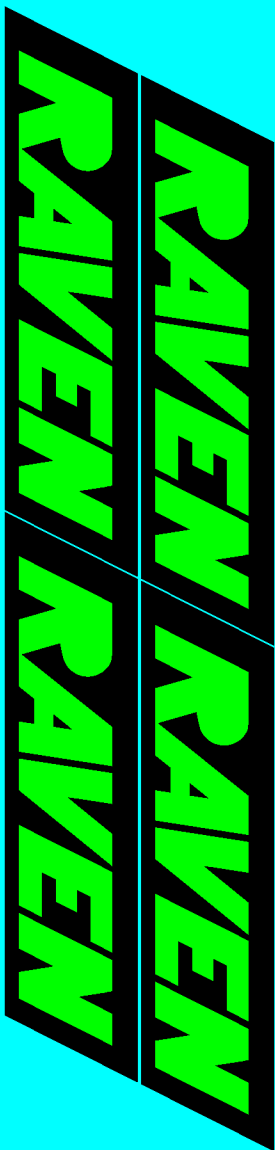

Re-drawn by: JimZ
Cyan=blank, Green=Chrome, Black=Black
Cut chrome tape to size and apply decal over tape.

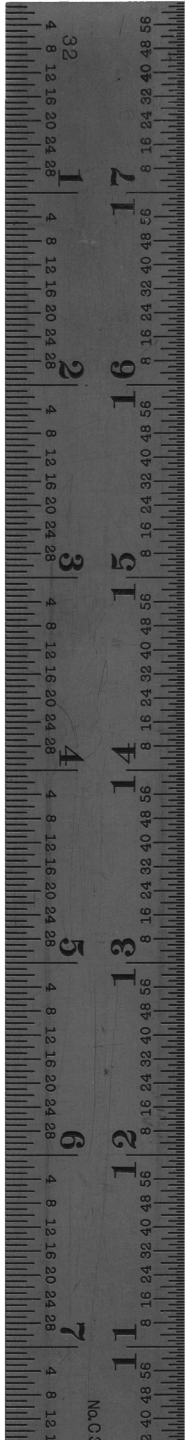

PARTS LIST KIT NO. 2029 - Raven								
Quantity	Description	Type	Number	Detail1	Detail2	Detail3	Detail4	Comment
1	PAPER BODY TUBE	BT-60	30396	18" long	1.595" ID	1.637" OD	0.021" wall	
1	PAPER BODY TUBE	BT-20J	30326	2.75" long	0.710" ID	0.736" OD	0.013" wall	Glassine
2	PAPER ADAPTER	RA-2060	3114	.737" ID	1.594" OD	.05" thick	BT-20 in BT-60	
1	ENGINE HOLDER	EH-2	3141/35025	2.8" long	.100" wide	.025" thick		Reg. & D
1	PLASTIC NOSE CONE	PNC-60RL	72305	9.25" long	1.627" dia.	.75" shoulder	BT-60 - Ogive	Blow molded
1	BALSA FIN STOCK	BFS-30	3168	3/32" thick	3" wide	9" long	0.09375	Scan
1	LAUNCH LUG	LL-2B	2323	5/32" ID	1/8" rod	2-3/8" long		
1	* Shock Cord	SC-1	85730/38367	18 " long	1/8" wide			Rubber
1	Shroud Line	SLT-72	38237	72"				
6	Tape Disc	TD-3F	38406	1/2" dia.				6x
1	Parachute	PK-12	2263/85564	12" dia.				
1	Decal	D-2029	37460	7" long	5" wide	Chrome/Black	Selfstick	Scan

* Shock Cord only 11" long in sample kit.

Flying Model Rocket

RAVEN

FLYING
MODEL
ROCKET

Easy to Fly!

It's the most exciting place to go for model rockets. You can launch your rocket from the ground or from a launch pad. You can launch your rocket from a launch pad or from a launch pad. You can launch your rocket from a launch pad or from a launch pad.



Estes is a leader in rocket technology. Our rockets are designed for safety and fun. Our rockets are designed for safety and fun. Our rockets are designed for safety and fun.

Light Force

1 Insert the nose cone into the body tube. Push the nose cone into the body tube until it is seated. The nose cone is the front part of the rocket. It is the part that will be at the front of the rocket when it is launched.

2 Insert the fins into the body tube. Push the fins into the body tube until they are seated. The fins are the part that will be at the back of the rocket. They are the part that will keep the rocket from tumbling.

3 Insert the body tube into the launch pad. Push the body tube into the launch pad until it is seated. The launch pad is the part that will hold the rocket while it is being launched.

4 Attach the launch pad to the launch rail. Push the launch pad into the launch rail until it is seated. The launch rail is the part that will hold the launch pad while it is being launched.

5 Attach the launch rail to the launch pad. Push the launch rail into the launch pad until it is seated. The launch pad is the part that will hold the launch rail while it is being launched.

6 Attach the launch pad to the launch rail. Push the launch pad into the launch rail until it is seated. The launch rail is the part that will hold the launch pad while it is being launched.

7 Attach the launch rail to the launch pad. Push the launch rail into the launch pad until it is seated. The launch pad is the part that will hold the launch rail while it is being launched.

8 Attach the launch pad to the launch rail. Push the launch pad into the launch rail until it is seated. The launch rail is the part that will hold the launch pad while it is being launched.

LAUNCHING THE ROCKET: ...

PARACHUTE: ...

SAFETY: ...

WARRANTY: ...

THE YEAR WARRANTY AND SAFETY CODE ENCLOSED

USE ONLY ESTES PRODUCTS TO LAUNCH THIS MODEL ROCKET

RAVEN

FLYING MODEL ROCKET

SKILL LEVEL 1

- SLICK SPORT FLIER
- Die-Cut Paper Fins
- Plastic Nose Cone
- 1/2 Inch Parachute
- Silver Felt Decal
- Quick-Release
- Engine Mount

Length: 24.5 in. (62.2 cm)
Wing Span: 10.5 in. (26.7 cm)
Weight: 3.31 oz. (93 g)

Recommended Engines:
Aerotech® A6-3, A6-4, A6-5, A6-6,
A6-7, A6-8, A6-9

FLYING
MODEL
ROCKET
KIT



This is a model kit requiring assembly. This kit includes a motor, motor mount, and engine. For more information, visit www.aerotech.com.



0000

