

SEA "D" STRIKE FLYING MODEL ROCKET

SKILL LEVEL 3

1-Beginner 2-Intermediate 3-Craftsman
4-Advanced 5-Expert

Scale-like ship-to-air missile with two-stage super "D" engine power. High performance design for incredible 1,800 foot flights. Huge, four-color decal sheet for realistic military appearance. Features include die-cut balsa fins, plastic nose cone, tumble recovery booster, and 12" parachute recovery for upper stage.



Specifications

Length 31" (78.75 cm)
Diameter 1.34" (34 mm)
Weight 3.35 oz. (95 g)
12" Parachute Recovery

Recommended Engines

SINGLE STAGE
D12-5 (First Flight)
D12-7 D11-9

TWO STAGE

D12-0 D12-7
D11-9

This is a hobby kit requiring assembly. Recommended for ages 10 to adult. Engines, launch system, glue and finishing supplies are not included. Adult supervision is suggested for those under 12 years of age when flying model rockets.



ESTES INDUSTRIES
RENNESSE, CO. 81640 USA



1332

SEA "D" STRIKE

BEFORE YOU START

Read all instructions before beginning work on your model. Make sure you have all parts and materials. When you are thoroughly familiar with the assembly procedure, begin construction. Check off each step as you complete it. In each step, test-fit the parts together before applying any glue. If some part doesn't fit properly, sand lightly or build up as required for precision assembly.

SKILL LEVEL 3 – Recommended for Craftsman Rocketeers.



A DAMON COMPANY

ESTES INDUSTRIES
PENROSE, CO 81240 USA

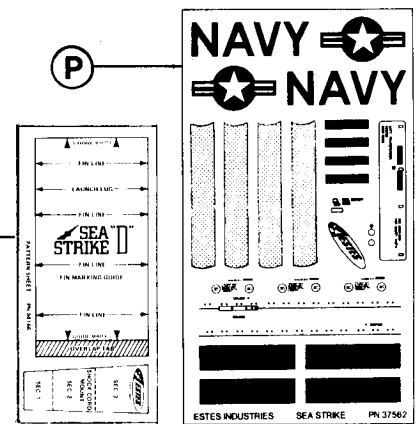
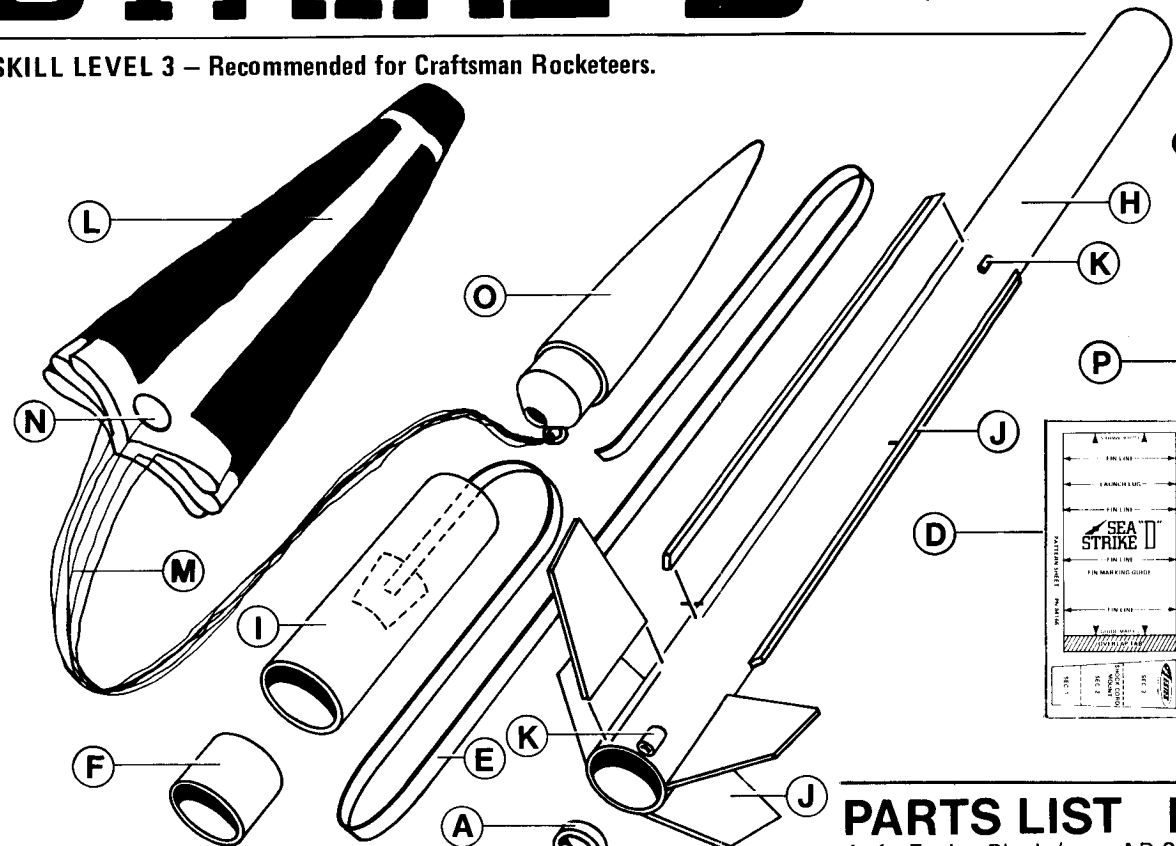

RECOMMENDED ENGINES:
BOOSTER D12-0 UPPER STAGE D11-9
SINGLE STAGE LAUNCHES:
D12-5

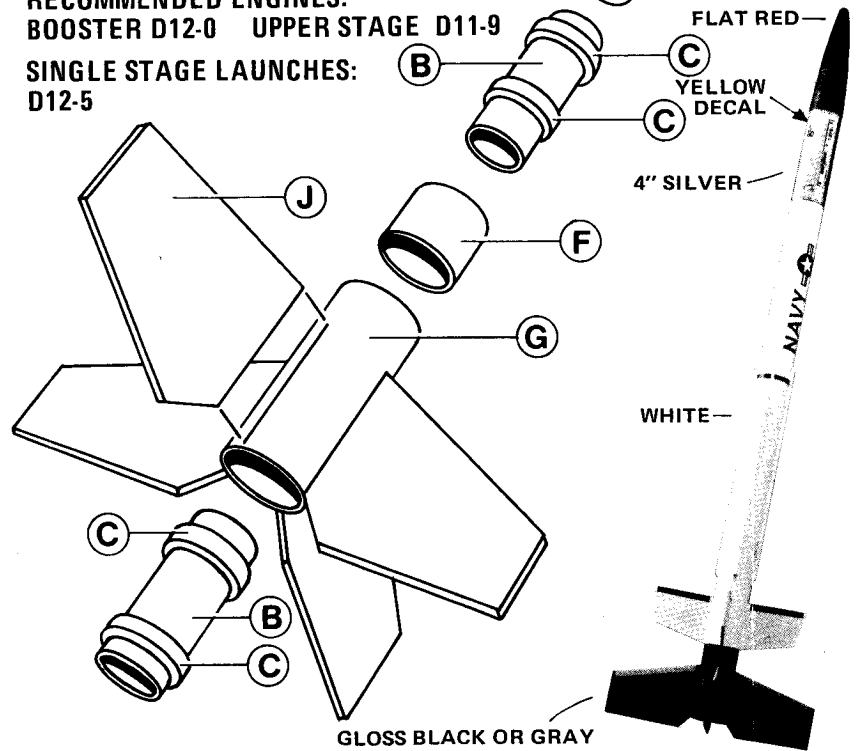

PARTS LIST KIT NO.1332

A	1	Engine Block (type AR-2050)	30164
B	2	Engine Mount Tube (type BT-50J)	30362
C	4	Adapter Ring (type AR-5055)	30166
D	1	Pattern Sheet (type SP-1332)	84166
E	1	Shock Cord (type SC-1)	85730
F	2	Stage Coupler (type JT-55C)	30262
G	1	Body Tube (type BT-55J) 2-3/4"	30386
H	1	Body Tube (type BT-55) 18"	30382
I	1	Body Tube (type BT-55S) 4"	30390
J	2	Balsa Die-Cut Fin Sheet (type BF-1332)	32334
K	2	Launch Lug (type LL-2AM)	38176
L	1	Parachute (type PK-12A)	85564
M	1	Shroud Line (type SLT-72)	38237
N	1	Tape Discs (type TD-3F)	38406
O	1	Nose Cone (type PNC-55AO)	71075
P	1	Decal (type KD-1332)	37562

TOOLS AND MATERIALS

Identify all parts as shown in the Parts View. Lay the parts out on the table in front of you. In addition to the parts included in the kit you will need:

- White glue (Titebond, Elmer's, or similar).
- Sandpaper.
- Scissors.
- A sharp model knife, or a single-edge razor blade
- A ruler and pencil.
- Sanding sealer and small paint brush.
- Gloss white, silver, black or gray, and flat red paint. (Spray paint is recommended.)

ASSEMBLY INSTRUCTIONS

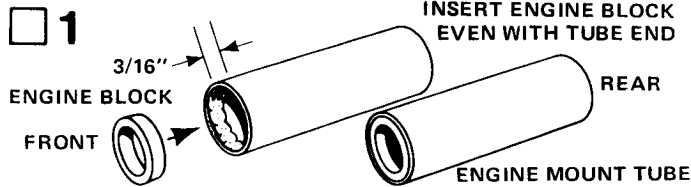

Glue the engine block (part A) in one end of one of the engine mount tubes (part B). To do this, apply glue around the last 3/16" on the inside of the tube. Immediately slide the engine block into the same end of the tube so the end of the block is even with the end of the tube. Let the unit sit a minute, then wipe off any excess glue.

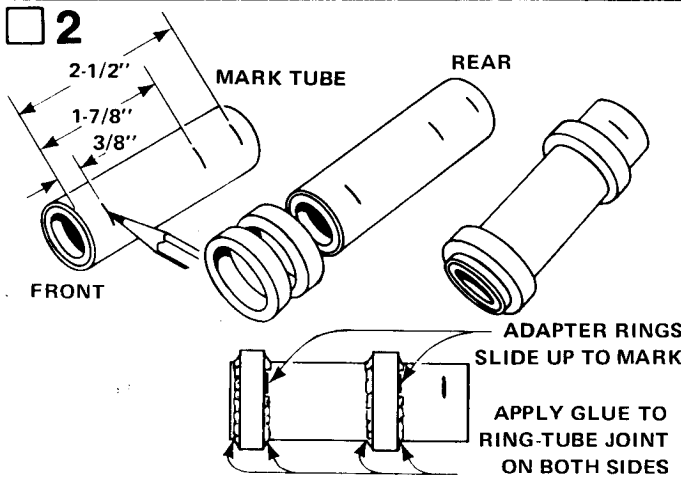

Mark the engine mount tube 3/8", 1-7/8", and 2-1/2" from the front (the end with the engine block). Slide two of the adapter rings (part C) onto the tube. Position one ring in front of the 3/8" mark and the other in front of the 1-7/8" mark as shown. Glue the rings in place by applying a line of glue where the rings meet the tube -- all around both sides. Set the assembly on end while the glue dries.

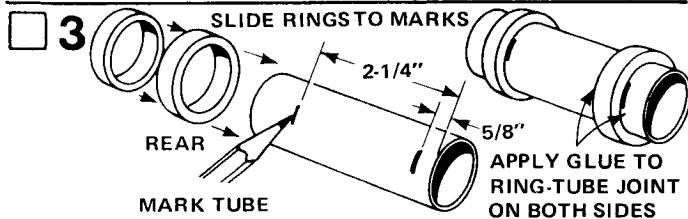

Mark the remaining engine mount tube 5/8" and 2-1/4" from one end. Glue an adapter ring to the tube at each mark. (Use the same gluing technique as in step 2.) Set the assembly on end while the glue dries.

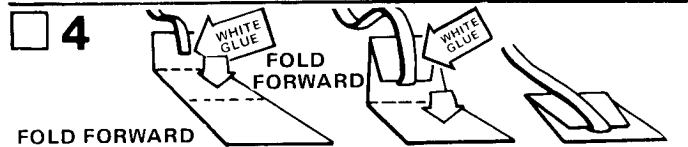

Cut out the shock cord mount from the pattern sheet (part D). Crease it on the dotted lines by folding. Spread glue on the first section (1) and lay the end of the shock cord (part E) into the glue. Fold over and apply glue to the back of the first section and the exposed part of section 2. Clamp the unit together with your fingers until the glue sets.

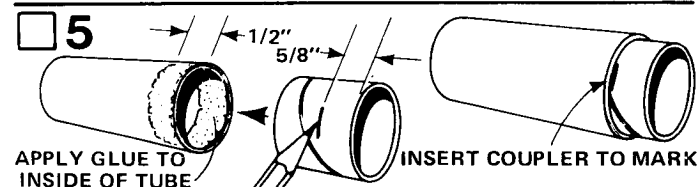

Mark one stage coupler (part F) 5/8" from one end. Apply glue around the last 1/2" inside one end of the booster body tube (part G - 2-3/4" long). Slide the coupler in until the mark is even with the end of the tube. Let the unit sit a minute, then wipe off any excess glue.

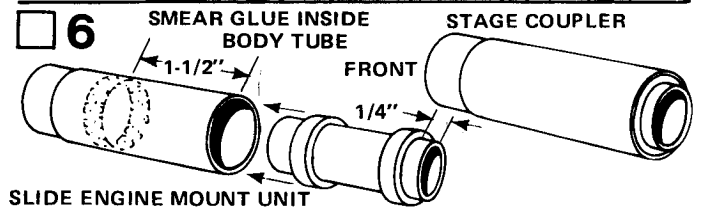

Smear a line of glue approximately 1/2" wide around the inside of the booster body tube 1-1/2" from the rear (the end opposite the stage coupler). Slide the engine mount unit (without the engine block) into the body until the rear ring is even with the tube end as shown.

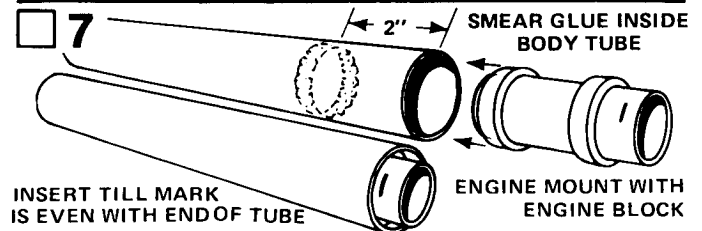

Smear a line of glue approximately 1/2" wide around the inside of the main body tube (part H) 2" from one end of the tube. Slide the engine mount unit, engine block end first, into the body until the mark on the engine mount tube is even with the end of the tube. Do not pause while inserting the engine mount or the glue may "grab" with it in the wrong position.

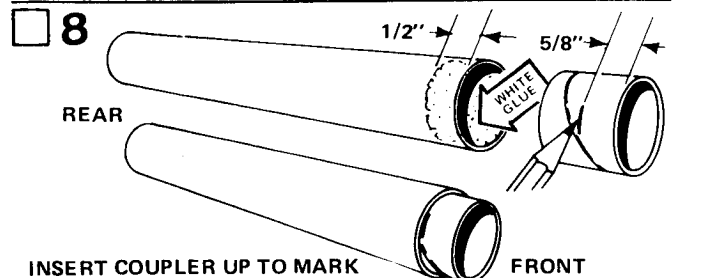

Mark the remaining stage coupler 5/8" from one end. Apply glue around the last 1/2" inside the main body tube end opposite the engine mount. Slide the coupler in until the mark is even with the end of the tube. Let the unit sit a minute, then wipe off any excess glue.

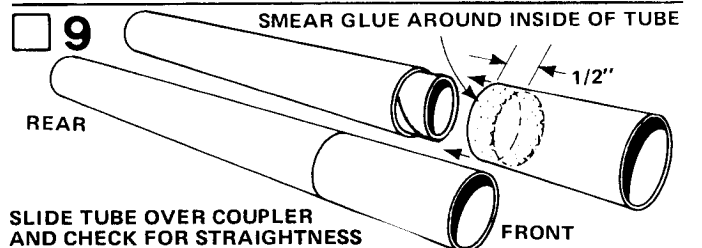

Apply glue around the last 1/2" inside one end of the 4" body tube (part I). Slide this end onto the protruding coupler on the main body tube until the two tubes touch. Sight along the unit to be sure the tubes are straight.

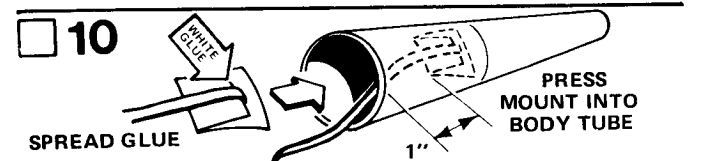

Apply glue liberally to the back side of the shock cord mount and press the mount firmly into the front end of the upper stage body tube at least 1" from the end. Hold the shock cord mount firmly until the glue sets.

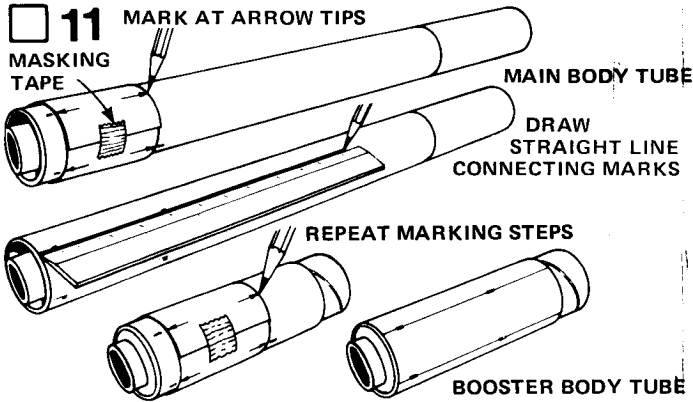

Cut out the body tube marking guide from the pattern sheet. Wrap it around the rear of the main body. Mark the tube at each arrow point, front and rear. Draw a straight line connecting each matching front and rear mark. (Use a ruler when drawing lines.) Extend all lines forward 12". Mark the booster tube for four fins in the same way.

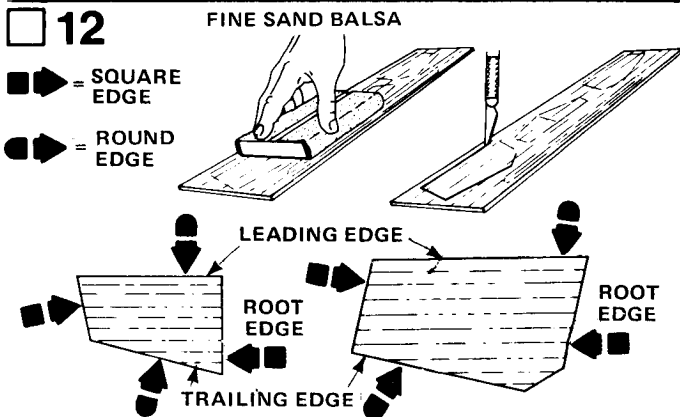

Fine-sand the balsa fin sheets (part J), then carefully remove the die-cut parts from the sheet. Free the edges with a sharp knife. Sand the leading and trailing edges of the fins round. Leave the other edges square.

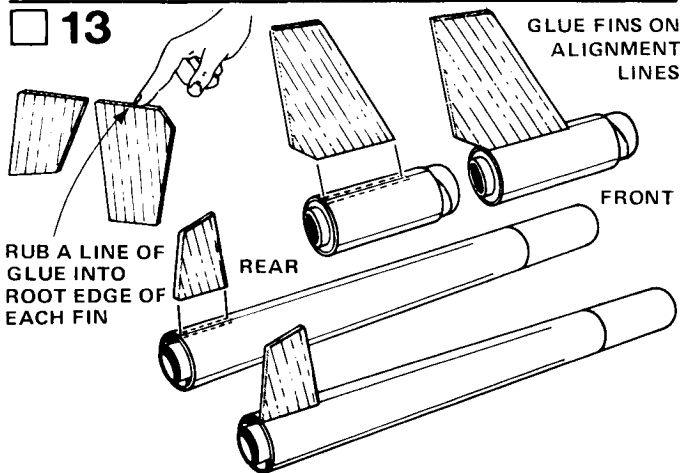

Rub a line of glue into the root edge of each fin and allow to dry. Glue the fins to the main body and the booster body on the fin alignment lines drawn in step 11. Refer to the illustration to be sure you position the fins correctly. The rear edge of each fin should be even with the rear edge of the body tube. Adjust the fins so they project straight away from the body tube. Do not set the rocket on its fins while the glue is wet.

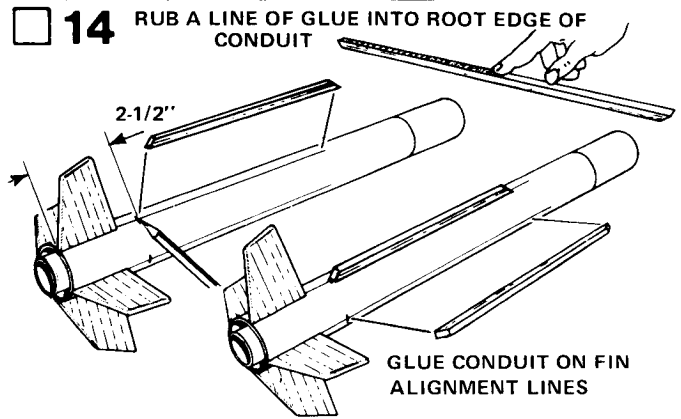

Mark the fin alignment lines on the upper stage body tube 2-1/2" from the rear. Rub a line of glue into the root edge of each conduit cover and allow to dry. Glue the conduit covers on the fin alignment lines with the rear ends on the 2-1/2" mark. Sight along the tube to be sure they are straight and are in line with the fins.

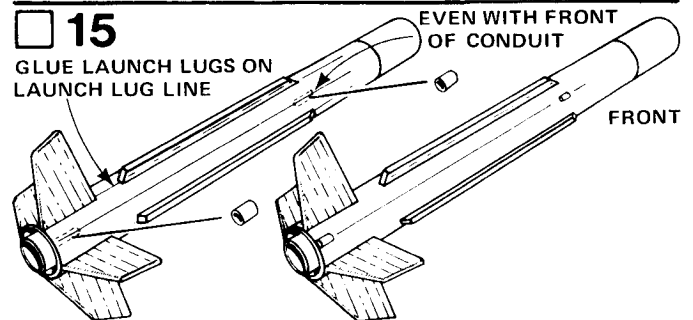

Glue the two launch lugs (part K) on the launch lug line of the upper stage body tube. Glue one lug even with the rear of the tube. Glue the remaining lug with its front even with the front of the adjacent conduit covers.

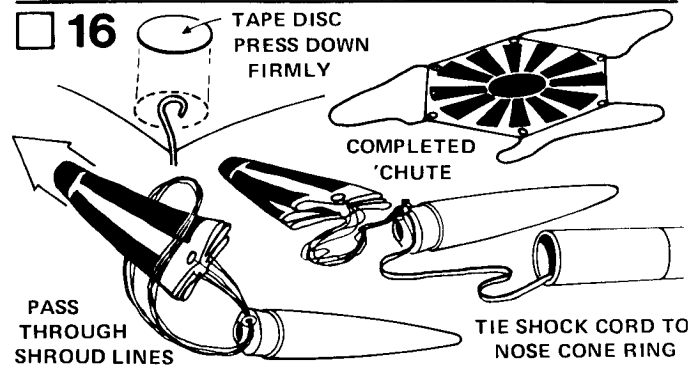

Cut out the parachute (part L) on its edge lines. Cut three 24" lengths of shroud line (part M). Attach line ends to the top of the parachute with tape discs (part N) as shown. Pass the shroud line loops through the ring on the nose cone (part O). Pass the parachute through the loop ends and draw the lines tight against the ring. Set knot with a drop of glue. Tie the free end of the shock cord to the nose cone ring.

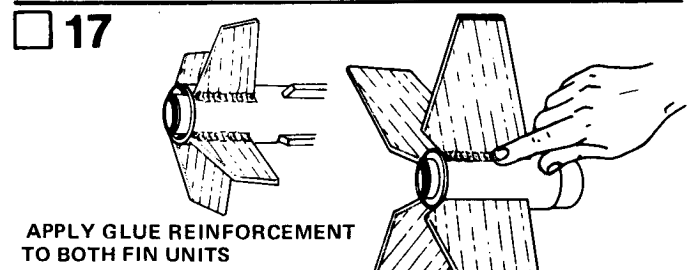

Apply a glue reinforcement to each fin joint. Holding the rocket horizontally (level), apply a line of glue to both sides of each joint. Smooth out the glue with your finger. Keep the rocket level until the glue dries.

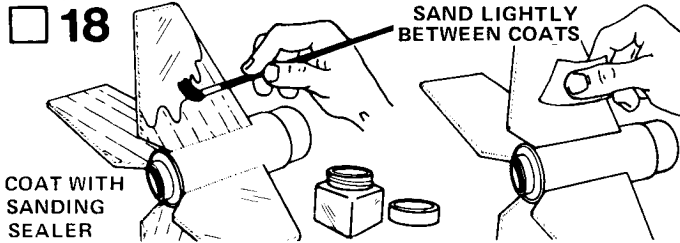

When all glue on the outside of the body is dry, prepare the model for painting. Apply at least two coats of sanding sealer to all wood parts. Let dry and sand lightly between coats. Do this until the tiny holes in the wood are filled and everything looks and feels smooth. Paint the entire rocket white. When the white is completely dry, paint the nose cone flat red and front 4" of the main body silver. Paint the entire booster gloss black or gray. Use masking tape and paper to mask areas to be protected while painting small sections of the rocket.

19 When all paint is dry (allow at least overnight for drying), apply decals (part P). Cut out a decal section, dip it in lukewarm water for 10-20 seconds, and hold it until it starts to uncurl. Slip the decal off the backing sheet and onto your model. Blot away excess water. For best results, let the model dry overnight and apply a coat of clear spray to protect the decals.

FLYING YOUR SEA STRIKE "D"

Your Sea Strike "D" model has been designed as a high performance two-stage sport model. The upper stage may also be flown by itself as a single stage sport or demonstration model. Here are some suggestions for getting the best results from your model:

- Obtain a copy of Estes Industries Technical Report TR-2 and study it before flying two-stage models.
- Always be extra careful when installing engines. Make sure they face the correct direction for proper staging. Make sure they are held tightly in place to insure proper recovery operation.
- Have an extra person with you when launching to watch the booster stage and retrieve it after flight.
- Launch in calm weather. The upper stage will drift a long way in a wind.
- When flying as a single stage model, make sure the engine is securely held in place.
- Always follow the Countdown Checklist when launching your model.
- To launch your rocket, you will need the following launch components: an Estes model rocket launch system, parachute recovery wadding (Estes Cat. No. 2274), Estes booster D12-0 and upper stage D11-9 model rocket engines, or D12-5 engine for single stage launches.

Be sure to follow the HIAA-NAR* Model Rocketry Safety Code when carrying out all your model rocketry activities.
 *HIAA -- Hobby Industry Association of America
 NAR -- National Association of Rocketry

COUNTDOWN CHECKLIST

T-17 Pack 8 to 10 squares of loosely crumpled recovery wadding into the body tube from the front.

NOTE: DO NOT pack parachute until you are actually ready to launch. For maximum parachute reliability, lightly dust the chute with ordinary talcum powder before each flight, especially in cold weather.

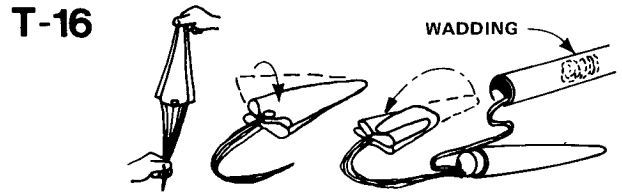

Gather the parachute as shown, then fold into a triangular shape. Fold again and insert into rocket body.

T-15 Pack the shock cord neatly into rocket, then slide nose cone in place. Nose cone should separate easily from rocket body tube, but should not be extremely loose. If it is too tight, sand inside of body tube end and shoulder of nose cone with extra fine sandpaper. If nose cone is too loose, add a wrapping of transparent tape or masking tape to the shoulder of the nose cone.

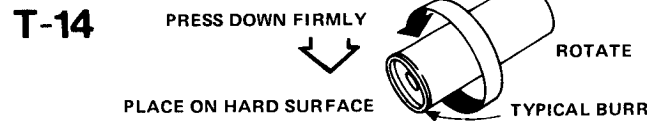

Select an upper stage engine and a booster engine. Remove any burrs from the ends of the engines by holding them against a smooth surface and turning.

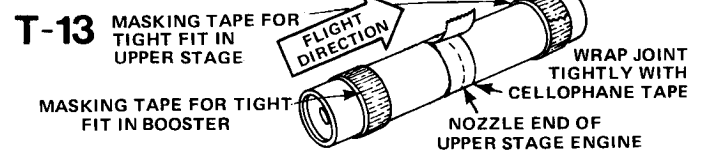

Position the engines with the nozzle of the upper stage engine against the top end of the booster engine. Wrap a layer of cellophane tape tightly around the joint as shown. Check to be sure the engines are in their proper relative positions.

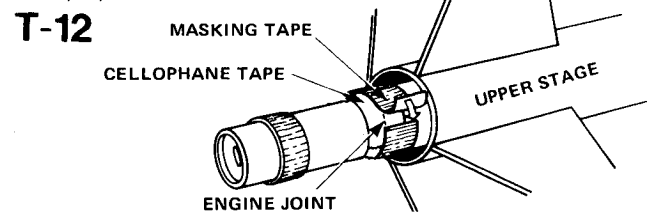

Wrap masking tape around the top of the upper stage engine so it makes a tight friction fit in the engine mount tube. Insert the upper stage end of the engine unit into the upper stage engine mount. Finish securing it by wrapping a layer of masking tape around the end of the engine mount tube and the end of the engine as shown. Press the tape tightly against the engine.

T-11 Slide the booster into place on the engine unit from the bottom. Position it so the stage coupler fits all the way into the upper stage and the fins are in line. Secure the booster in place by wrapping a layer of masking tape around the end of the engine mount tube and the engines. Press the tape down tightly.

T-10 Install an igniter in the booster engine as directed in the engine instructions.

T-9 Disarm the launch panel -- REMOVE SAFETY KEY.

T-8 Place the rocket on launch pad, making sure rocket slides freely on the launch rod. Clean the micro-clips and attach them to the igniter.

T-7 Clear the launch area, alert recovery crew and trackers. Check for low flying aircraft and unauthorized persons in the recovery area.

T-6 Arm the launch panel -- INSERT SAFETY KEY.

-5-4-3-2-1-LAUNCH!!

MISFIRE PROCEDURE

Occasionally the igniter will heat and burn into two pieces without igniting the engine. This is almost always caused by a failure to install it correctly. Disarm the launch panel, remove the model, clean the igniter residue from the nozzle, and install a new igniter. Follow the launching procedure again.

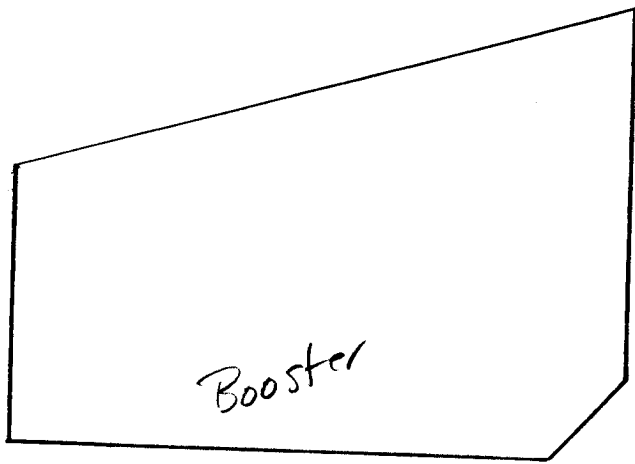

Sea Strike "D"

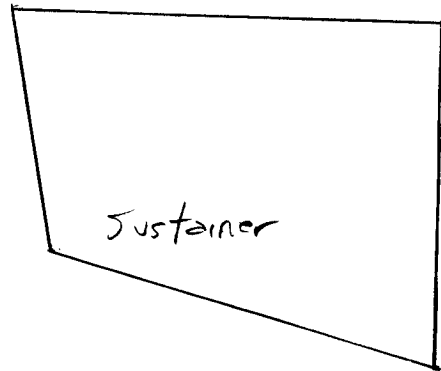

Strokes

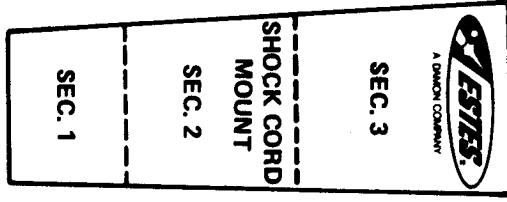
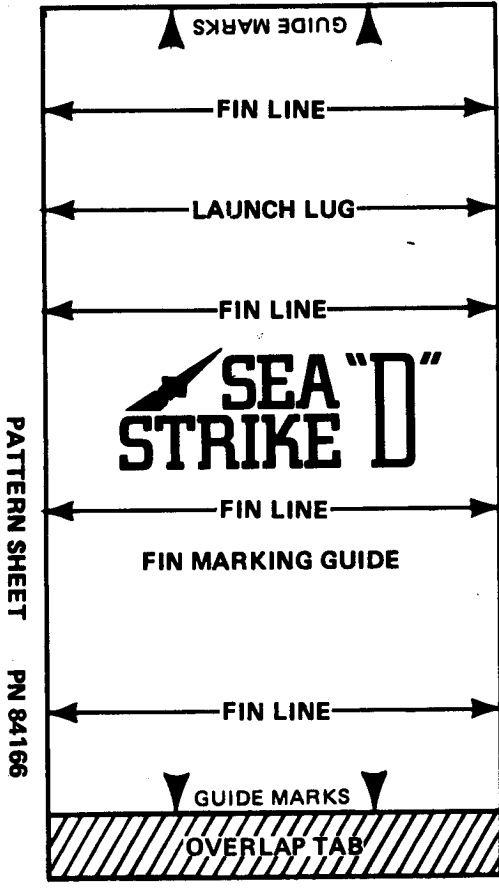

NAVY



NAVY



ESTES INDUSTRIES

SEA STRIKE

PN 37562