



# Scorpius

**SKILL LEVEL 3 –**  
Recommended for Craftsman Rocketeers.

## BEFORE YOU START

Read each step and study the accompanying drawings before doing any of the work called for in that step. Make sure you have all parts and materials. Check off each step as you complete it. Always test-fit parts together before applying glue. It will sometimes be necessary to sand edges of rings, tubes, etc. to obtain a proper fit. If you are in doubt about the relative size or location of some parts, refer back to this exploded view drawing for clarification. Adequate glue joints are very important for a flying model rocket. Follow the instructions carefully in this regard.

**RECOMMENDED ENGINES:**  
A8-3, B4-4, B6-4, B8-5, C6-5  
First Flight A8-3



A DAMON COMPANY

**ESTES INDUSTRIES**  
PENROSE, CO 81240 USA

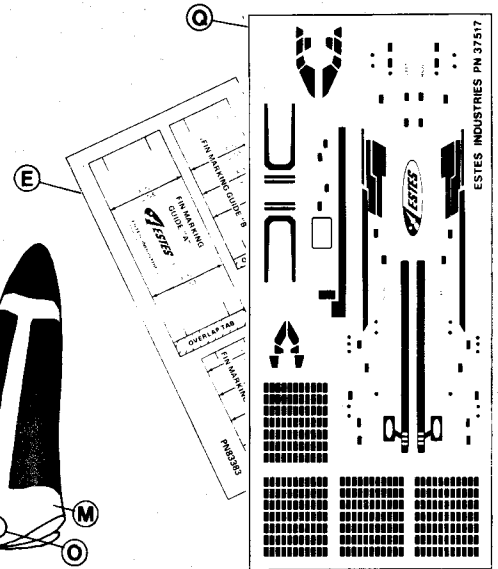

## TOOLS AND MATERIALS

In addition to the parts included in this kit you will need: Scissors, pencil, ruler, fine or extra-fine grit sandpaper, sanding sealer, a medium-size modeling paint brush, modeling knife with sharp blade, aircraft grey enamel spray paint, and household white glue or resin glue (Elmer's, Titebond, or similar). Other types of glue are not recommended.

## PARTS LIST KIT NO. 1375

A	1	Engine Mount Tube (type BT-20J) . . . . .	30326
B	1	Engine Hook (type EH-2) . . . . .	35025
C	2	Adapter Rings (type AR-2050) . . . . .	30164
D	1	Die-Cut Balsa Fin Sheet (type BF-1375) . . . . .	32384
E	1	Pattern Sheet (type SP 1375) . . . . .	83383
F	1	Body Tube (type BT-50L) 12.7" long . . . . .	30366
G	4	Body Tube (type BT-20AE) 1-1/2" . . . . .	30318
H	4	Body Tube (type BT-5T) 1-1/2" long . . . . .	30308
I	4	Adapter Rings (type AR-520) . . . . .	30162
J	8	Wooden Dowels (type WD-2C) . . . . .	85912
K	1	Plastic Nose Cone (type PNC-50X) . . . . .	71010
L	1	Shock Cord (type SC-1) . . . . .	85730
M	1	Parachute (type PK-12) . . . . .	85564
N	1	Shroud Line (type SL-72) . . . . .	38237
O	1	Tape Disc Set (type TD-3F) . . . . .	38406
P	2	Launch Lug (type LL-2AM) . . . . .	38176
Q	1	Decals (type KD-1375) . . . . .	37517

# ASSEMBLY INSTRUCTIONS

1

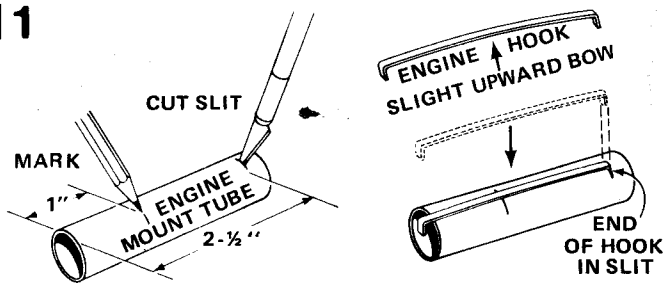

Mark the engine mount tube (part A) at 1" and 2-1/2" from one end. Cut a 1/8" long slit at the 2-1/2" mark. Gently bend the engine hook (part B) so that it bows upward very slightly in the middle. (Study the drawing - Don't bend the wrong way.) Insert one end of the engine hook into the slit in the tube.

2

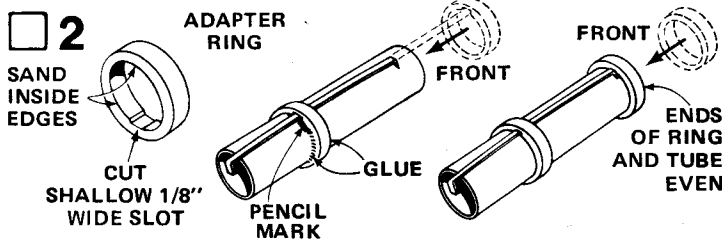

Sand the inside edges of the two adapter rings (part C) to remove burrs. The rings should slide easily onto the engine mount tube. Cut a very shallow 1/8" wide slot inside one adapter ring so it will fit over the engine hook. Slip the ring onto the front end of the engine mount tube and slide it down to the 1" mark. Make sure the engine hook runs straight down the tube, then apply glue to both sides of this adapter ring. Apply glue around the front end of the engine mount tube and slide the remaining adapter ring into place (front of ring even with the end of the tube).

3

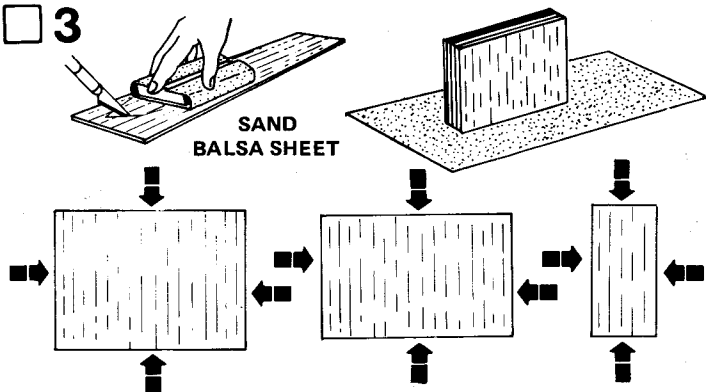

Fine-sand the balsa die-cut sheet (part D). Free the fin edges with a sharp knife, then carefully remove the fin die-cuts from the sheet. Stack the fins into three sets as shown. Sand all of the fin edges square as shown. Lightly sand both sides of each fin. Leave all of the fin edges square.

4

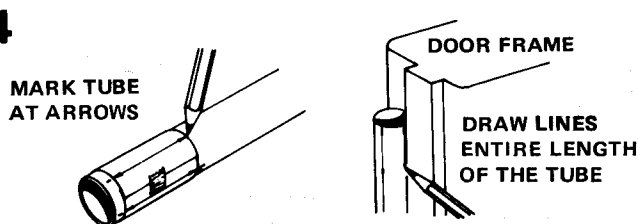

Cut out the "A" fin marking guide from the pattern sheet (part E). Wrap the guide around the main body tube (part F). Match up the alignment marks and tape the guide together. Mark the body tube at each of the four arrow points. Remove the guide. Draw straight lines connecting each pair of marks. A door frame inside edge can be used as a guide as shown. Extend the lines the entire length of the body tube.

5

MARK TUBE AT ARROWS

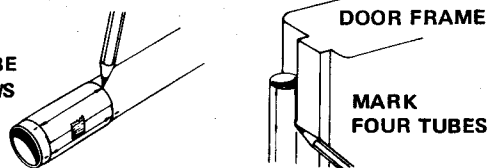

Cut out the "B" fin marking guide from the pattern sheet. Locate the four larger 1-1/2" long body tubes (part G). Wrap the guide around one of the body tubes. Matching up the alignment marks, tape the guide together. Mark the body tube at each of the six arrow points. Remove the guide. Draw straight lines connecting each pair of marks. A door frame inside edge can be used as a guide as shown. Extend the lines the entire length of the body tube. Slip the guide onto the remaining larger body tubes repeating the process for each.

6

MARK TUBE AT ARROWS

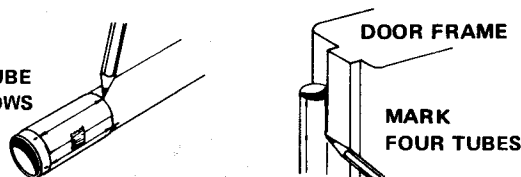

Cut out the "C" fin marking guide from the pattern sheet. Locate the four smaller 1-1/2" long body tubes (part H). Wrap the fin marking guide around one of the body tubes. Matching up the alignment marks, tape the guide together. Mark the body tube at each of the eight arrow points. Remove the guide. Draw straight lines connecting each pair of marks. A door frame inside edge can be used as a guide as shown. Extend the lines the entire length of the body tube. Slip the fin marking guide onto the remaining smaller body tubes repeating the process for each.

7

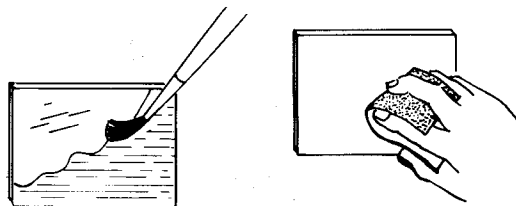

Proper application of sanding sealer makes the rocket look better and reduces drag so that the rocket will fly higher. However, this step is not essential to make a safe, attractive rocket. Apply a coat of sanding sealer to each fin. When sealer is dry, lightly sand all the sealed surfaces. Repeat sealing and sanding process until balsa grain is filled and smooth.

8

MAKE TWO

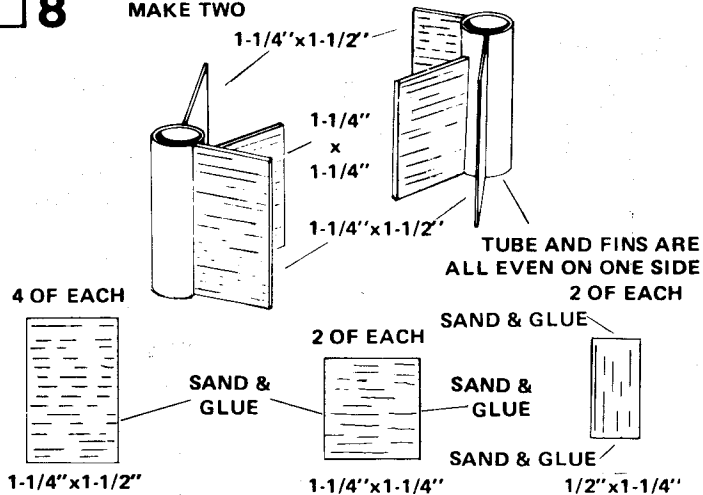

Separate the fins into the three sizes. Sand the edges of each which will be glued, to remove the sanding sealer on those edges. Rub a line of glue into the edges of each fin as illustrated. NOTE: Pay close attention to the direction of the grain on each of the fins. Allow the glue to dry. Glue one of the 1-1/4" x 1-1/4" fins to the middle line of the larger 1-1/2" long body tubes so that the rear of

the fin is even with the rear of the body tube. Adjust the fin so that it projects straight away from the body tube. Glue two of the 1-1/4" x 1-1/2" fins to the outside lines of the body tube as shown. Adjust the fins so that they project straight away from the body tube. Stand the unit up on end for the glue to dry. Repeat this for one of the other large body tubes.

□ 9

MAKE TWO

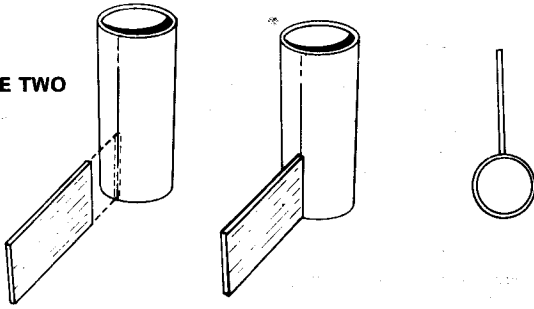

Glue one of the 1-1/4" x 1/2" fins to one of the large 1-1/2" long body tubes, on one of the alignment lines, so that the rear of the fin and the rear of the body tube are even as shown. Adjust the fin so that it projects straight away from the tube. Stand the tube on end to dry. Repeat this process for the remaining large body tube and small fin.

□ 10

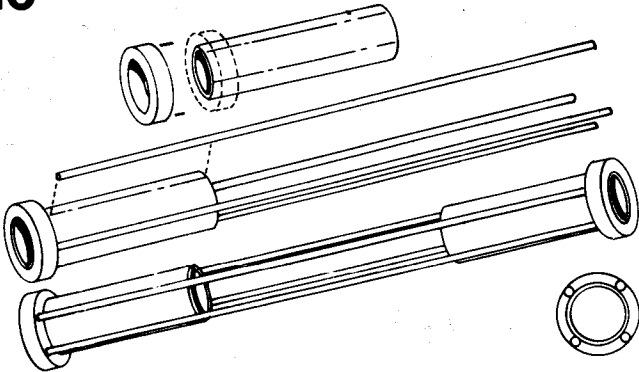

Locate the four small 1-1/2" long body tubes, the four adapter rings (part I), and the eight wooden dowels (part J). Glue one adapter ring onto the end of each of the smaller body tubes so that the end of the adapter ring and body tube are even. Glue one of the dowels to each of the guide lines drawn in Step 6 on two of the body tubes so that the end of the dowel is against the adapter ring. NOTE: Since the dowels may be slightly warped, adjust the dowels so that they point inwards. Wrap rubber bands around the two units to hold the dowels in place. Readjust the dowels if necessary. Glue the other end of the dowels onto the other two body tubes in the same manner. Wrap rubber bands around these ends and set the assemblies aside to dry.

□ 11

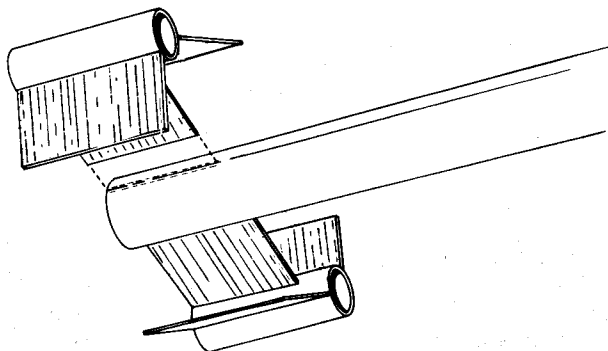

Glue the rear fin assemblies to the main body tube as shown. Make sure the fins are properly positioned on the alignment lines and the rear of the fins are even with the rear of the body tube. Stand the rocket up on a flat surface and adjust the fins so that they project straight away from the body tube. A piece of wax paper may be used under the rocket to prevent gluing it to the surface. Allow the unit to dry completely.

□ 12

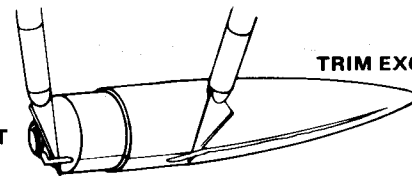

TRIM EXCESS PLASTIC

CLEAR EYELET

Trim or sand any excess plastic from around the sides of the nose cone (part K). Use a sharp knife to remove any excess plastic from the inside of the molded eyelet at the rear of the nose cone. Wash the nose cone with lukewarm soapy water, rinse well, and dry.

□ 13

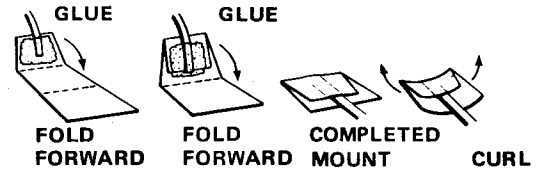

FOLD FORWARD

FOLD FORWARD

COMPLETED MOUNT

CURL

Cut out the shock cord mount from the pattern sheet. Fold on dotted lines, then unfold and apply glue to Section 1. Lay the end of the shock cord (part L) into the glue. Fold over and apply glue to the back of Section 1 and the exposed portion of Section 2. Fold again to complete mount. Curl the edges of the mount up so it will match the contour of the body tube and hold with your fingers until the glue sets.

□ 14

SET BACK TO ALLOW FOR NOSE CONE

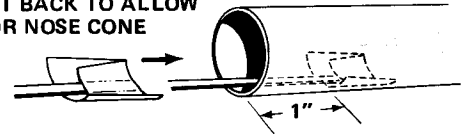

Use a finger or stick to apply glue to the inside of the front of the body tube, 1" to 2" from the front of the tube. Press the shock cord mount firmly into position in glue far enough from the front edge of the tube to allow clearance for the nose cone to fit into place. To insure a good bond use a stick or your finger to smear a film of glue over the mount and surrounding area in the body tube.

□ 15

TAPE DISC

PRESS DOWN FIRMLY

COMPLETED 'CHUTE

SHROUD LINE

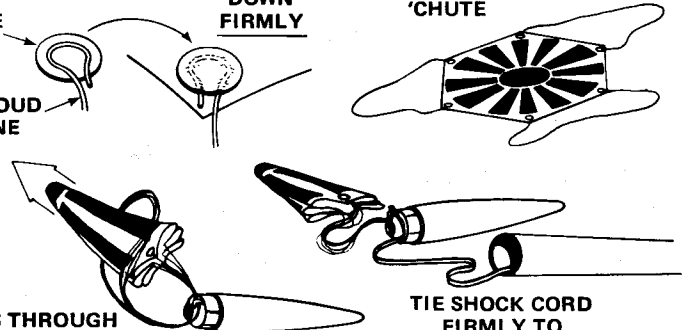

PASS THROUGH AND PULL TIGHT

TIE SHOCK CORD FIRMLY TO NOSE CONE

Cut out the parachute (part M) on its edge lines. Cut three equal lengths of shroud line (part N). Attach line ends to the top of the parachute with tape discs (part O) as shown. Form a small loop inside tape disc on the sticky side. Then carefully press tape disc onto its proper place on the top of the parachute. Firmly press the tape disc into place until both tape disc and parachute material are molded around the shroud line loop. Repeat for other shroud line ends and tape discs. Pass the shroud line loops through the loop on the nose cone. Pass the parachute through the loop ends and pull the lines tight against the nose cone. Tie the free end of the shock cord firmly to the nose cone loop. A square knot or strong double knot should be used.

□ 16

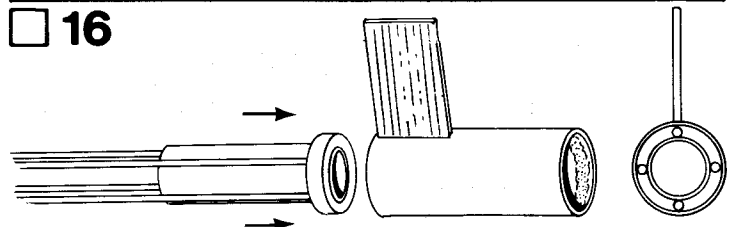

Remove the rubber bands from the dowel units. Rub a small amount of glue into the inside front of the two larger body tubes as shown. Slide one dowel unit part way into each of the two body tubes. Adjust the dowel units so that a dowel is in line with the small fin and push the units in the rest of the way until the ring and tube end are even. Wipe away excess glue.

17

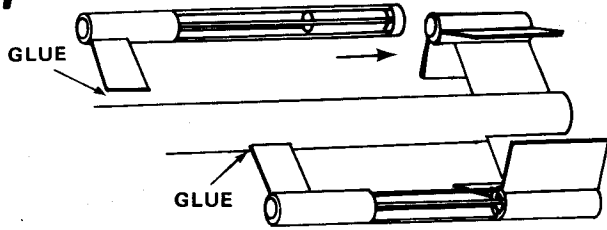

Rub a line of glue onto the root edges of the fins on the dowel units. Slide (do not glue) the rear of the dowel units into the rear fin units until the ring and tube end are even. Adjust the units until the front and rear fins are in line with each other. Press the fins onto the alignment lines and hold in place until the glue sets. Stand the rocket on end and allow the glue to dry completely before proceeding.

18

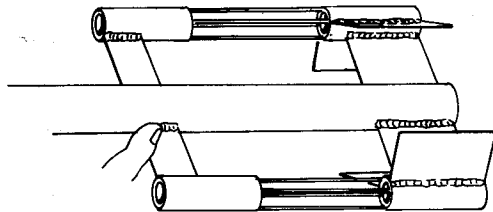

When the glue on the fin joints has dried, apply a glue reinforcement to each fin/body tube joint. Holding the model level, apply a line of glue to both sides of each joint. Smooth out the glue with your finger. Allow the rocket to lay flat while the glue dries.

19

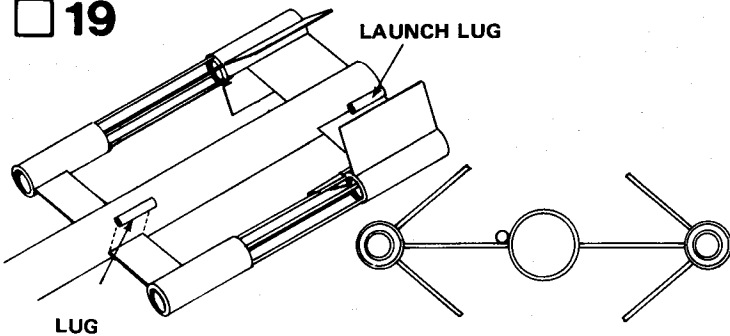

Glue the launch lugs (part P) to the body tube/fin joints as shown. Sight through the launch lugs to see that they are straight. If a launch rod is available, carefully slide the rod through the launch lugs to be sure that they are in line with each other.

20

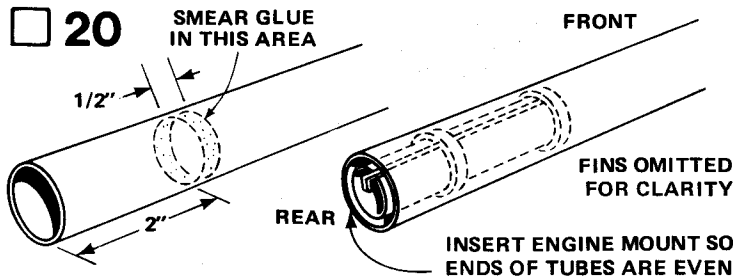

The engine mount unit will be pushed into place so that the rear of the engine mount unit (end with engine hook projecting) is even with the rear of the body tube. Test-fit the engine mount unit several times by smoothly inserting and removing it. Sand if necessary to assure a smooth fit. Once this can be smoothly and easily done, remove the engine mount unit. Apply a ring of glue around the inside of the rear of the main body tube about 2" to 2-1/2" from the end of the tube. Make certain that the engine hook is to the rear and insert the engine mount unit with one

smooth motion. Do not pause, or the glue may "lock" with the engine mount unit in the wrong position.

## PAINTING AND DETAILING

21 USE ROLLED PAPER FOR ROCKET HOLDER

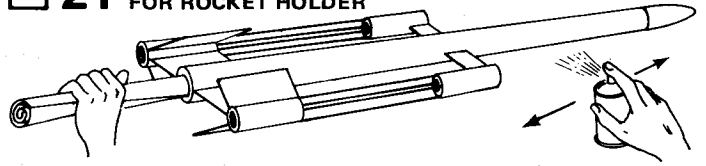

Paint the entire model Aircraft Grey. Follow instructions on the spray can for best results. We recommend spray enamel. Do not paint the model with lacquer paint. Shake can before spraying. Hold the can straight up and spray in long, smooth "strokes". Spray the model with several light, dry mist coats of paint to avoid "runs". Shake can periodically. To obtain a gloss, final coat should be applied slightly heavier. Let this coat dry overnight. Be sure paint is completely dry before applying decals.

## DECAL PLACEMENT

22

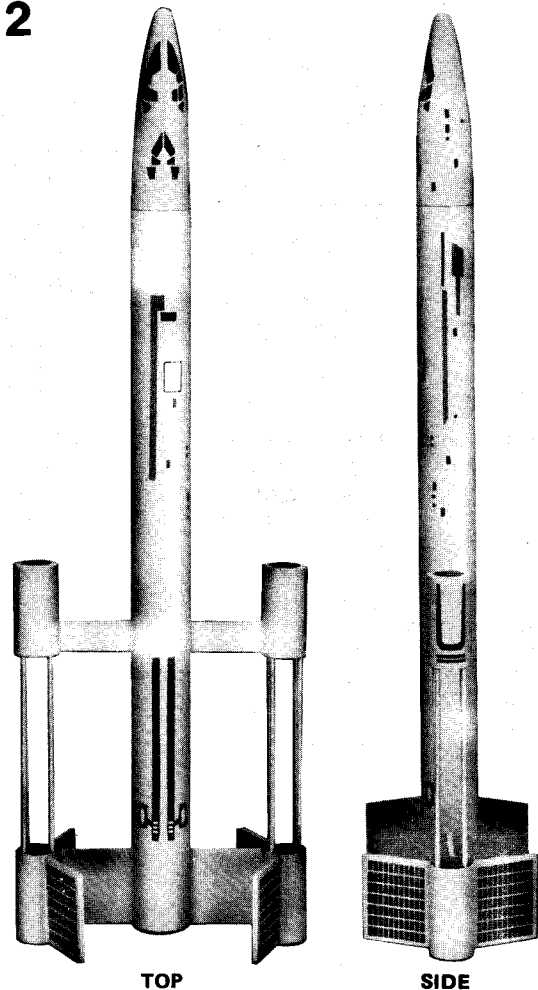

When all paint is dry, apply the decals (part Q) in the positions shown. (A) Cut only one decal at a time from sheet. (B) Submerge decal in lukewarm water until decal slides on backing paper (usually 15 to 30 seconds). (C) Gently slide decal from backing paper onto model. (D) Move decal into exact position and carefully blot away excess water with a soft cloth. (E) If the decal "sticks" before you have it in position, apply water over the decal with a brush. This will permit the decal to be moved. (F) Smooth out all wrinkles and air bubbles before the decal dries. We recommend that the completed model be sprayed with Testor's "Dull-Cote". This is a clear flat spray paint that kills the decal shine and protects the model's finish.

# LAUNCHING COMPONENTS

To launch your rocket you will need the following items:

- An Estes model rocket launching system
  - Flameproof recovery wadding (Estes Cat. No. 2274)
  - Estes A8-3, B4-4, B6-4, B8-5, or C6-5 model rocket engines.
- Use an A8-3 engine for your first flight.

Be sure to follow the HIAA-NAR\* Model Rocket Safety Code when carrying out your model rocket activities.

\*HIAA - Hobby Industry Association of America  
NAR - National Association of Rocketry

## COUNTDOWN CHECKLIST

### T-13

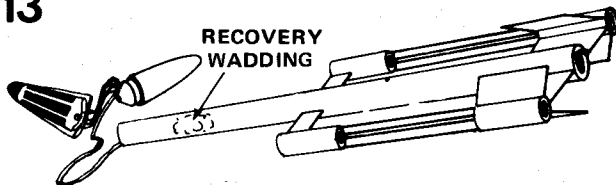

Pack 3 or 4 squares of loosely crumpled recovery wadding into the body tube. Usually this will fill the body tube for a distance equal to about 1-1/2 times its diameter.

### T-12

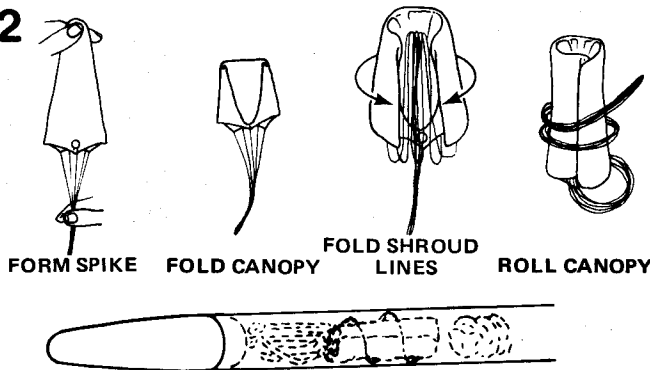

Hold the parachute at its center and pass the other hand down it to form a "spike" shape. Fold this spike in half. Fold shroud lines back along parachute and then back down to lower edge of parachute to reduce length of shroud line "left over". Roll parachute into tube shape to fit easily into body. Any remaining shroud line should be loosely wrapped around parachute. Pack chute into the body tube on top of the wadding. Pack the shroud lines and shock cord in on top of the parachute and slip the nose cone into place. Nose cone should separate easily from rocket body tube, but should not be extremely loose. If fit is too tight, sand inside of body tube and shoulder of nose cone with fine sandpaper. If fit is too loose, add a wrapping of masking tape to the shoulder of the nose cone.

NOTE: DO NOT pack parachute until you are actually ready to launch. For maximum parachute reliability, lightly dust the chute with ordinary talcum powder before each flight, especially in cold weather.

### T-11

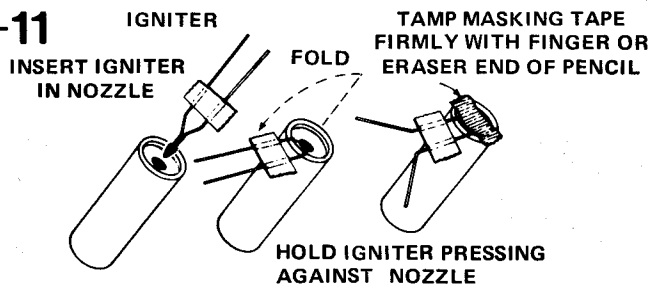

Select an engine and install an igniter as directed in the engine instructions. The engines recommended for use with this rocket are the A8-3, B4-4, B6-4, B8-5, and C6-5 made by Estes. Use an A8-3 engine for your first flight.

### T-10

ENGINE HOOK MUST LATCH SECURELY

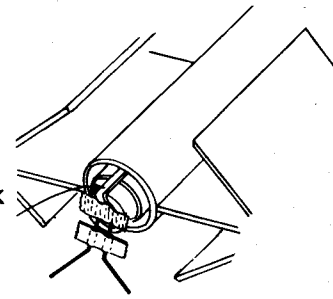

Insert engine into rocket engine mount. Engine hook must latch securely over end of the engine.

### T-9

Disarm the launch panel - REMOVE SAFETY KEY!

### T-8

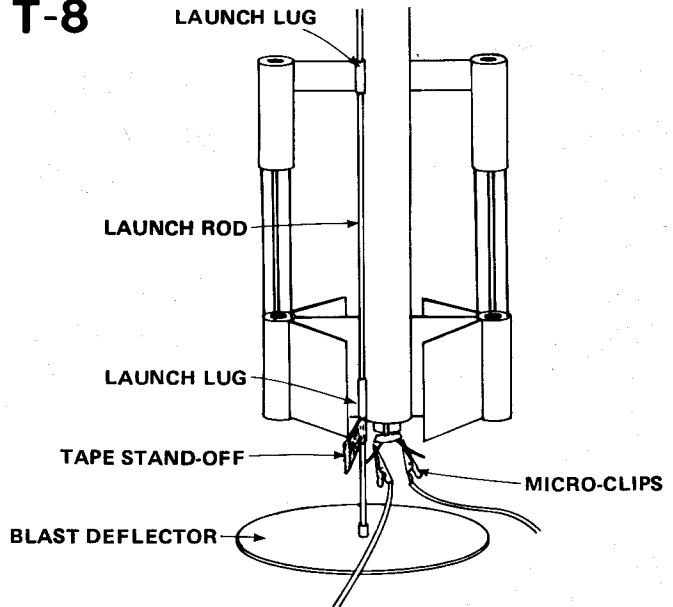

Slide launch rod through rocket launch lug and place rocket on launch pad. Make sure the rocket slides freely on the launch rod. Clean the micro-clips and attach them to the igniter wires. Arrange the clips so they do not touch each other or the metal blast deflector. Attach clips as close to protective tape on igniter as possible.

### T-7

Clear the launch area. Alert recovery crew and trackers. Check for low flying aircraft and unauthorized persons in the recovery area.

### T-6

Arm the launch panel - INSERT SAFETY KEY!

**-5-4-3-2-1-LAUNCH!!**

Repeat Countdown Checklist for each flight.

## MISFIRE PROCEDURE

Disarm the launch panel. Wait one minute before approaching the rocket on the launch pad. Remove the rocket, clean the igniter residue from the nozzle of the engine, and carefully install a new igniter. Repeat the Countdown Checklist.

Failure of the rocket engine to function properly is nearly always caused by a failure to install the igniter correctly. This failure permits the igniter to heat and burn into two pieces without igniting the engine.

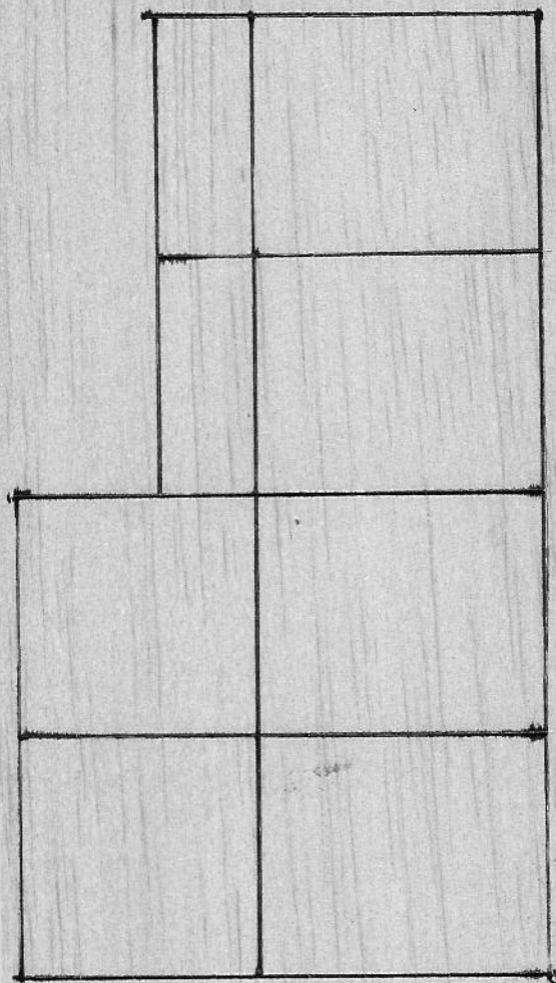

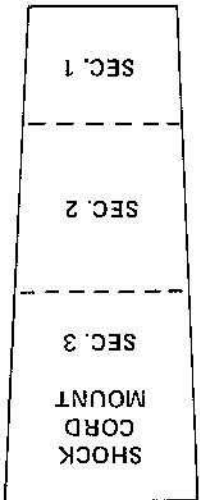
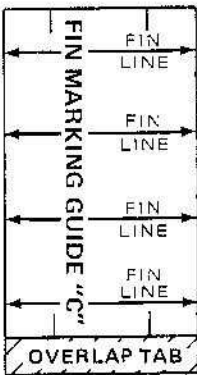
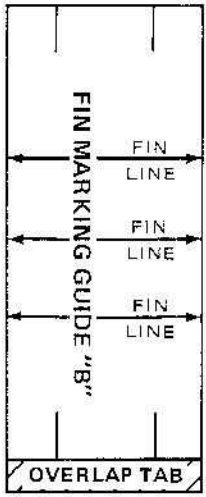

PN83383



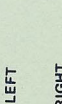
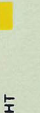
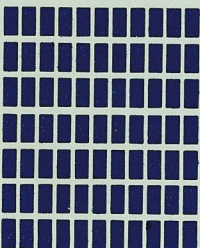
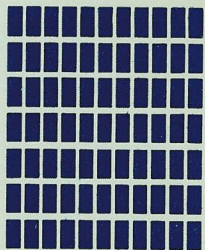
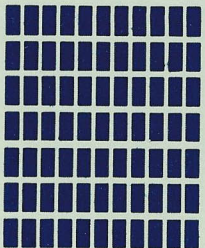

LEFT

RIGHT

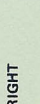
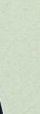

LEFT

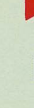

ESTES INDUSTRIES PN 37517

# Scorpius

## FLYING MODEL ROCKET

SKILL LEVEL 3

1 Beginner 2 Intermediate 3 Challenge  
4 Advanced 5 Expert

Length:  
19.20" (48.79cm)

Diameter:  
3.00" (76.2mm)

Weight:  
1.88 oz. (53g)

Engine Types:  
A8-3, B6-4 (First  
Flight), B6-4,  
C6-5, B6-5

- Exotic Space Cruiser
- Die-Cut Balsa Fins
- Plastic Nose Cone
- 3-Color Kit Decal
- 12" Parachute Recovery
- Quick-Release Engine Mount



Flights  
Over  
1,000\*

This is a hobby kit requiring assembly. Recommended for ages 10 to adult. Engines, launch system, glue and finishing supplies are not included. Adult supervision is suggested for those under 12 years of age when flying model rockets.

#1375

 ESTES



ESTES INDUSTRIES  
GREENSBORO, NC 27409 USA