

# MAGNUM™



FLYING MODEL ROCKET #1422

ESTES INDUSTRIES 1295 H STREET PENROSE, CO 81240

## ASSEMBLY TIP

Read all instructions before beginning work on your model. Make sure you have all parts and supplies. Test-fit all parts together before applying any glue. If any parts don't fit properly, sand as required for precision assembly.

## PARTS AND SUPPLIES

Locate the parts shown and lay them out on the table in front of you. In addition to the parts included in the kit you will also need:

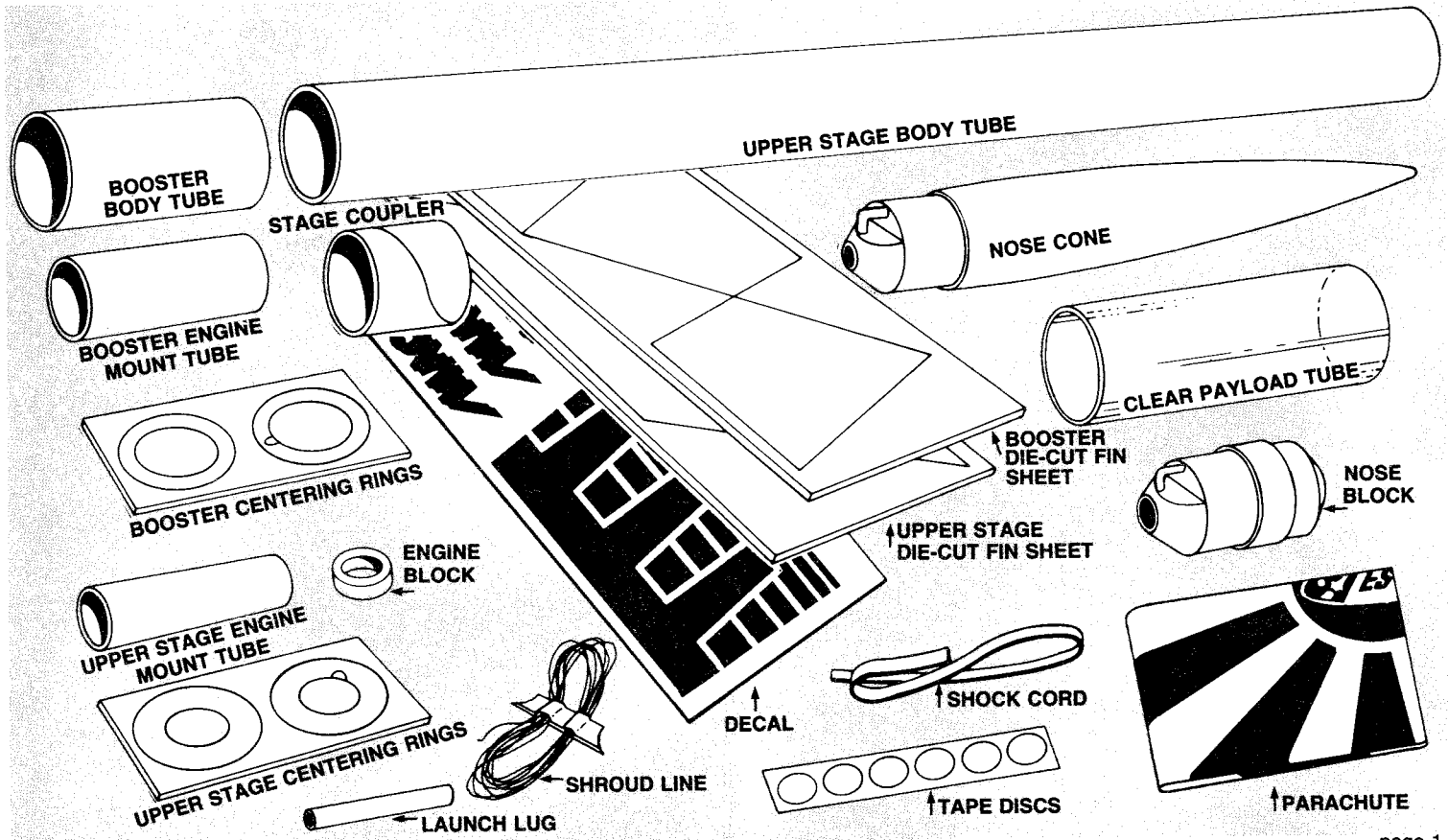
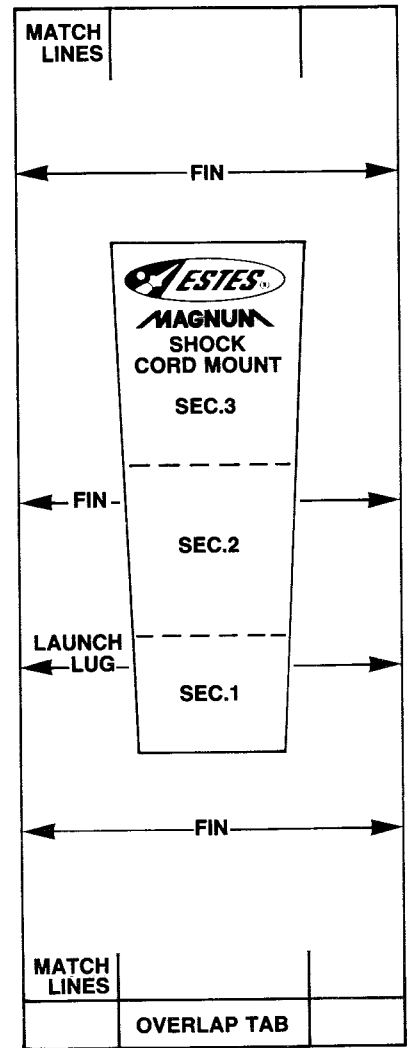
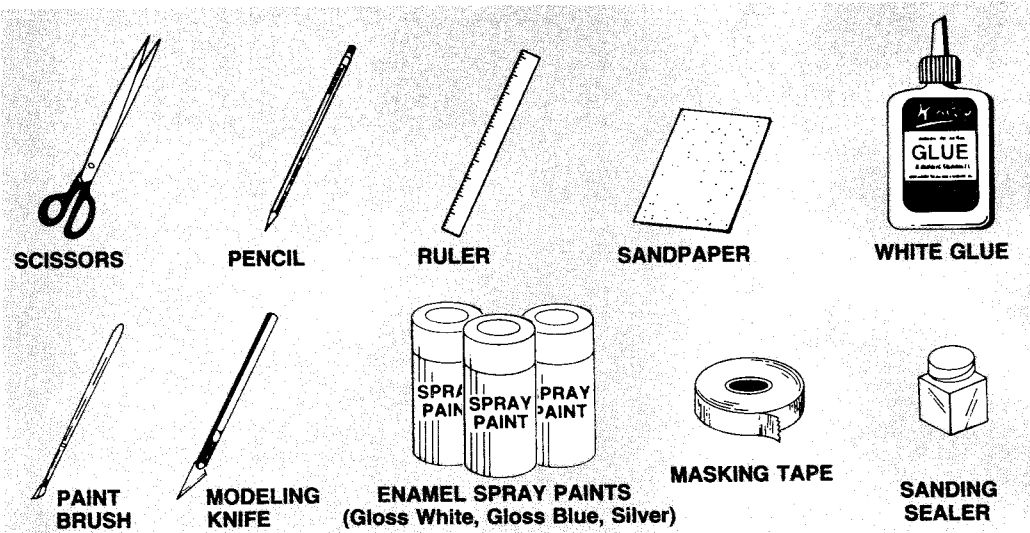

# BOOSTER ASSEMBLY

## 1.

- Mark booster engine mount tube 3/4 inch and 2 inches from one end.
- Remove the centering rings from booster die-cut card. Sand inside edges of rings if necessary for proper fit.
- Slide rings over end of tube and up to 2 inch mark. Apply a bead of glue to both sides of the ring/tube joint.
- Slide second ring onto tube up to 3/4 inch mark and apply a bead of glue as before to both sides of this ring/tube joint. Set assembly aside to dry.

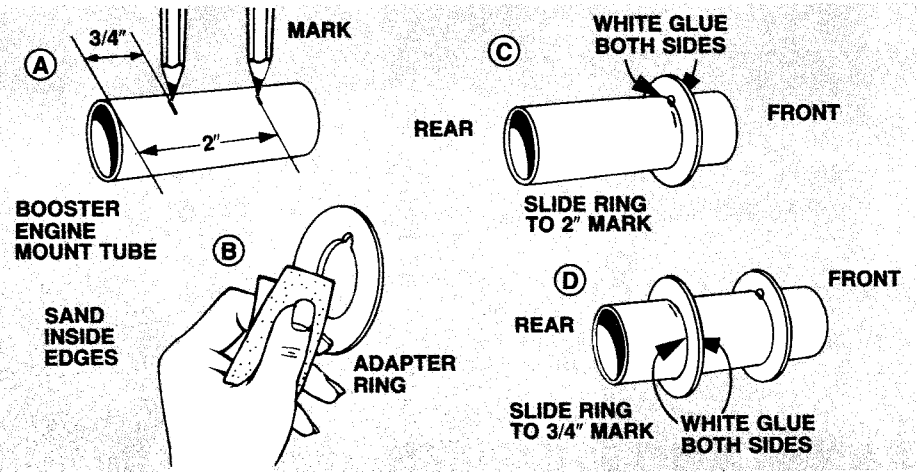

## 2.

- When engine mount is dry, apply a bead of glue around inside of booster body tube.
- Slide engine mount into body tube. Push forward until end of engine mount tube is even with end of body tube. Stand body upright and allow glue to dry.
- Using a piece of scrap balsa for an applicator, apply a bead of glue around the ring/body tube joints.

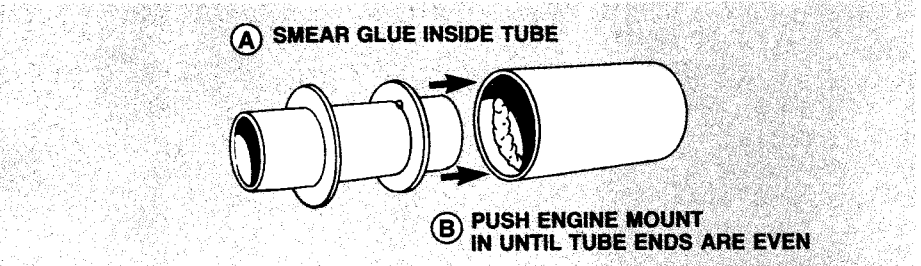

## 3.

- Apply glue around inside one end of booster body tube assembly again.
- Slide stage coupler into booster body assembly as far as it will go against engine mount ring.

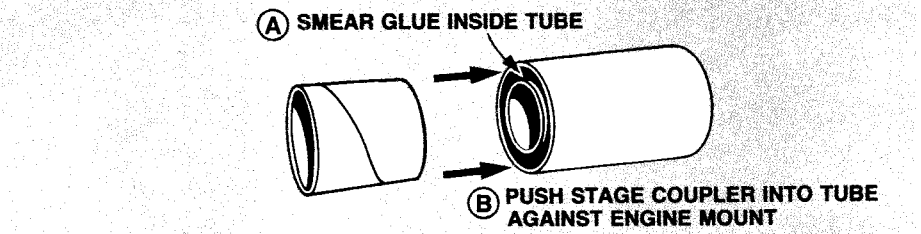

## 4.

- Cut out tube marking guide from front of instructions.
- Wrap guide around the booster body section and tape. Mark tube at arrows. Remove guide and save.
- Slide booster assembly into upper stage body tube and tape tubes together.
- Draw straight lines connecting each pair of marks. Extend lines at least 6 inches up the length of upper stage body. Extend launch lug line the length of tube. Remove tape and upper stage from booster. Set aside upper stage for later assembly.

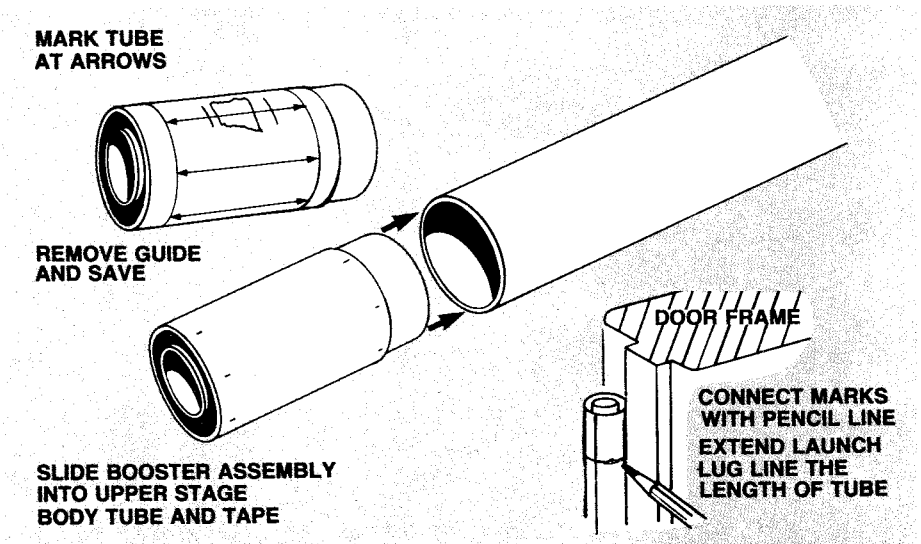

## 5.

- Fine sand booster fin balsa die-cut sheet. Carefully remove fins by freeing edges with sharp knife.
- Stack fins together. Sand all edges smooth.

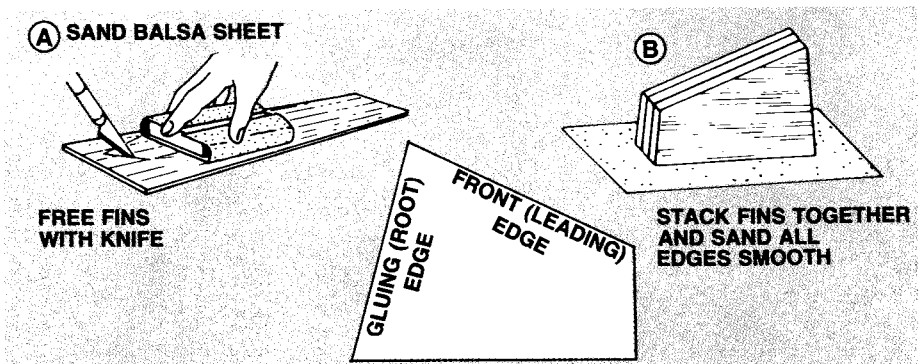

## 6.

- Compare fins to drawing in previous step, to find gluing (root) and front (leading) edges of fins.
- Apply a bead of glue to root edge of each fin. Attach the fin to the booster assembly with fin centered on alignment line and even with bottom of tube. Repeat for each of the other two fins.
- Adjust fins to project straight out from tube. Set assembly aside to dry. Fins must be attached correctly for stable flight!

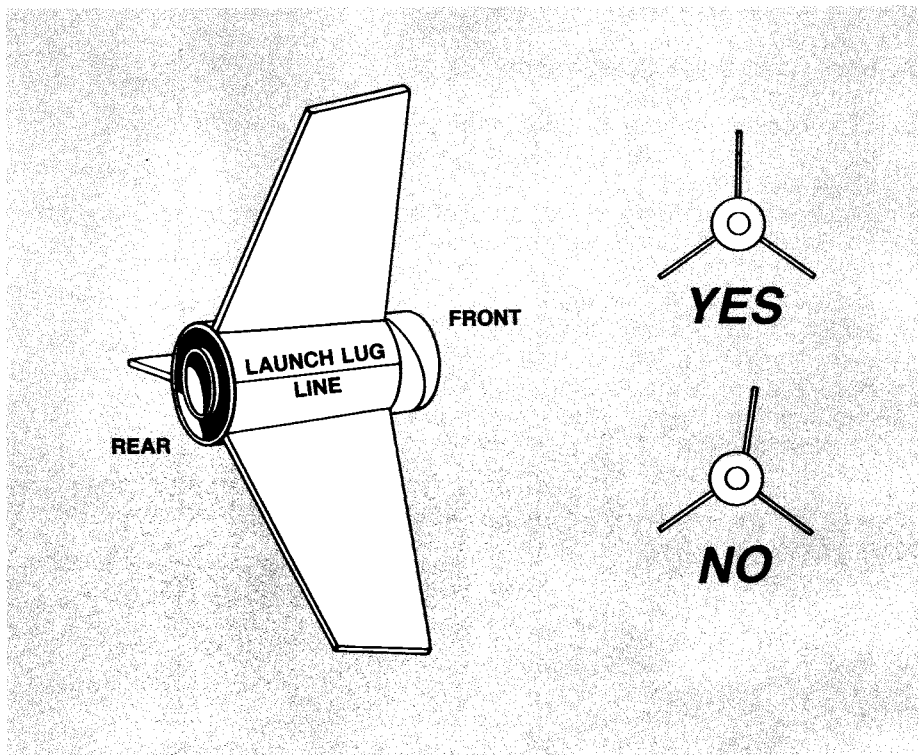

## UPPER STAGE ASSEMBLY

### 1.

- Mark upper stage engine mount tube  $3/4$  inch and  $2\frac{1}{2}$  inches from one end.
- Remove the centering rings from upper stage die-cut card. Sand inside edges of rings if necessary for proper fit.
- Slide rings over end of tube up to  $2\frac{1}{2}$  inch and  $3/4$  inch marks. Apply a bead of glue to both sides of the ring/tube joints.
- Apply a small bead of glue around inside front end of engine mount tube. Slide engine block into front of tube until it is even with end of tube. Remove any excess glue from around engine block with scrap balsa. Set assembly aside to dry.

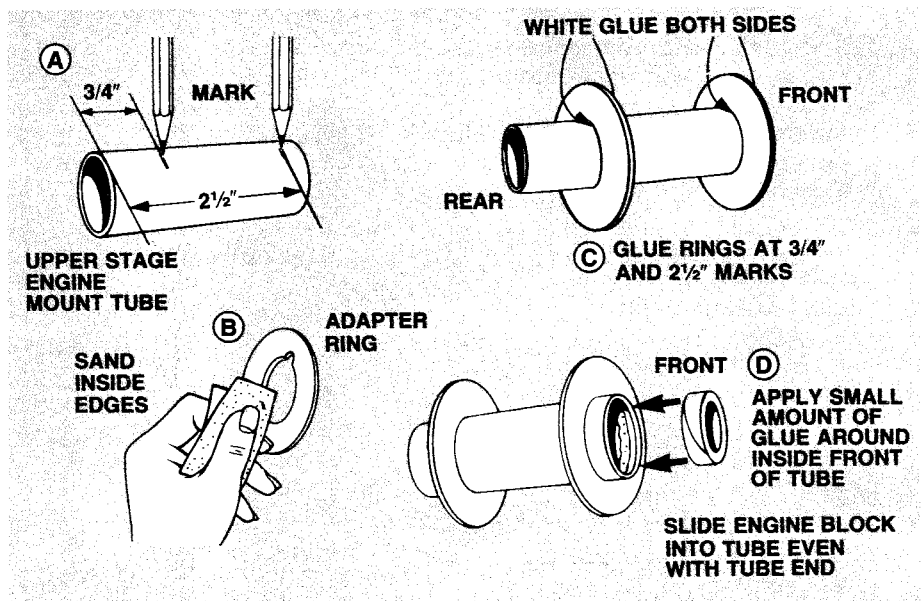

### 2.

- Fine sand upper stage balsa die-cut sheet. Carefully remove fins by freeing edges with sharp knife.
- Stack like fins together. Sand all edges smooth.

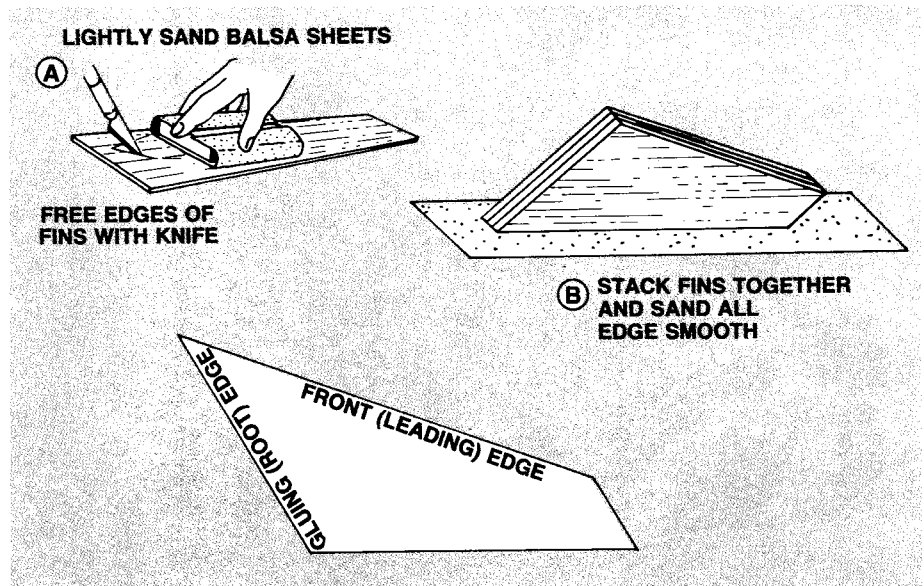

### 3.

- Mark upper stage fin alignment lines  $1\frac{1}{8}$  inch from rear of tube.
- Slide booster stage and upper stage together. Align launch lug lines of upper stage and booster.
- Apply a bead of glue to root edge of a fin. Attach the fin to the upper stage body tube with fin centered on alignment line and even with  $1\frac{1}{8}$  inch mark.
- Adjust fin to project straight out from tube and aligned with booster assembly fin. Apply a piece of masking tape to secure fins together. Repeat gluing procedure for other two fins.

**FINS MUST BE ATTACHED CORRECTLY FOR STABLE FLIGHT!**

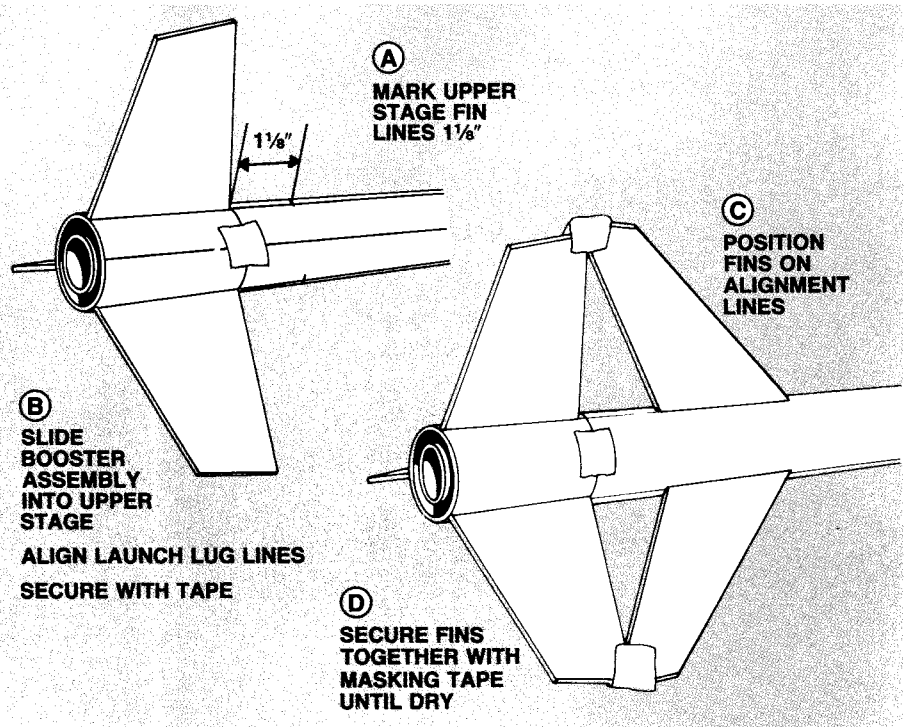

### 4.

- Trim excess plastic from around sides of the nose cone and nose block. Lightly sand seams.
- Wash parts in warm soapy water. Allow to dry thoroughly.

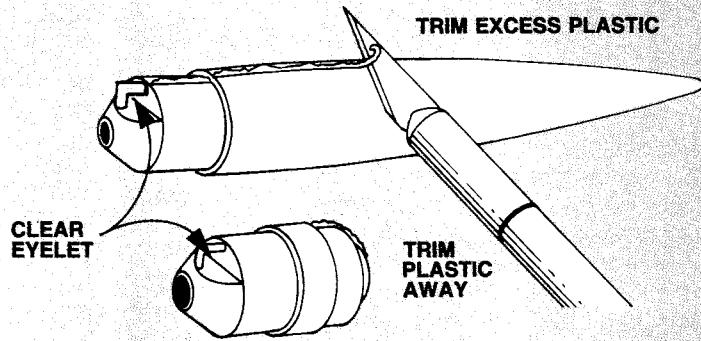

### 5.

- Remove any excess plastic with modeling knife or fine sandpaper from around ends of clear payload tube.
- Sand both ends of payload tube flat. Wash part in warm soapy water. Allow to dry thoroughly.

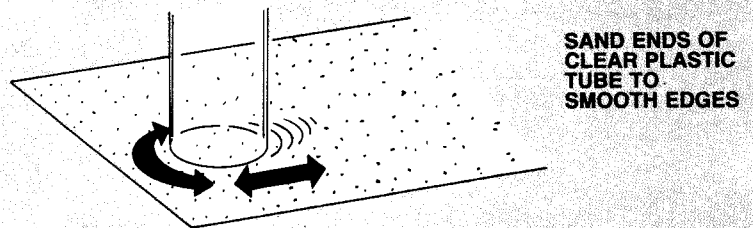

### 6.

- Remove tape from fins and separate upper stage and lower stage.
- Apply a bead of glue around inside rear of upper stage body tube.
- Slide engine mount into tube until end of tubes are even.
- Using a piece of scrap balsa, apply a bead of glue around inside ring/tube joint.

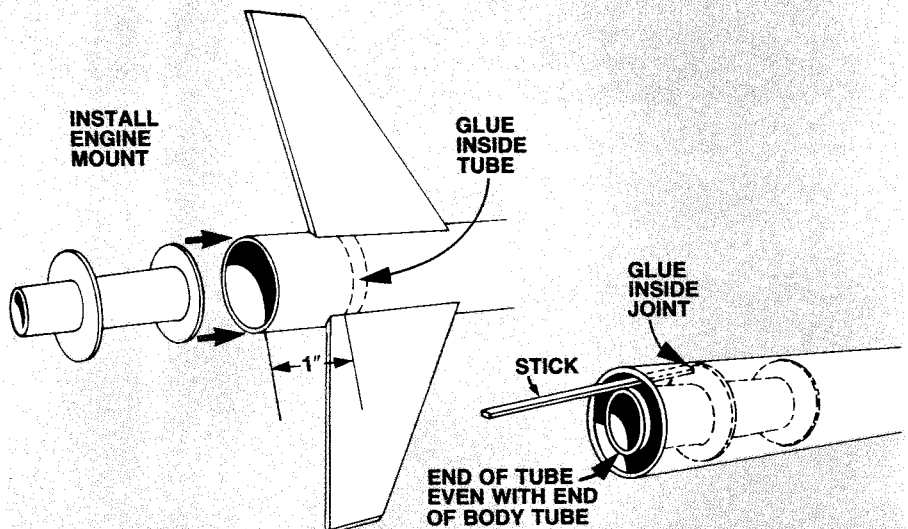

Continued

## 7.

- Cut launch lug into two equal lengths.
- Glue launch lugs centered on launch lug line on upper stage body, one at 1¼ inches and other at 10¾ inches from rear to end of body tube.
- Check alignment of launch lugs.

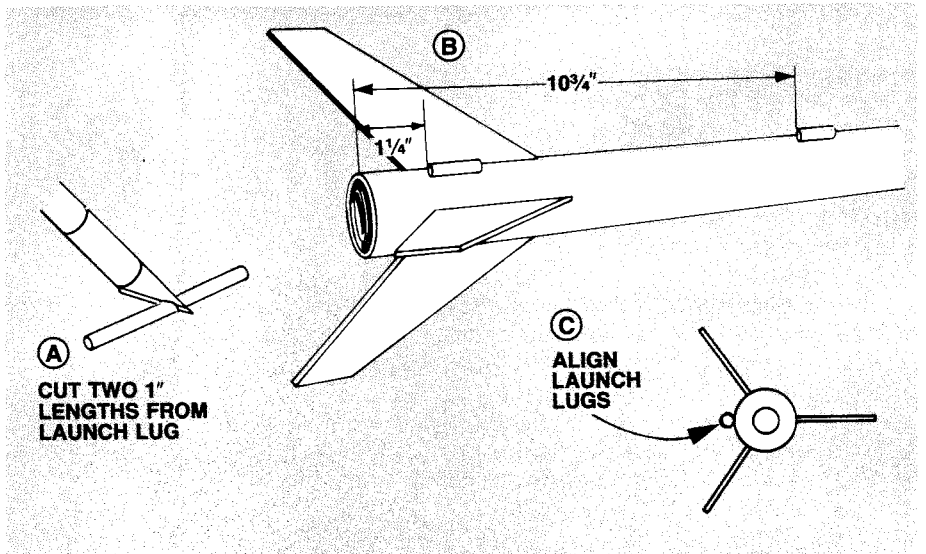

## 8.

- Apply a bead of glue to both sides of each fin/body tube joint on upper stage and booster. Pull your finger along joint to smooth the glue into an even fillet. Fillet the sides of each launch lug.
- Support rocket as shown until glue dries.

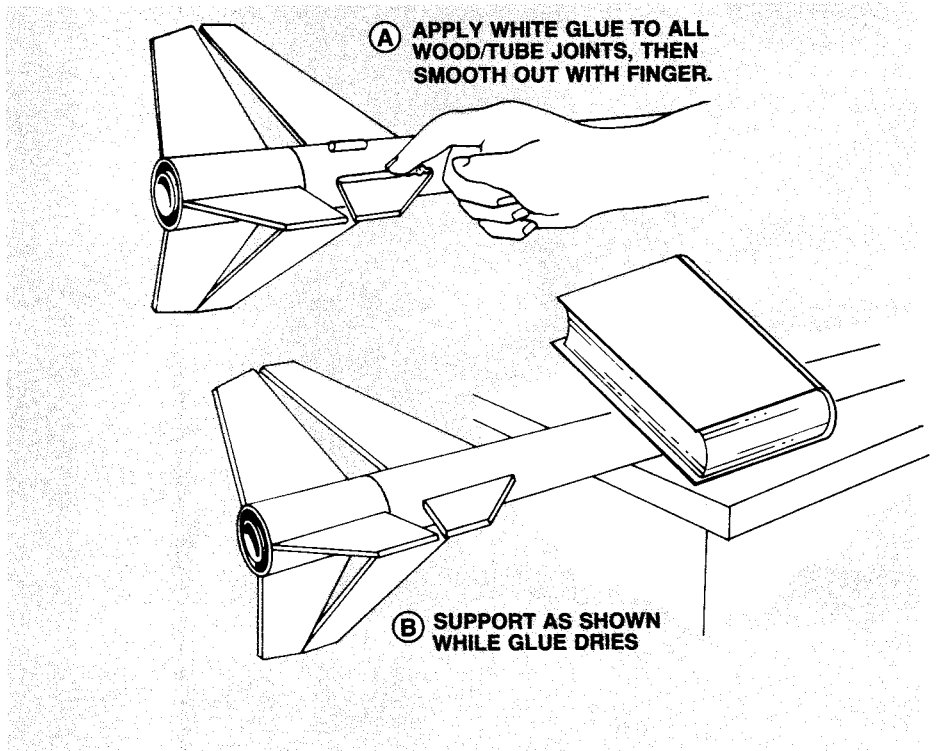

## 9.

- Cut shock cord mount from tube marking guide.
- Crease on dotted lines by folding. Spread glue on section 1 and lay end of shock cord into glue. Fold over and apply glue to back of first section and exposed part of section 2. Lay shock cord as shown and fold mount over again.
- Clamp unit together with fingers until glue sets.

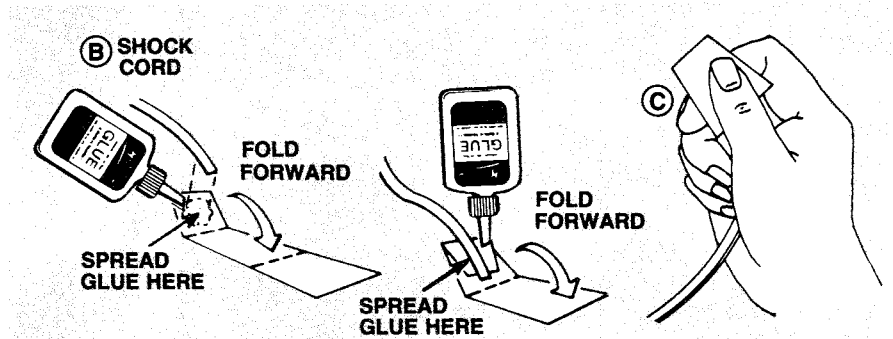

## 10.

- Apply glue to inside front of large body tube to cover an area no less than 1 inch to 2 inches from end. The glue area should be same size as shock cord mount.
- Press mount firmly into glue as shown.
- Hold until glue sets.

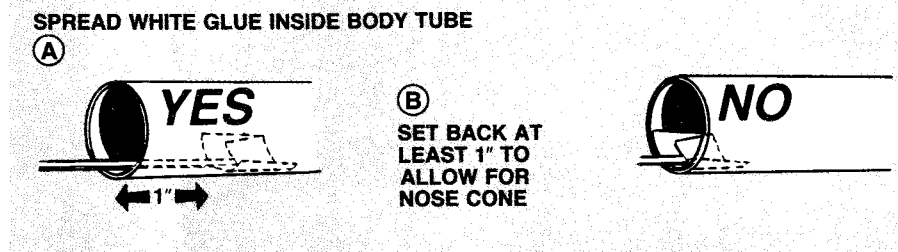

# 11.

- A. Cut out parachute on edge lines
- B. Cut three 23" lengths of shroud line.
- C. Form small loops with shroud line ends and press onto sticky side of tape discs.
- D. Attach tape discs with line ends to top of parachute as shown.
- E. Firmly press tape discs into place until both tape discs and parachute material are molded around shroud line loops.
- F. Assemble payload section, nose block, and nose cone. Pass shroud line loops through eyelet on nose block. Pass parachute through loop ends and pull lines against the nose block.
- G. Tie free end of shock cord to nose block eyelet.

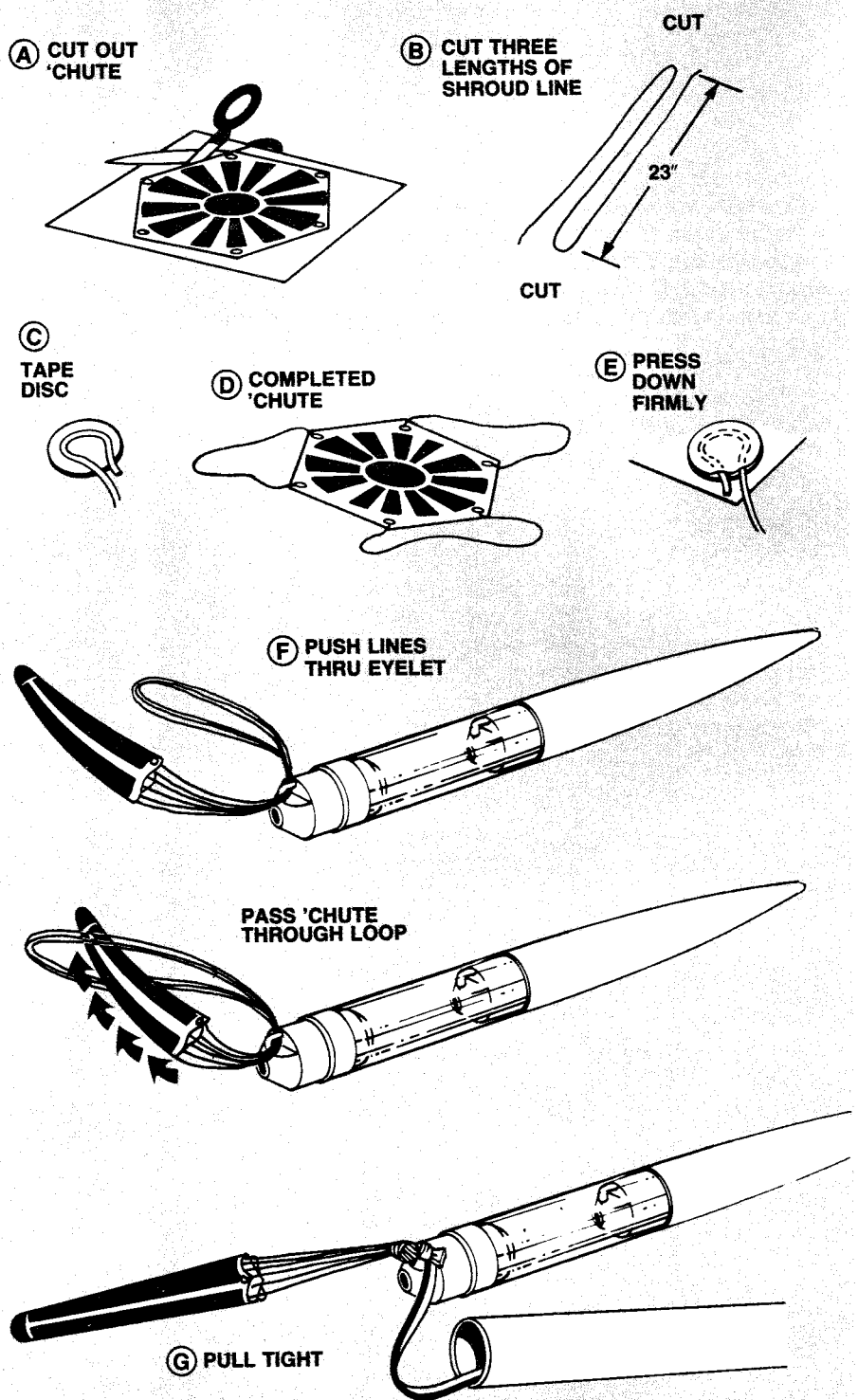

# 12.

- A. Apply sanding sealer to all wood parts with brush.
- B. When sealer is dry, lightly sand all sealed surfaces.
- C. Repeat sealing and sanding until wood grain is filled and smooth.

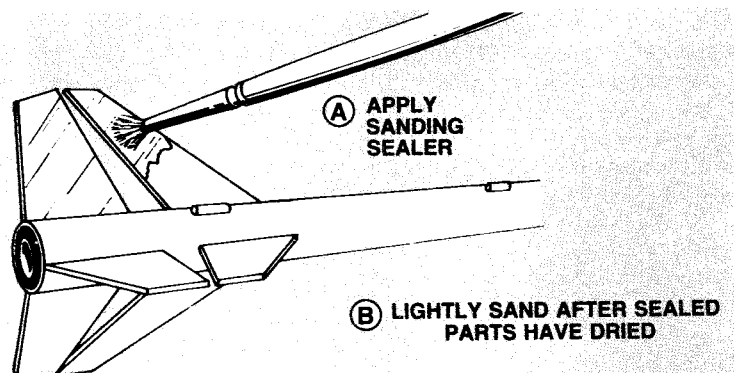

# 13.

- A. When sanding sealer and glue are completely dry paint entire rocket with gloss white enamel.
- B. Follow instructions on spray can for best results.
- C. Let dry over night. Mask off rocket payload section and all upper stage up to 3 inches from nose/block body tube joint. Paint with gloss blue enamel. Remove mask from rocket as soon as paint has set.
- D. Paint booster stage silver enamel. Let dry overnight.
- E. Put booster stage and upper stage together. Rotate booster to align fins to correct position. Mask off one pair of matching fins of upper stage and booster.
- F. Paint the two fins blue. Remove mask from rocket as soon as paint has set.

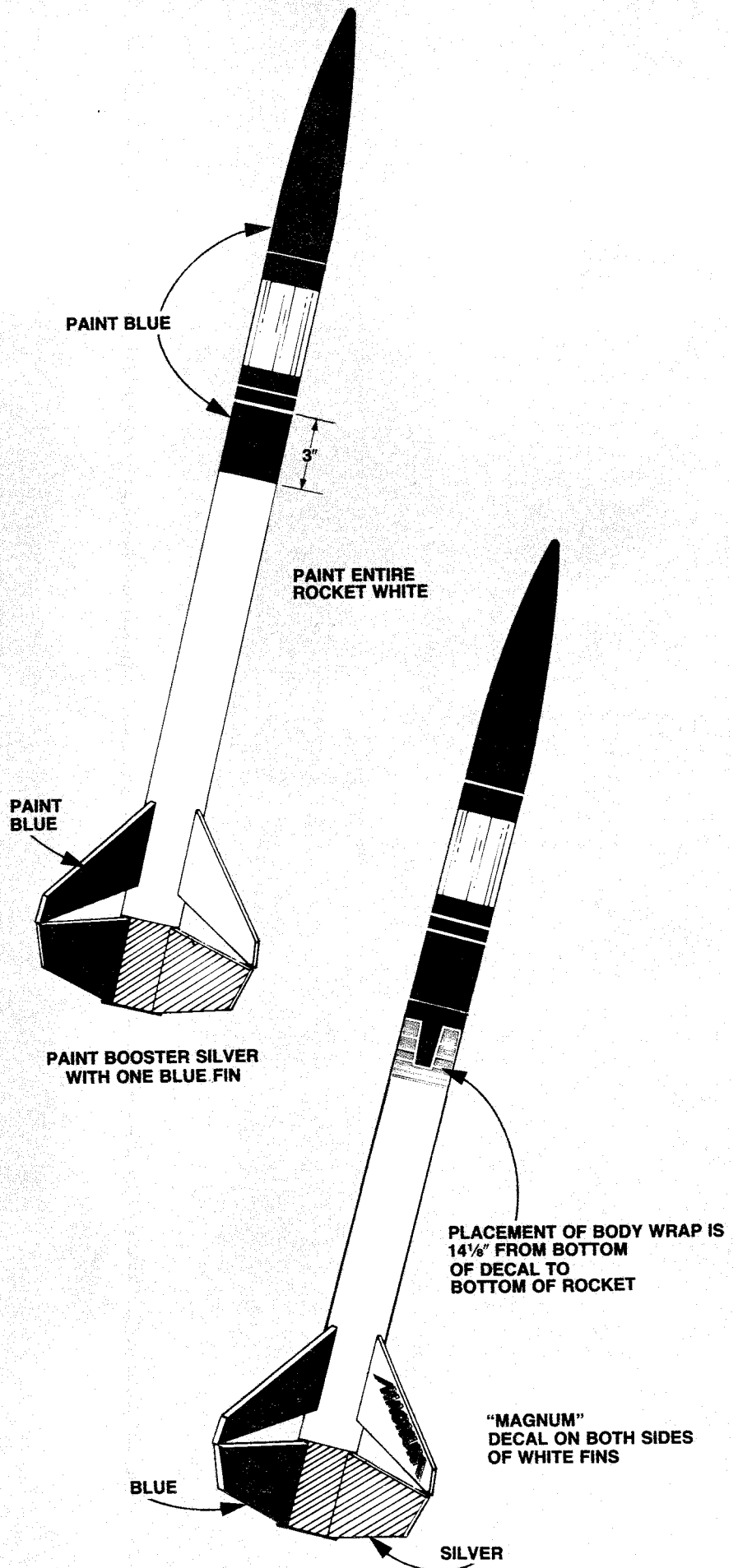

## FINISHING YOUR ROCKET

Apply decals in the positions shown. Cut decals apart, trimming excess clear as close to detail as possible. Dip one decal in lukewarm water for 20 seconds and hold until it uncurls. Slip decal off backing sheet and onto model. Move decal into exact position. Carefully blot away excess water. Smooth out any wrinkles or air bubbles with a soft cloth. When decals are completely dry, spray a coat of clear gloss over model to protect the model's finish and decals.

# ROCKET PREFLIGHT

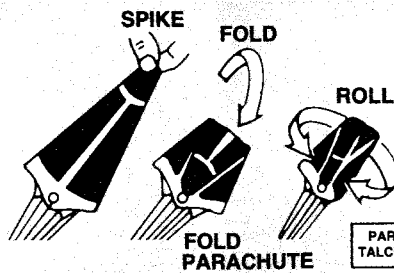
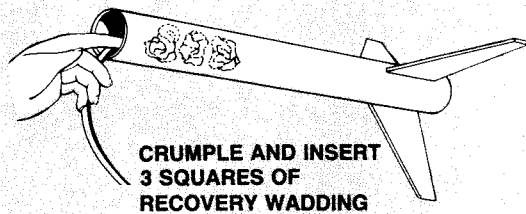

**WRAP LINES LOOSELY AROUND 'CHUTE. INSERT PARACHUTE IN ROCKET. INSTALL PAYLOAD SECTION IN PLACE.**

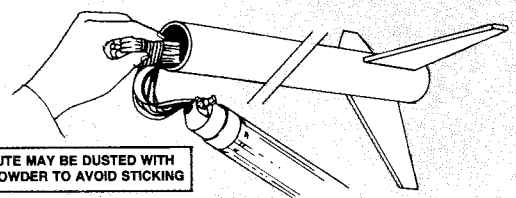

# PREPARE ENGINE

**UPPER STAGE:**

**(A) WRAP TAPE AROUND REAR OF UPPER STAGE ENGINE FOR FRICTION FIT**

**(B) PUSH ENGINE INTO UPPER STAGE UNTIL IT IS AGAINST ENGINE BLOCK**

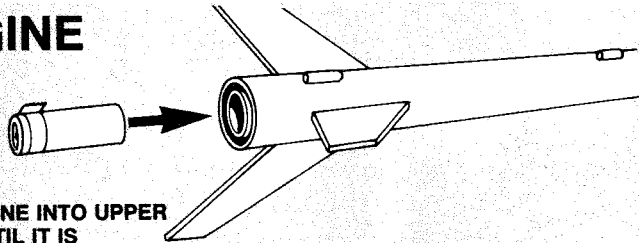

**SINGLE STAGE FLIGHT:**

**(A) FOLLOW BOOSTER STAGE ENGINE PREPARATION BUT USE RECOMMENDED SINGLE STAGE ENGINE.**

**(B) PUSH SINGLE STAGE ENGINE INTO UPPER STAGE UNTIL IT IS AGAINST ENGINE BLOCK.**

**BOOSTER STAGE:**

**(A) SEPARATE THE IGNITERS**

**IGNITER TIP MUST TOUCH PROPELLANT DEEP INSIDE NOZZLE OPENING**

**WRAP TAPE AROUND REAR OF ENGINE FOR FRICTION FIT**

**(F) SLIDE BOOSTER AND UPPER STAGE TOGETHER**

**APPLY AND FIRMLY PRESS TAPE DISC OR MASKING TAPE IN PLACE**

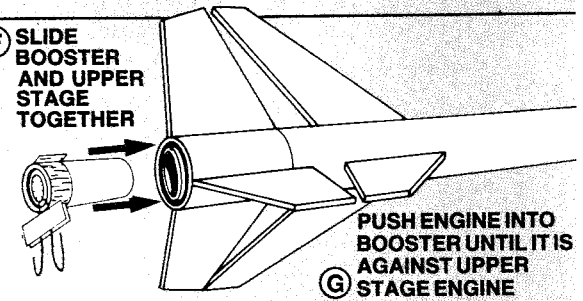
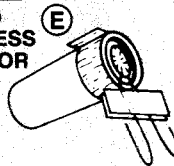
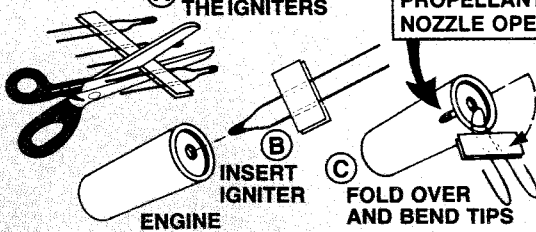

# LAUNCH SUPPLIES

To launch your rocket you will need the following items:

- An Estes Model Rocket Launch System with a Maxi™ Launch Rod.
- Estes Recovery Wadding (No. 2274)
- Recommended Estes Engines: BOOSTER: D12-0
- UPPER STAGE: A8-5, B4-6, B6-6, and C6-7.
- SINGLE STAGE: B4-4, B6-4, B8-5, and C6-5

Use D12-0, C6-7 engines for your first booster flight or B6-4 engine for your first single stage flight to become familiar with your rocket's flight pattern.

Use only Estes products with this set.

# FLYING YOUR ROCKET

Choose a large field away from power lines, tall trees, and low flying aircraft. Try to find a field at least 500 feet square. The larger the launch area, the better your chance of recovering your rocket. Football fields and playgrounds are great.

Launch area must be free of dry weeds and brown grass.

Launch only during calm weather with little or no wind and good visibility.

Don't leave parachute packed more than a minute or so before launch during cold weather. [Colder than 40° Fahrenheit (4° Celsius)].

# MISFIRES

Failure of the model rocket engine to ignite is nearly always caused by incorrect igniter installation. An Estes igniter will function properly even if the coated tip is chipped. However, if the coated tip is not in direct contact with the engine propellant, it will only heat and will not ignite the engine.

When an ignition failure occurs, remove the safety key from the launch control system and wait one minute before approaching the rocket. Remove the expended igniter from the engine and install a new one. Be certain the coated tip is in direct contact with the engine propellant, then tape the igniter leads firmly to base of engine as illustrated above. Repeat the countdown and launch procedure.

# FOR YOUR SAFETY AND ENJOYMENT

Always follow the NAR-HIA\* MODEL ROCKETRY SAFETY CODE while participating in any model rocketry activities.

\*National Association of Rocketry-The Hobby Industry of America page-8

# COUNTDOWN AND LAUNCH

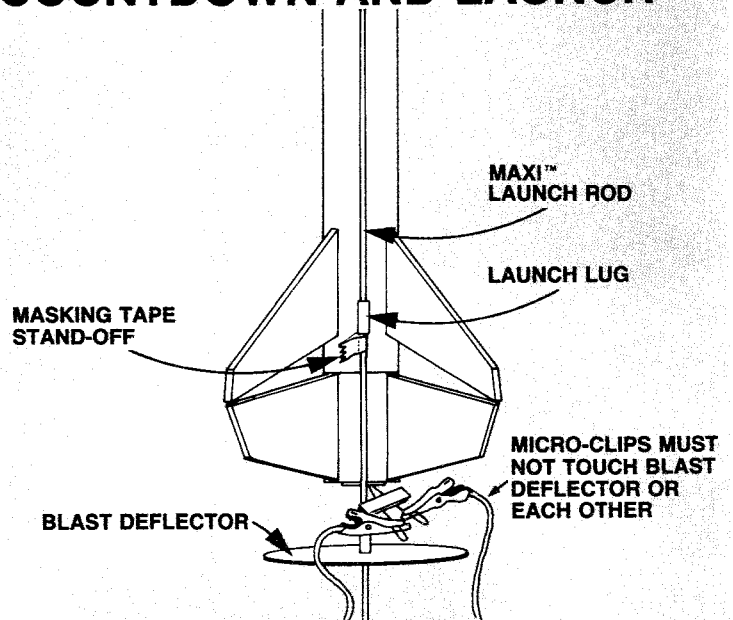

- 10 REMOVE SAFETY KEY to disarm the launch controller.
- 9 Remove safety cap and slide launch lugs over launch rod to place rocket on launch pad. Make sure the rocket slides freely on the launch rod.
- 8 Attach micro-clips to the igniter wires. Arrange the clips so they do not touch each other or the metal blast deflector. Attach clips as close to protective tape on igniter as possible.
- 7 Move back from your rocket as far as launch wire will permit (at least 15 feet).
- 6 INSERT SAFETY KEY to arm the launch controller. Give Audible Countdown 5...4...3...2...1

**LAUNCH!!!** PUSH AND HOLD LAUNCH BUTTON UNTIL ENGINE IGNITES  
Remove safety key—Replace cap on rod.



AY

3

T	F	S
7	8	9
14	15	16
21	22	23
28	29	30

ARY

4	5	6
11	12	13
18	19	20
25	26	27

CH

4	5	6
11	12	13
18	19	20
25	26	27

L

1	2	3
8	9	10
15	16	17
22	23	24
29	30	

6

6	7	8
13	14	15
20	21	22
27	28	29

E

3	4	5
10	11	12
17	18	19
24	25	26

Y

1	2	3
8	9	10
15	16	17
22	23	24
29	30	31

ST

5	6	7
12	13	14
19	20	21
26	27	28

MBER

2	3	4
9	10	11
16	17	18
23	24	25
30		

BER

1	2	
7	8	9
14	15	16
21	22	23
28	29	30

MBER

4	5	6
11	12	13
18	19	20
25	26	27

MBER

2	3	4
9	10	11
16	17	18



F S  
1 2  
8 9  
5 16  
2 23  
9 30  
**1**  
5 6  
12 13  
19 20  
26 27  
5 6  
12 13  
19 20  
26 27  
**2**  
2 3  
9 10  
16 17  
23 24  
30  
7 8  
14 15  
21 22  
28 29  
**3**  
4 5  
11 12  
18 19  
25 26  
**4**  
2 3  
9 10  
16 17  
23 24  
30 31  
6 7  
13 14  
20 21  
27 28  
**5**  
R  
3 4  
10 11  
17 18  
24 25  
**6**  
R  
1 2  
8 9  
15 16  
22 23  
29 30  
R  
5 6  
12 13  
19 20  
26 27  
**7**  
R  
3 4  
10 11  
17 18  
24 25  
31  
**8**



**TODAY**  
1993

M	T	W	T	F	S
<b>JANUARY</b>					
				1	2
4	5	6	7	8	9
11	12	13	14	15	16
18	19	20	21	22	23
25	26	27	28	29	30
<b>FEBRUARY</b>					
					1
1	2	3	4	5	6
8	9	10	11	12	13
15	16	17	18	19	20
22	23	24	25	26	27
<b>MARCH</b>					
1	2	3	4	5	6
8	9	10	11	12	13
15	16	17	18	19	20
22	23	24	25	26	27
29	30	31			
<b>APRIL</b>					
			1	2	3
5	6	7	8	9	10
12	13	14	15	16	17
19	20	21	22	23	24
26	27	28	29	30	
<b>MAY</b>					
					1
3	4	5	6	7	8
10	11	12	13	14	15
17	18	19	20	21	22
24	25	26	27	28	29
31					
<b>JUNE</b>					
	1	2	3	4	5
7	8	9	10	11	12
14	15	16	17	18	19
21	22	23	24	25	26
28	29	30			
<b>JULY</b>					
		1	2	3	
5	6	7	8	9	10
12	13	14	15	16	17
19	20	21	22	23	24
26	27	28	29	30	31
<b>AUGUST</b>					
2	3	4	5	6	7
9	10	11	12	13	14
16	17	18	19	20	21
23	24	25	26	27	28
30	31				
<b>SEPTEMBER</b>					
		1	2	3	4
6	7	8	9	10	11
13	14	15	16	17	18
20	21	22	23	24	25
27	28	29	30		
<b>OCTOBER</b>					
			1	2	
4	5	6	7	8	9
11	12	13	14	15	16
18	19	20	21	22	23
25	26	27	28	29	30
<b>NOVEMBER</b>					
	1	2	3	4	5
8	9	10	11	12	13
15	16	17	18	19	20
22	23	24	25	26	27
29	30				
<b>DECEMBER</b>					
		1	2	3	4
6	7	8	9	10	11
13	14	15	16	17	18
20	21	22	23	24	25
27	28	29	30	31	

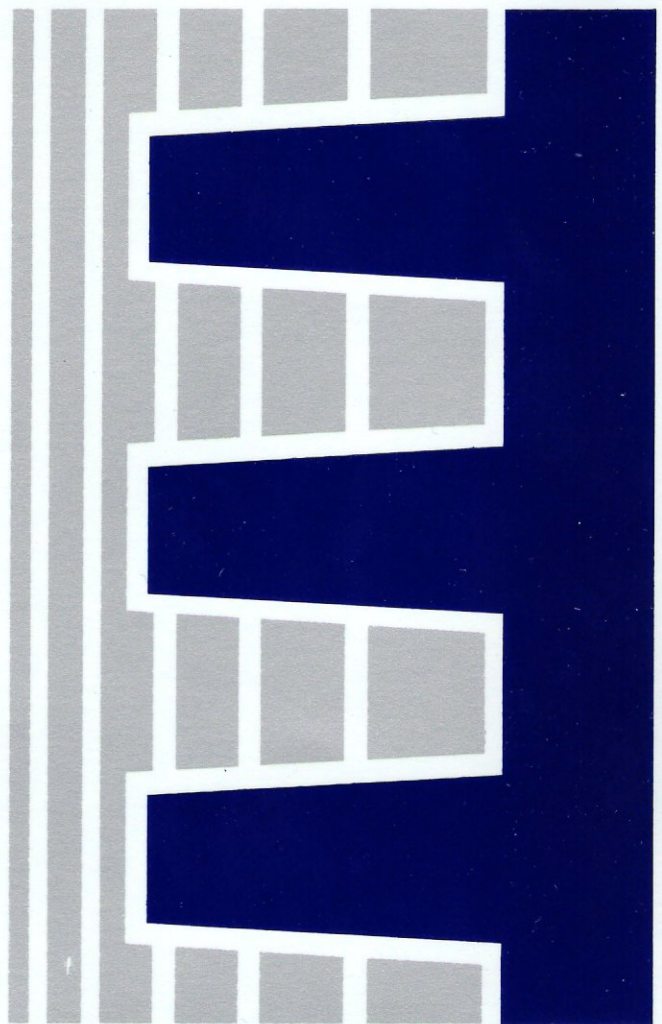

**MAGNUM**  
**MAGNUM**  
**MAGNUM**  
**MAGNUM**

## Estes Magnum Parts List

Refer to parts list illustration in the plans.

Booster Body Tube	BT-60, 2.75" length
Upper Stage Body Tube	BT-60, 18" length
Booster Engine Mount Tube	BT-50, 2.75" length
Stage Coupler	JT-60
Booster Centering Rings	CR 50-60
Clear Payload Tube	CBT-60, 5" length
Booster Die-Cut Fin Sheet	1/8" thick
Upper Stage Die-Cut Fin Sheet	1/8" thick
Nose Block	NB-60 (provides 7/16" to total length of rocket.) (See scanned nosecone.tif)
Upper Stage Engine Mount Tube	BT-20, 2.75" length
Engine Block	EB-20
Upper Stage Centering Rings	CR 20-60
Launch Lug	3/16" X 2"
Parachute	24"