



WASP

FLYING MODEL ROCKET

SKILL LEVEL 2

1-Beginner 2-Intermediate 3-Craftsman
4-Advanced 5-Expert

- Scale-Like Appearance
- "D" Engine Power
- Streamer Recovery
- Plastic Nose Cone
- Die-Cut Balsa Fins

Length: 16.4 in. (41.7 cm)

Dia: 1.325 in. (33.7 mm)

Weight: 1.8 oz. (48.5 g)

Engine Types:

D12-3 (First Flight)

D12-5

**FLIGHTS
UP TO
1200
FEET!**

Recommended for ages 10 to adult.
Adult supervision is suggested for those
under 12 years of age when flying model
rockets. This is a hobby, not a science.

THE WASP

SKILL LEVEL 2 - Recommended for Intermediate Rocketeers.



A DAMON COMPANY

ESTES INDUSTRIES
PENROSE, CO 81240 USA

INCHES
1
2
3
4
5
6
7
8
9
10

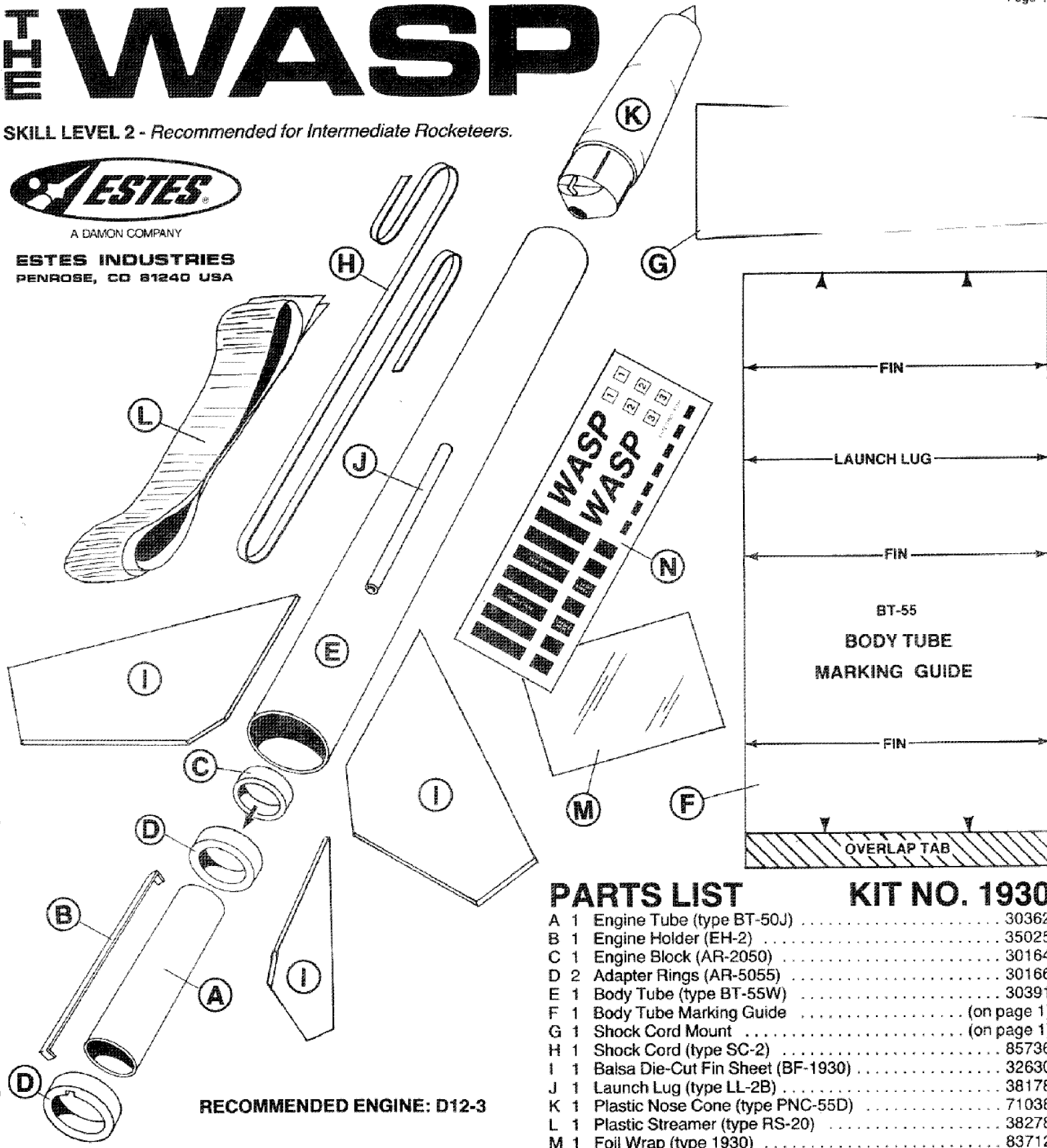

RECOMMENDED ENGINE: D12-3

PARTS LIST

KIT NO. 1930

A	1	Engine Tube (type BT-50J)	30362
B	1	Engine Holder (EH-2)	35025
C	1	Engine Block (AR-2050)	30164
D	2	Adapter Rings (AR-5055)	30166
E	1	Body Tube (type BT-55W)	30391
F	1	Body Tube Marking Guide	(on page 1)
G	1	Shock Cord Mount	(on page 1)
H	1	Shock Cord (type SC-2)	85736
I	1	Balsa Die-Cut Fin Sheet (BF-1930)	32630
J	1	Launch Lug (type LL-2B)	38178
K	1	Plastic Nose Cone (type PNC-55D)	71038
L	1	Plastic Streamer (type RS-20)	38278
M	1	Foil Wrap (type 1930)	83712
N	1	Decal (type KD-1930)	37245

BEFORE YOU START

Read each step and study the accompanying drawings before doing any of the work called for in that step. Make sure you have all parts and materials. Check off each step as you complete it. Always test-fit parts together before applying glue. It will sometimes be necessary to sand edges of rings, tubes, etc. to obtain proper fit. If you are in doubt about the relative size or location of some parts, refer back to this exploded view drawing for clarification. Adequate glue joints are very important for a flying model rocket. Follow the instructions carefully in this report.

TOOLS AND MATERIALS

In addition to the parts included in this kit you will need: Scissors, pencil, ruler, fine or extra-fine grit sandpaper, sanding sealer, a medium-size modeling paint brush, modeling knife with sharp blade, gloss white and gloss yellow enamel spray paint, Testor's Gloss Cote, and household white glue or resin glue (Elmer's, Titebond, or similar). Other types of glue or cement are not recommended.

For easy and positive alignment of the fins on your model, we recommend the use of Estes' Fin Alignment Guide, Part No. 2231.

ASSEMBLY INSTRUCTIONS

1

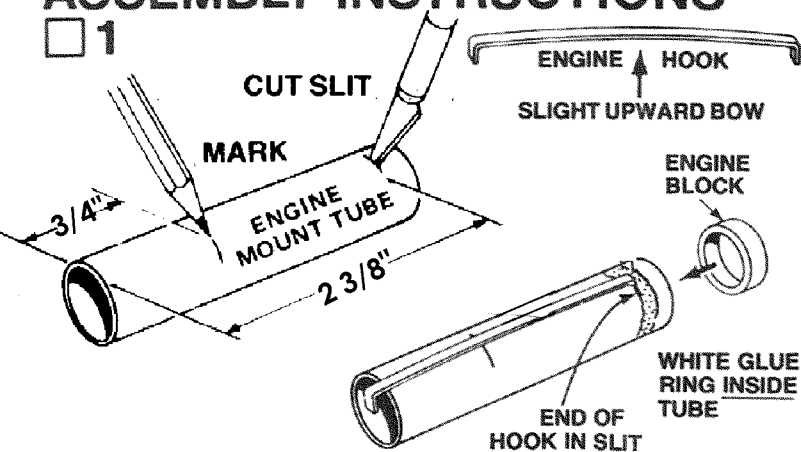

Mark the engine mount tube (part A) at $3/4$ " and $2-3/8$ " from one end. Cut a $1/8$ " long slit at the $2-3/8$ " mark. Gently bend the engine hook (part B) so that it bows upward very slightly in the middle. (Study the drawing—Don't bend the wrong way.) Insert one end of the engine hook into the slit in the tube. Run a line of glue inside the front end of the engine tube and slide the engine block (part C) up to the end of the engine hook.

2

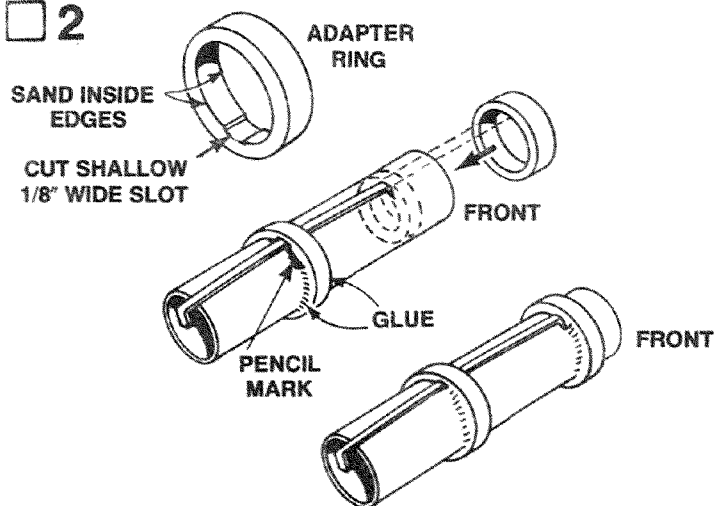

Sand the inside edges of the two adapter rings (part D) to remove burrs. The rings should slide easily onto the engine mount tube. Cut a very shallow $1/8$ " wide slot inside one adapter ring so it will fit over the engine hook. Slip the ring onto the front end of the engine mount tube and slide it down to the $3/4$ " mark. Make sure the engine hook runs straight down the tube. Apply glue around the front end of the engine mount tube and slide the remaining adapter ring into place (front of ring up against end of engine hook), now apply glue to both sides of each adapter and allow assembly to dry.

3

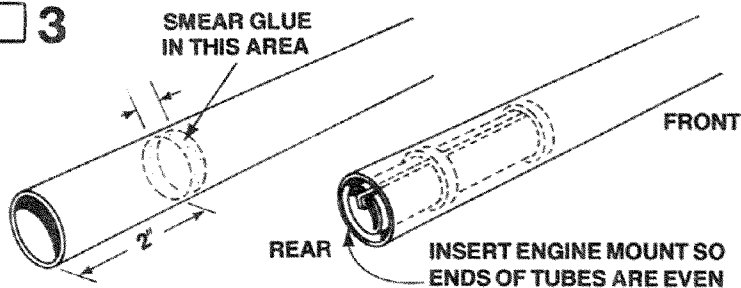

The engine mount unit will be pushed into place so that the rear of the engine mount unit (end with engine hook projecting) is even with the rear of the body tube. Test-fit the engine mount unit several times by smoothly inserting and removing it. Once this can be smoothly and easily done, remove the engine mount unit. Apply a ring of glue around the inside of the rear of the main body tube (part E) about 2" to $2-1/2$ " from the end of the tube. Make certain that the engine hook is to the rear and insert the engine mount unit with one smooth motion. Do not pause, or the glue may "lock" with the engine mount unit in the wrong place.

4

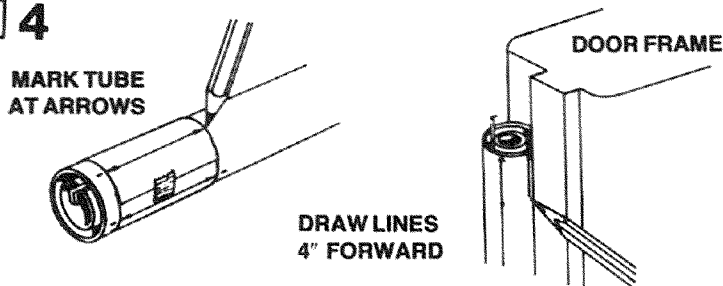

Cut out the body tube marking guide from the instruction sheet, page 1 (part F) and wrap it around the body tube. Place the tube marking guide so that the engine hook lines up with the launch lug line (arrow point). Mark the body tube at each of the arrow points. Draw straight lines connecting each pair of marks. A door frame inside edge can be used as a guide as shown. Extend the fin lines about 4" forward from the rear of the tube, and the launch lug line, 7" up the tube.

5

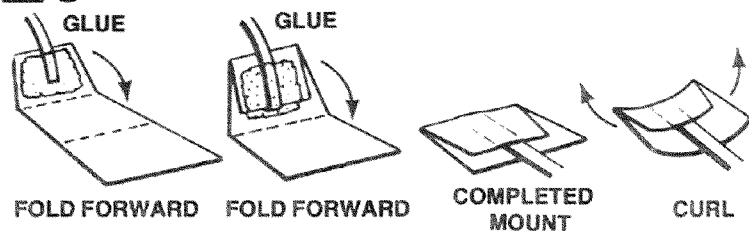

Cut out the shock cord mount (part G). Fold on dotted lines, then unfold and apply glue to Section 1. Lay the end of the shock cord (part H) into the glue. Fold over and apply glue to the back of Section 1 and the exposed portion of Section 2. Fold again to complete mount. Curl the edges of the mount up so it will match the contour of the body tube and hold with your fingers until the glue sets.

6

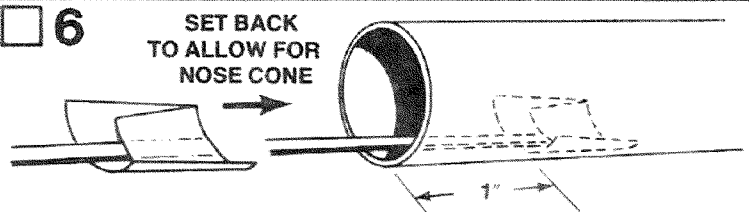

Use a finger or stick to apply glue to the inside of the front of the body tube, 1" to 2" from the front of the tube. Press the shock cord mount firmly into position in the glue far enough from the front edge of the tube to allow clearance for the nose cone to fit into place. To insure a good bond use a stick or your finger to smear a film of glue over the mount and surrounding area in the body tube.

7

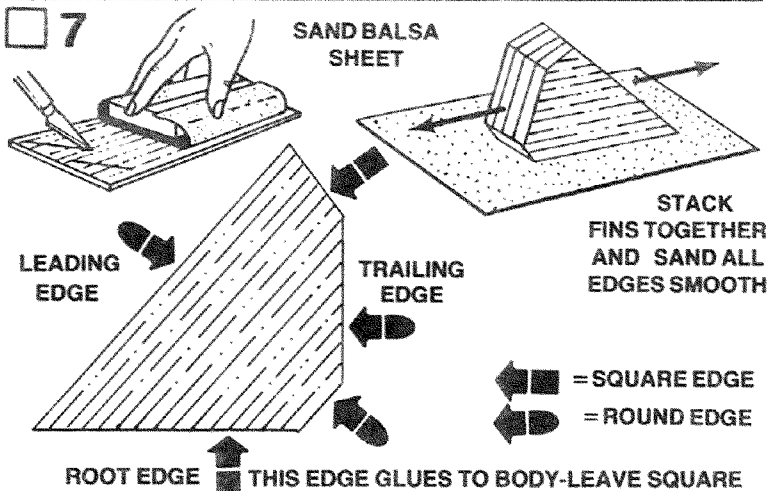

Fine-sand the balsa die-cut sheet (part I). Free the fin edges with a sharp knife, then carefully remove the die-cut fins from the sheet. Stack fins together as shown and sand all four sides as illustrated. Lightly sand both sides of each fin. Sand the leading edge, and trailing edge of each fin to make them round. Leave the root (body) edge and tip edge sanded "flat". The root edge may be identified by careful comparison with the drawings.

□ 8

RUB A LINE OF WHITE GLUE INTO ROOT EDGE OF EACH FIN



Rub a line of glue into the root edge of each fin and allow to dry. Glue the fins to the main body on the fin alignment lines drawn in step 4. Refer to the illustration to be sure you position the fins correctly. The rear edge of each fin should be even with the rear edge of the body tube. Adjust the fins so they project straight away from the body tube. Do not set the rocket on its fins while the glue is wet.

□ 9

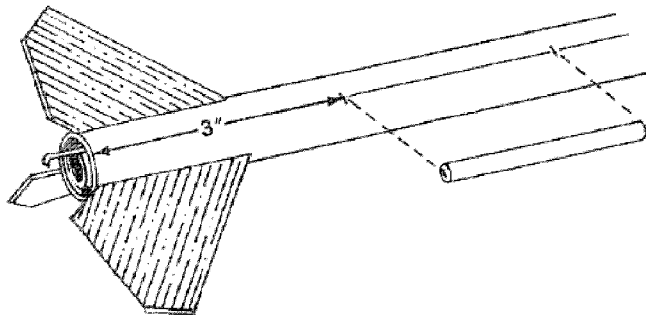

Glue launch lug (part J) to rocket body tube on the launch lug line. The rear of the launch lug should be 3" from the rear of the rocket body tube. Align the launch lug straight along the body.

□ 10

APPLY THIN LINE OF GLUE TO JOINT

THEN SMOOTH OUT WITH FINGER

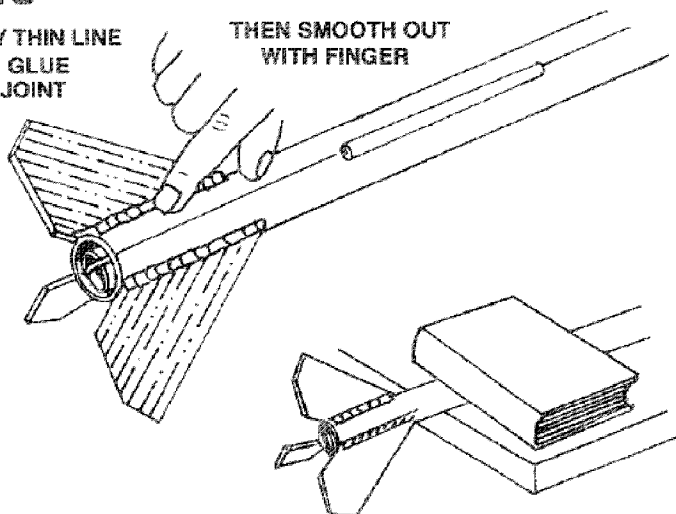

When the glue on the fin and launch lug joints has dried, apply a glue reinforcement to each fin/body tube joint. Holding the model level, apply a line of glue to both sides of each fin joint and on both sides of the launch lug. Smooth out the glue with your finger. **IMPORTANT**—Support rocket on table edge as shown until the glue dries.

□ 11

CLEAR EYELET

TRIM EXCESS PLASTIC

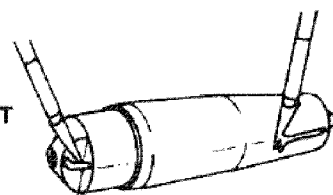

Trim or sand any excess plastic from around the sides of the nose cone (part K). Use a sharp knife to remove any excess plastic from the inside of the molded eyelet at the rear of the nose cone. Wash the nose cone with lukewarm soapy water, rinse well, and dry.

□ 12

TIE END OF SHOCK CORD TO NOSE CONE LOOP

TIE STREAMER TO CENTER OF SHOCK CORD

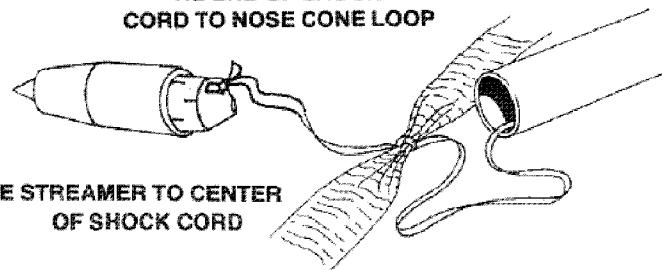

After the glue on the rocket has dried enough so it can be safely handled, tie the free end of the shock cord to the nose loop. Tie the center of the streamer (part L) to the center of the shock cord.

□ 13

COAT WITH SANDING SEALER

SAND LIGHTLY BETWEEN COATS

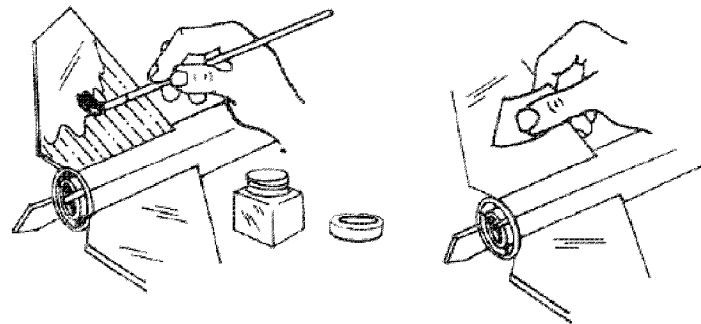

When all glue on the outside of the body is dry, prepare the model for painting. Apply at least two coats of sanding sealer to all wood parts. Let dry and sand lightly between coats. Do this until the tiny holes in the wood are filled and everything looks and feels smooth.

□ 14

REMOVE NOSE CONE AFTER WHITE IS DRY.

USE ROLLED PAPER FOR ROCKET HOLDER

SPRAY BODY GLOSS YELLOW.

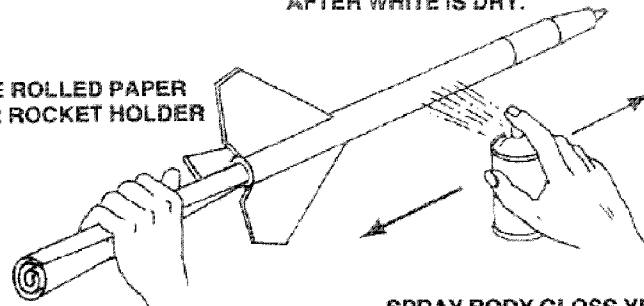

After the sanding sealer is completely dry, paint the entire model gloss white. Follow instructions on the spray can for best results. We recommend spray enamel. Do not paint the model with lacquer paint. Shake can before spraying. Hold the can straight up and spray in long, smooth "strokes". Spray the model with several light, dry mist coats of paint to avoid "runs". Shake can periodically. To obtain a gloss, final coat should be applied slightly heavier. When the white is dry, remove the nose cone and paint the body gloss yellow.

Let this coat dry overnight. Be sure paint is completely dry before applying decals.

15 DECAL PLACEMENT

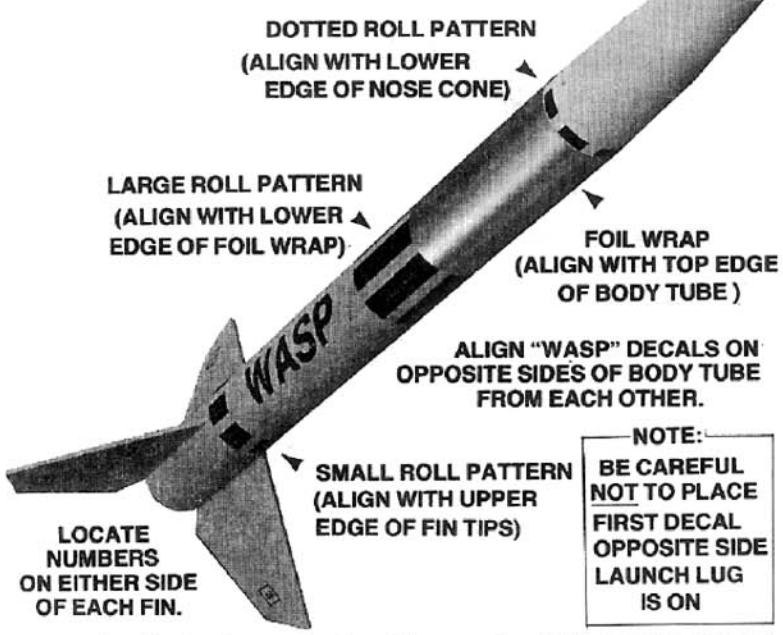

When all paint is dry, apply the foil wrap (part M) and the decals (part N) in the positions shown. Apply foilwrap first. Do not put foil wrap in water (A) Cut only one decal at a time from sheet. (B) Submerge decal in lukewarm water until decal slides on backing paper (usually 15 to 30 seconds). (C) Gently slide decal from backing paper onto model. (D) Move decal into exact position and carefully blot away excess water with a soft cloth. (E) If the decal "sticks" before you have it in position, apply water over the decal with a brush. This will permit the decal to be moved. (F) Smooth out all wrinkles and air bubbles before the decal dries. We recommend that the completed model be sprayed with Testor's "Gloss Cote". This is a clear gloss spray paint that protects the model's finish.

LAUNCHING COMPONENTS

- To launch your rocket you will need the following items:
- An Estes model rocket launching system
 - Flame resistant recovery wadding (Estes Cat. No. 2274)
 - Estes D12-3 model rocket engine.

Be sure to follow the HIAA-NAR* Model Rocket Safety Code when carrying out your model rocket activities.
 *HIAA—Hobby Industry of America
 *NAR—National Association of Rocketry

COUNTDOWN CHECKLIST

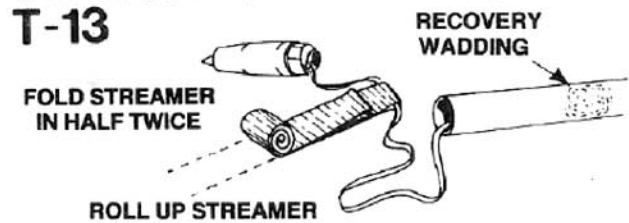

Loosely pack 8-10 squares of flame resistant recovery wadding into the body tube from the shock cord end. Fold the streamer in half lengthwise. Fold again, then roll streamer tightly until the streamer fits loosely into the rocket body.

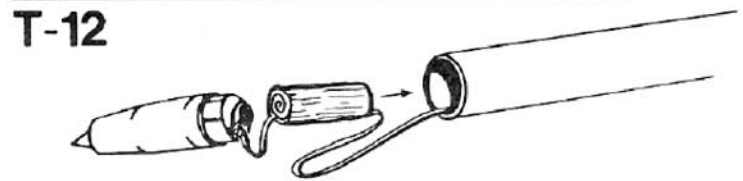

Pack the shock cord and streamer into the rocket body. Slide nose cone into place.

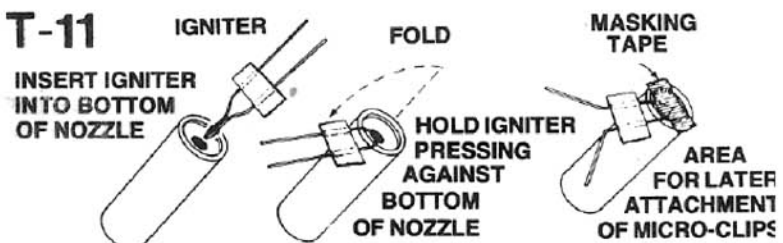

Select an engine and install an igniter as directed in the engine instructions. The engine recommended for use with this rocket is the D12-3 made by Estes.

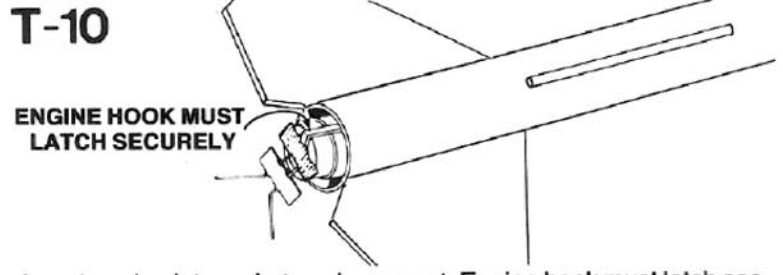

Insert engine into rocket engine mount. Engine hook must latch securely over end of the engine.

T-9 Disarm the launch panel—REMOVE SAFETY KEY!

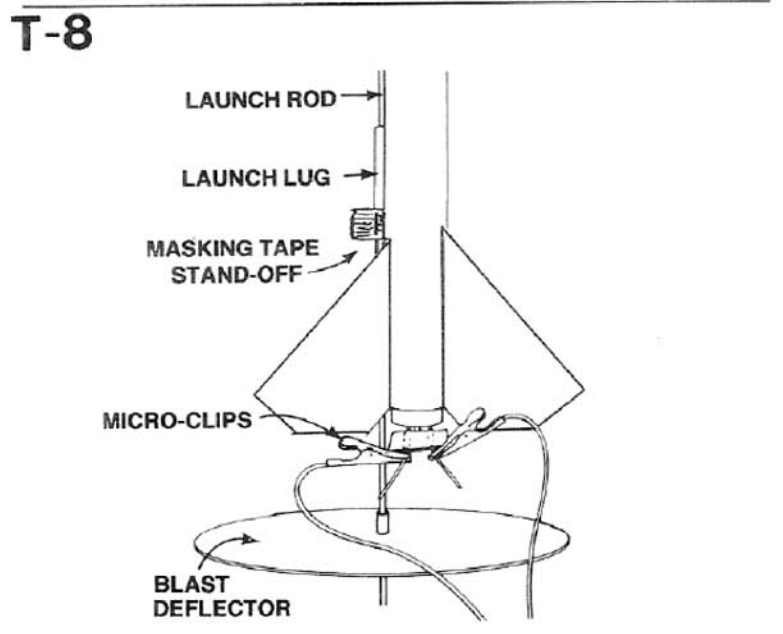

Slide launch rod through rocket launch lug and place rocket on launch pad. Make sure the rocket slides freely on the launch rod. Clean the micro-clips and attach them to the igniter wires. Arrange the clips so they do not touch each other or the metal blast deflector. Attach clips as close to protective tape on igniter as possible.

T-7 Clear the launch area. Alert recovery crew and trackers. Check for low flying aircraft and unauthorized persons in the recovery area.

T-6 Arm the launch panel—INSERT SAFETY KEY!

5-4-3-2-1-LAUNCH!!

Repeat Countdown Checklist for each flight.

MISFIRE PROCEDURE

Disarm the launch panel. Wait one minute before approaching the rocket on the launch pad. Remove the rocket, clean the igniter residue from the nozzle of the engine, and carefully install a new igniter. Repeat the Countdown Checklist.

Failure of the rocket engine to function properly is nearly always caused by a failure to install the igniter correctly. This failure permits the igniter to heat and burn into two pieces without igniting the engine.

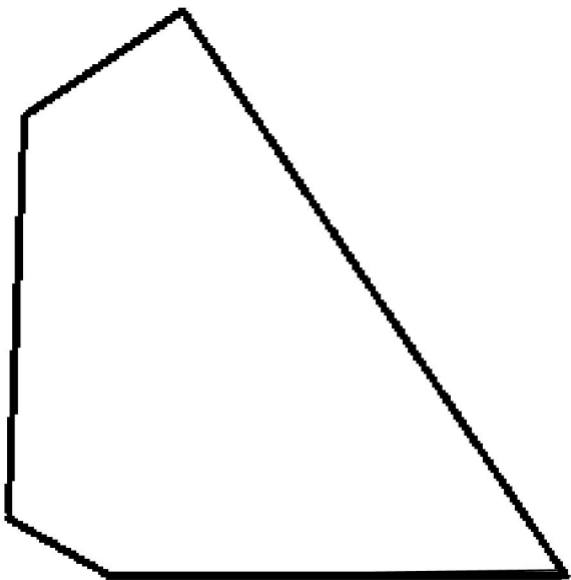

WASP

1

1

2

2

WASP

3

3



CRADLE HERE



CRADLE HERE



CRADLE
HERE



CRADLE
HERE



ESTES IND. 37245



Body tube: BT-55 12"

Foil Wrap length and width (3 1/4 " x 4 1/4")