





ESTES INDUSTRIES
1295 H STREET
PENROSE, CO 81240 USA

Estes
Challenge
series

Tomcat™
FLYING MODEL ROCKET KIT #2086

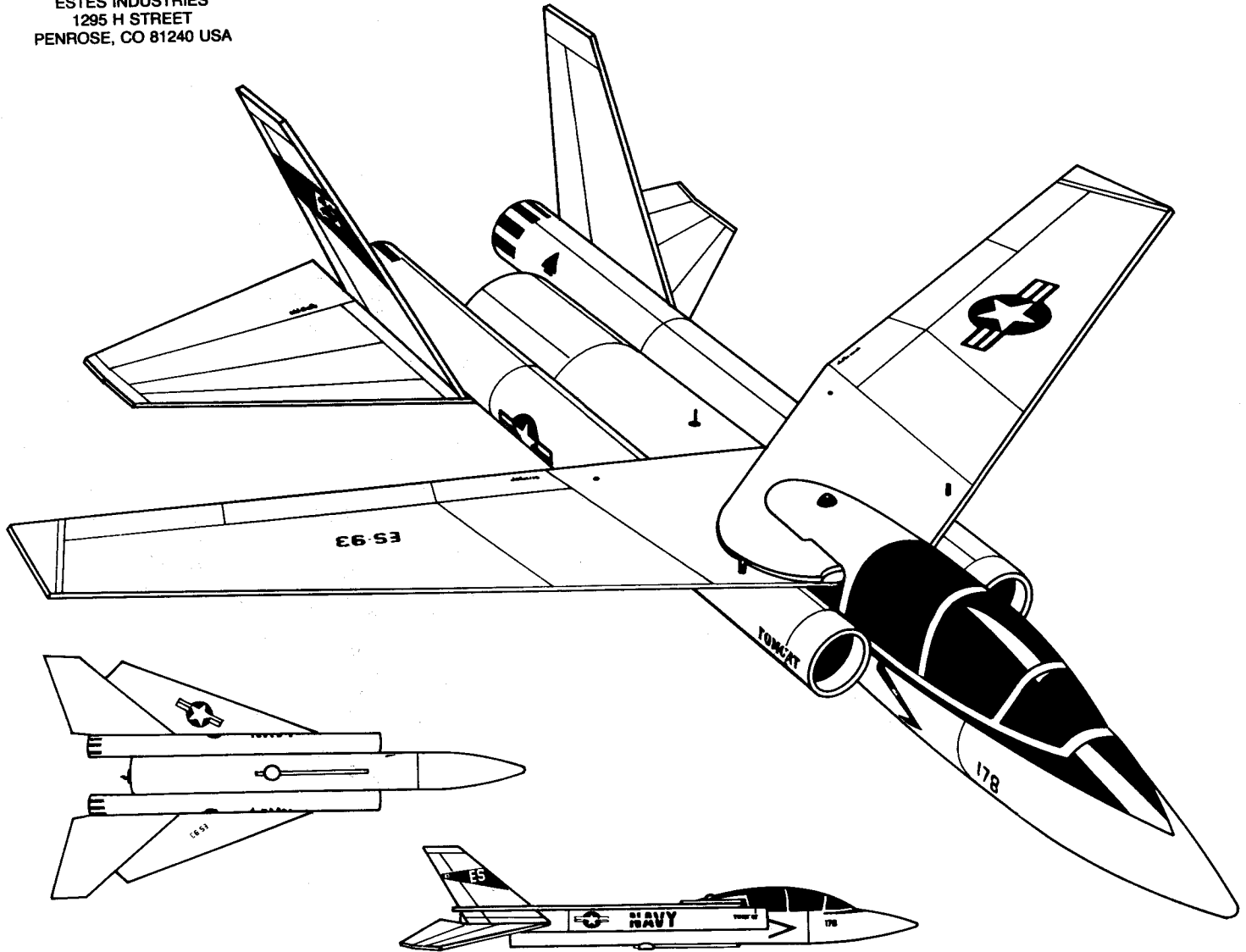

HOW TO USE THESE INSTRUCTIONS:

READ ALL INSTRUCTIONS BEFORE STARTING WORK ON THIS MODEL

- A. The Tomcat™ is designed to challenge the skills of the advanced model rocket enthusiast. Follow the instructions carefully and in the proper order.
- B. Read each step first and visualize the procedure thoroughly in your mind before starting construction.
- C. Lay parts out on the table in front of you. (Check inside tubes for any small parts.)
- D. Use exploded view to match all parts contained in kit.
- E. Collect all construction supplies that are not included in the kit.
- F. A marking guide for use on the engine mount construction can be found on page 2 of this instruction booklet.
- G. Test fit parts before applying any glue.
- H. Sand parts as necessary for proper fit.
- I. The construction supplies required for each step are listed at the beginning of each step.
- J. Check off each step as you complete it.

CONSTRUCTION SUPPLIES

In addition to the parts included in your kit, you will need these construction supplies. Each step shows which supplies will be required.



SCISSORS



PENCIL



RULER



HOBBY KNIFE



GLUE
(white or yellow)



PLASTIC CEMENT



SANDING SEALER



SANDPAPER



MASKING TAPE



SPRAY PAINT



EPOXY GLUE

GLUE IS APPLIED TO SURFACES SHOWN IN RED.

EXPLODED VIEW

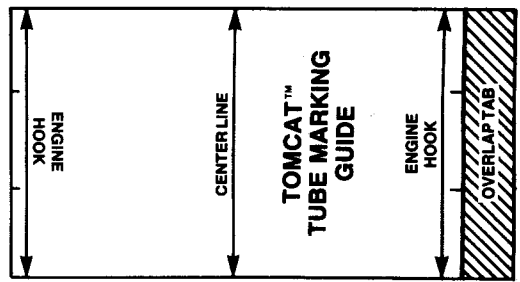
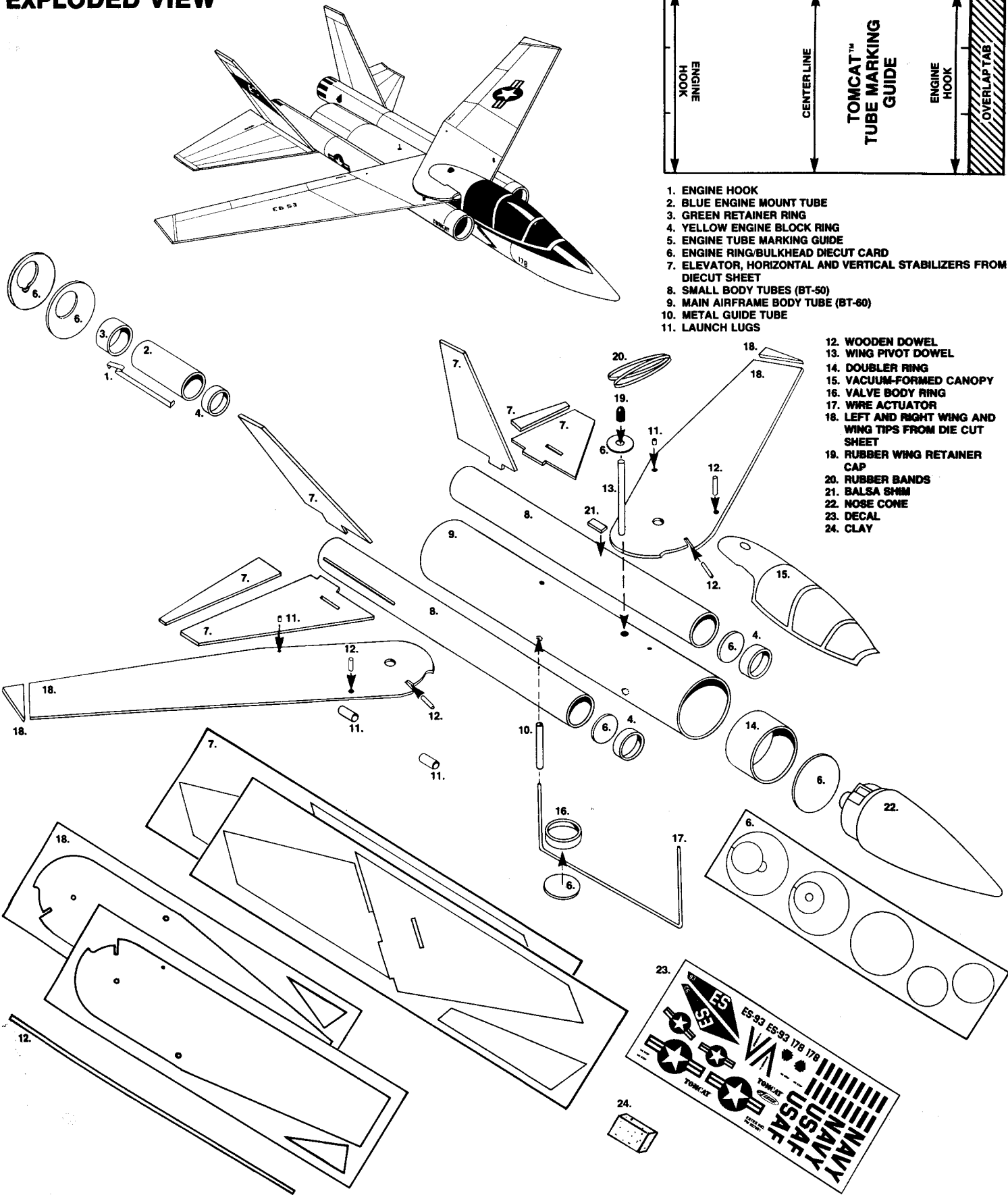

1. ENGINE HOOK
2. BLUE ENGINE MOUNT TUBE
3. GREEN RETAINER RING
4. YELLOW ENGINE BLOCK RING
5. ENGINE TUBE MARKING GUIDE
6. ENGINE RING/BULKHEAD DIE CUT CARD
7. ELEVATOR, HORIZONTAL AND VERTICAL STABILIZERS FROM DIE CUT SHEET
8. SMALL BODY TUBES (BT-50)
9. MAIN AIRFRAME BODY TUBE (BT-60)
10. METAL GUIDE TUBE
11. LAUNCH LUGS
12. WOODEN DOWEL
13. WING PIVOT DOWEL
14. DOUBLER RING
15. VACUUM-FORMED CANOPY
16. VALVE BODY RING
17. WIRE ACTUATOR
18. LEFT AND RIGHT WING AND WING TIPS FROM DIE CUT SHEET
19. RUBBER WING RETAINER CAP
20. RUBBER BANDS
21. Balsa SHM
22. NOSE CONE
23. DECAL
24. CLAY

EXTREMELY IMPORTANT: THE EXPLODED VIEW IS FOR REFERENCE ONLY! DO NOT USE THIS DRAWING ALONE TO ASSEMBLE THIS MODEL.

The exploded view is only intended to assist you in locating the parts included in this kit. Refer back to this exploded view as you build your model step by step. This method will help you to put the parts into perspective as you progress through the construction.

1. ENGINE MOUNT (INITIAL ASSEMBLY)



- A. Locate the metal engine hook, light blue engine mount tube, green retainer ring, yellow engine block ring and engine tube marking guide.
- B. Locate and cut out the engine tube marking guide on page 2 of the instruction book.
- C. Wrap guide around tube and mark locations as shown. Remove marking guide and save in your Tomcat™ file.
- D. Place engine tube in a door frame and draw connecting lines the length of the tube. You now have three lines: a double line for the engine hook placement and another line on the opposite side for alignment of the engine tube during the centering ring installation step.
- E. Measure in from one end of engine tube and place three marks as shown: at 10 mm (3/8"), 38 mm (1 1/2"), and 64 mm (2 1/2").
- F. Make a slit for the engine hook at the 64 mm (2 1/2") mark. Place engine hook into slit. Make sure engine hook is aligned between the engine hook lines. Apply glue around tube 38 mm (1 1/2") from front end. Slide retainer ring into place. Smooth glue joint as shown.
- G. Apply glue to inside front end of engine tube. Insert engine block in place until it touches engine hook tab. Allow assembly to dry.

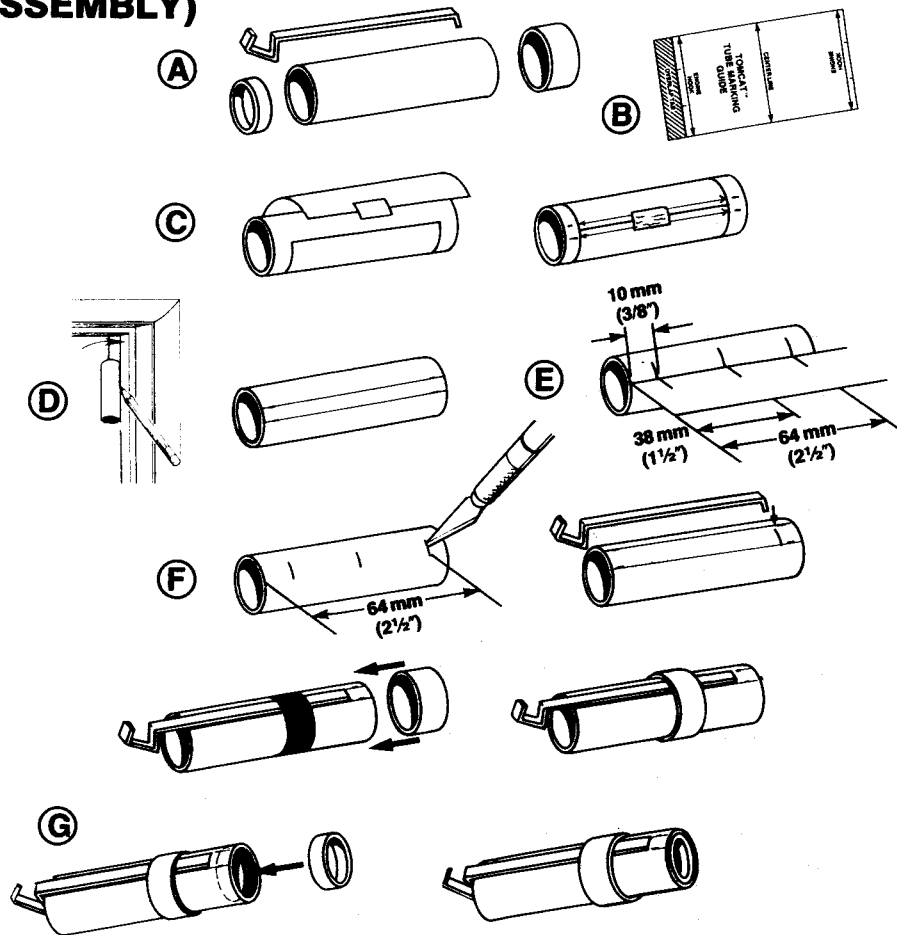

2. ENGINE MOUNT (FINAL ASSEMBLY)



- A. Locate engine ring/bulkhead diecut card set. Remove the two engine rings from card. Remove the small disks from the engine rings but retain them for steps 14 and 18.
- B. Locate engine mount tube. Apply glue to outside of engine tube at the 10 mm (3/8") mark and slip notched engine ring onto rear end of engine tube. Align tick mark on ring to line drawn on top of engine tube.
- C. After correctly positioning ring on tube, make sure ring is at a right angle to tube. Allow to dry.
- D. Apply glue to front of engine mount tube. Position front engine ring onto glue, even with engine hook.
- E. Align the tick mark on the ring with the line on the tube as you did in part B. Assure correct positioning. Place fillets to reinforce rings as shown.
NOTE: Engine rings must align perfectly with tube line to avoid any misalignment of engine thrust. If thrust is not centered correctly, the vehicle may not fly properly.
- F. You may check alignment of both rings and tube by placing assembly in a door frame as shown. Sight for parallel construction. Allow assembly to dry thoroughly.

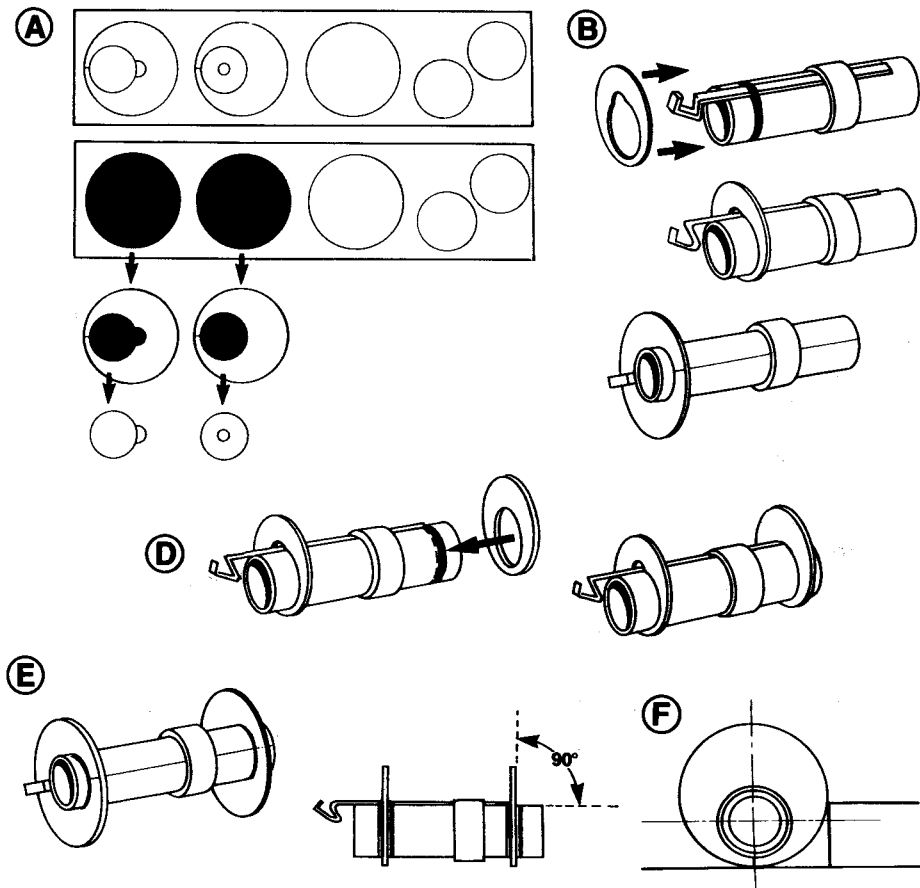

3. ELEVATOR ASSEMBLY

NOTE: This step requires you to build a left and a right tail surface. Double check the position of each piece before gluing.



- A. Locate the diecut balsa sheets with elevator, horizontal and vertical stabilizers.
- B. Remove the complete set of surfaces from the sheets. Lightly sand edges. Set vertical stabilizers aside for now.
- C. Lay horizontal stabilizers and elevators out on a **FLAT** surface. The horizontal stabilizer has a narrow slot cut out near the base.
- D. Match each horizontal stabilizer with an elevator so that the tips are flush.
- E. Use a scrap wood shim cut from the diecut sheet to support the elevator as shown.
NOTE: Use a sanding block to bevel the front edge of the elevator to provide a stronger glue joint.
- F. Apply glue to the edges as shown. Join the elevator to the stabilizer. Make sure tips are flush. Place the scrap wood shim as shown. Allow to dry. Repeat the glue process for the other stabilizer and elevator, making sure that you build a left and right side.

NOTE: Place shim **exactly** as shown for proper deflection angle.

TECH NOTE: The elevator is positioned up to allow the Tomcat™ to transition properly into a glide.

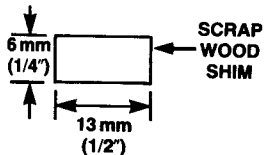
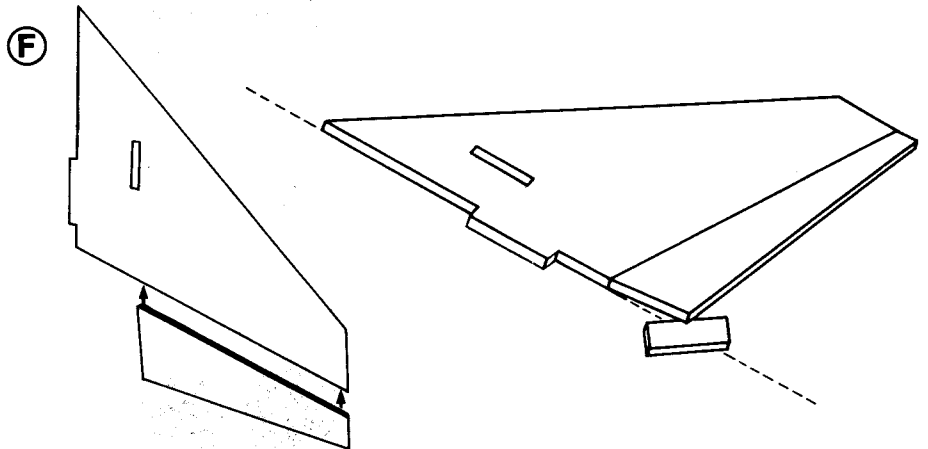
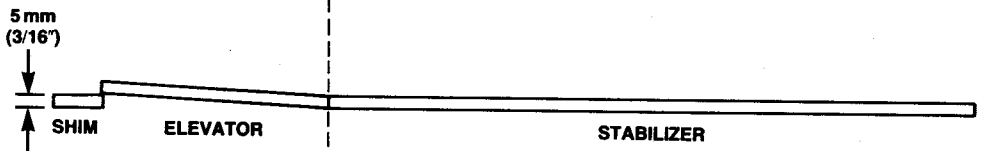
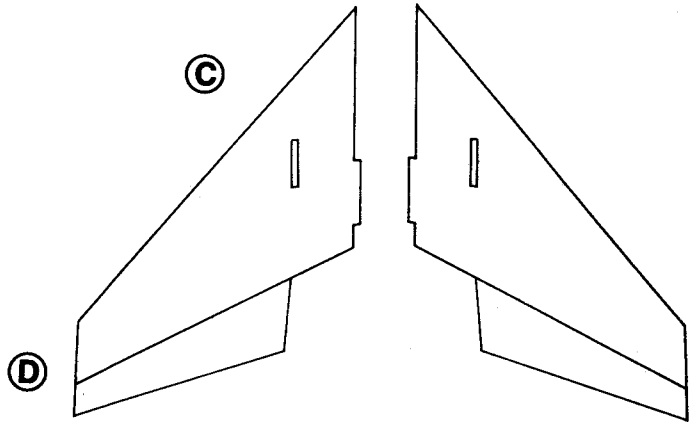
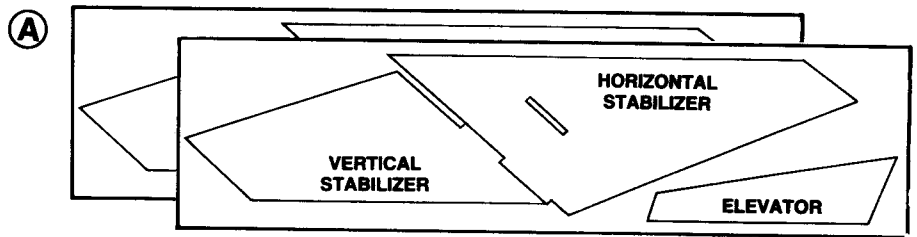

4. AIRFRAME ASSEMBLY (SIDE TUBES)



- A. Locate the two small diameter (BT-50) body tubes. Each tube is 32 cm (12.7") long and has two pre-punched slots at one end.
- B. Locate the two yellow rings.
- C. Locate the engine ring diecut card and remove the two small disks.
- D. Apply glue to one edge of ring and attach a disk. Make sure disk is flush with the ring edges. Repeat this step for the other ring and disk. Allow to dry.
- E. Apply glue as shown. Insert ring (disk side front) into the front end of the BT-50 tube. Make sure ring edge is even with the tube end.

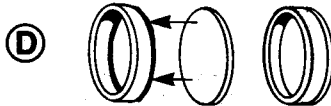
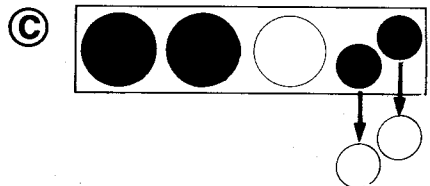
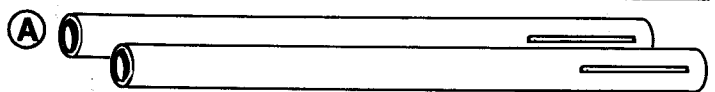

5. HORIZONTAL STABILIZER ASSEMBLY



- A. Locate a stabilizer assembly and insert it into the long slot as shown.
- B. Position small tab of stabilizer into small slot on opposite side of tube.
- C. Use a cotton swab and apply glue fillets between the stabilizer and inside of body tube as shown. Allow assembly to dry.
- D. Repeat for other stabilizer and tube assembly.
- E. When both assemblies are dry, sand excess balsa tab flush with body tube. Do not glue the vertical stabilizers in place at this time.

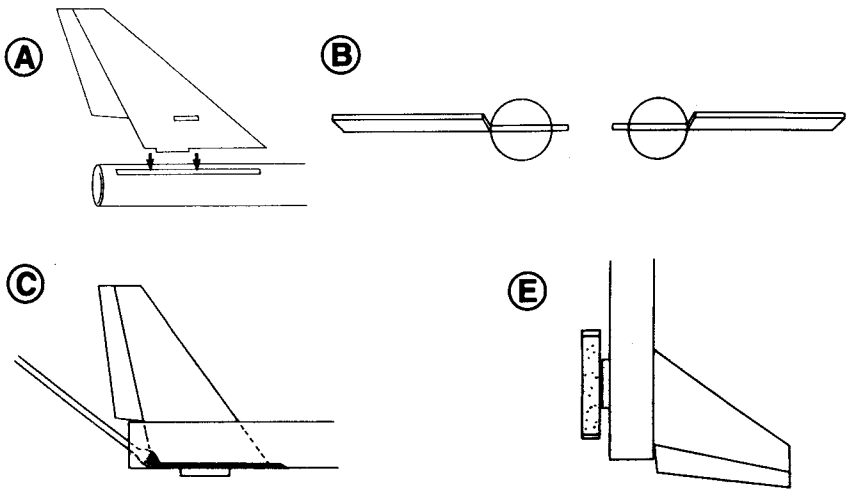

6. MAIN AIRFRAME

IMPORTANT NOTE: Read this step thoroughly before actually gluing any parts.



- A. Locate the main airframe body tube (BT-60). This tube has seven pre-punched holes. Match the tube to the drawing and mark the front end.
- B. Locate the metal guide tube.
- C. Using a piece of sandpaper, roughen the outside ends of the tube.
- D. Insert metal tube into the small hole nearest the large valve hole. Be careful not to distort body tube during this step.
- E. Mix a small amount of epoxy (follow the epoxy instructions carefully). Using a cotton swab, apply epoxy through the valve hole to each end of the metal tube. Flow an ample amount of epoxy around tube to make a secure bond. Allow guide tube to dry thoroughly.
- F. After guide tube is dry, use a sanding block or fine file to sand the guide tube ends even with the side of the body tube.

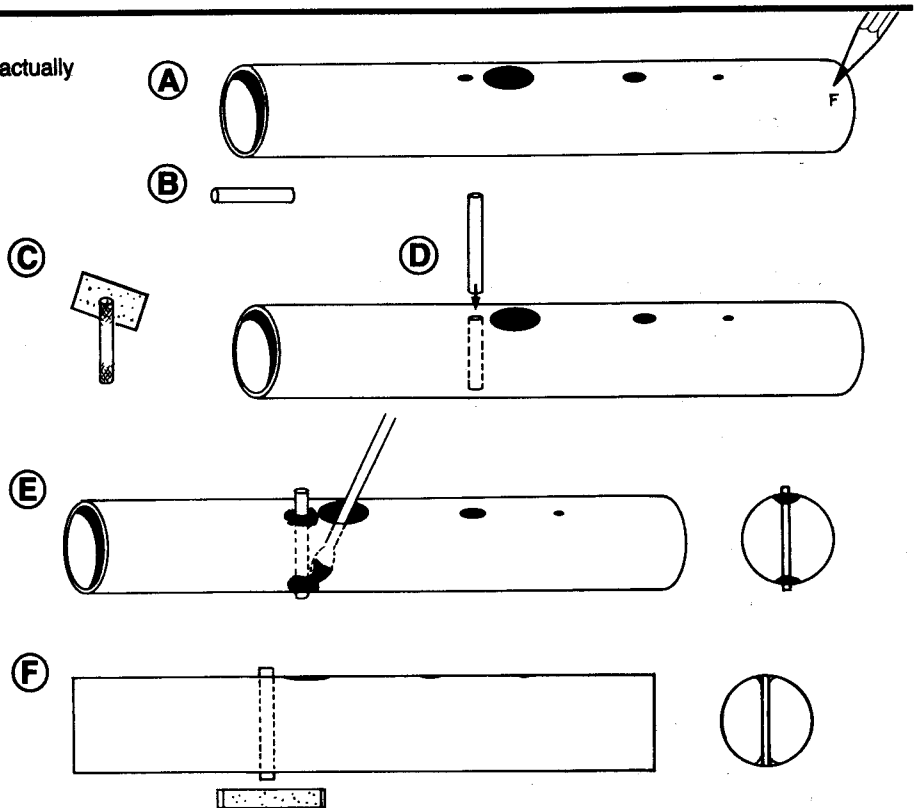

7. MAIN AIRFRAME MARKING



- A. Measure 51 mm (2") from the front end of the body tube.
- B. Wrap a sheet of paper around the front end of tube. Use paper edge as a guide to draw a line around the circumference of the tube. Remove paper guide.
- C. Position body tube so the valve hole (largest hole) is facing down. This is now the top side of the Tomcat™ fuselage.
- D. Use a straight edge to draw a line along the body tube. This line should run through the center of all three holes. This line will be used to properly locate the engine mount assembly. Mark the rear edge for easier sighting reference.

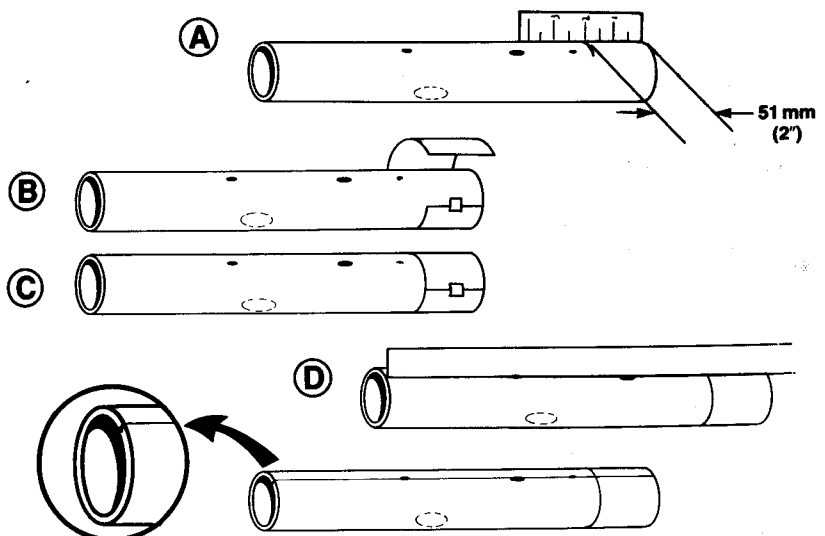

8. ENGINE MOUNT ATTACHMENT



- A. Test fit mount into rear of main tube.
- B. Check alignment as shown. Tick marks on the motor mount ring must line up with the line on the fuselage tube.
- C. Remove mount.
- D. Apply glue as shown.
- E. Insert mount until engine tube is even with body tube.
- F. Apply glue fillets.
- G. Engine mount should be positioned as shown in step B. Allow assembly to dry.

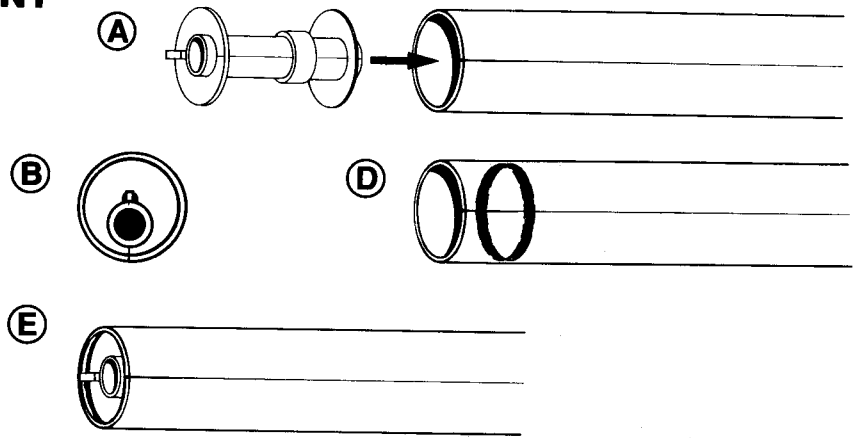

9. AIRFRAME ASSEMBLY (FINAL)

NOTE: This step will require careful alignment of the side tubes and main body tube. Three alignment fixtures are provided to ensure proper alignment and ease of assembly. Be sure to use as flat a building surface as is possible for this step.



- A. Locate the airframe alignment guide diecut sheet shown. Remove the two triangular-shaped stabilizer positioning guides and the airframe alignment guide.
- B. Lay the main body tube on its back (larger valve hole facing up).
- C. Lay the stabilizer/side tube assemblies along both sides.
- D. Position the horizontal stabilizer guides on the tips of the horizontal stabilizers as shown.
- E. Match the front end of the side tubes with the 51 mm (2") line on the main body tube drawn in step 7A.
- F. Insert airframe guide locator tab into the valve hole and position the side tubes into the guide holds as shown.
- G. Draw a line between each tube joint. Ensure all three tubes have a straight line drawn down the side. Refer to drawing.
- H. Remove airframe guide, separate tubes and lightly sand each line to provide a better gluing surface.
- I. Apply small dots of glue along the main body tube lines.
- J. Re-assemble all three tubes and guides. Check proper alignment. Allow to dry.
- K. Apply glue reinforcement fillets along the body tube joints. Allow to dry.

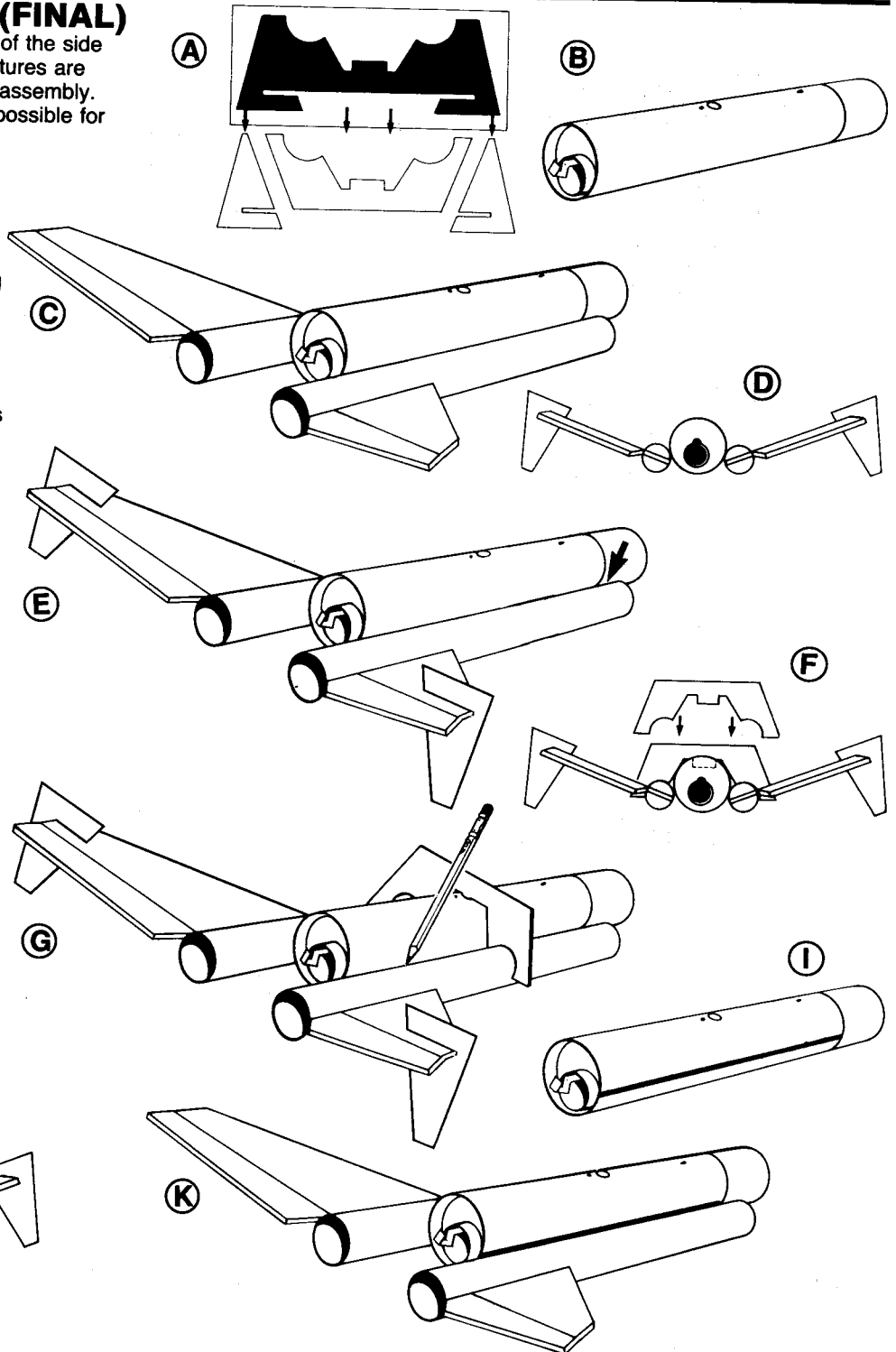

10. LAUNCH LUG PLACEMENT

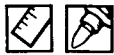

- A. Locate two 5 mm (3/16") launch lugs.
- B. Measure from the rear of main body tube and place a mark at 25 mm (1") and 140 mm (5 1/2").
- C. Apply glue to each of the two launch lugs and place them on the marks as shown. Allow to dry.

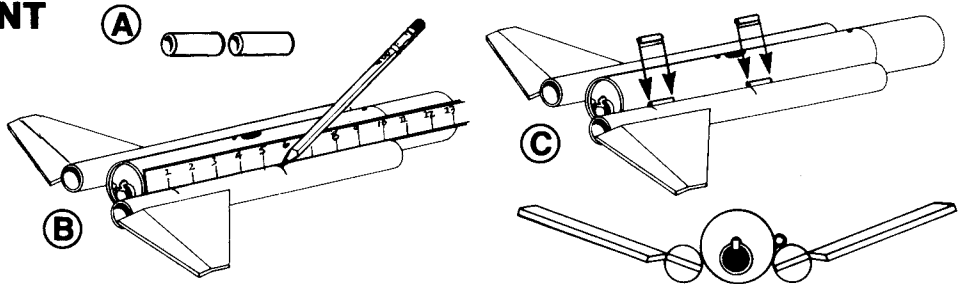

11. WING ASSEMBLY



- A. Locate the two diecut wing sets. Carefully remove the wings and wing tips.
NOTE: Identify the important locations on the wing as shown.
- B. Lightly sand edges and sides smooth.
- C. Lay one wing panel and its tip on your work surface. Note wood grain direction.
NOTE: This step requires a flat work surface. Wax paper under your parts is also a good idea here.
- D. Apply glue to the edge of the wing and join the tip as shown. Allow to dry.
- E. Locate the 2 mm (1/12") by 76 mm (3") long wooden dowel.
- F. Cut two 13 mm (1/2") long pieces from the dowel.
- G. Apply glue to slot in wing as shown. Insert dowel into slot. Make sure dowel is flush to top and bottom of wing surface. Allow to dry.
- H. Locate the remaining 5 mm (3/16") launch lug tube. Cut this tube in half to serve as a reinforcement ring for the trigger pin hole.
- I. Apply glue into the trigger pin hole and insert the reinforcement ring as shown. When glue dries, sand the ring flush to top and bottom surface of the wing.
- J. Locate the remaining portion of the 2 mm (1/12") wooden dowel and cut two 10 mm (3/8") long pieces.
- K. Locate the small puncture mark on the leading edge of the wing. This is the position for the rubber band post. Use your hobby knife to drill a hole at this point that will accept the 2 mm (1/12") x 10 mm (3/8") mm dowel.
- L. Glue the dowel into the wing as shown. The dowel must be flush to the bottom of the wing.

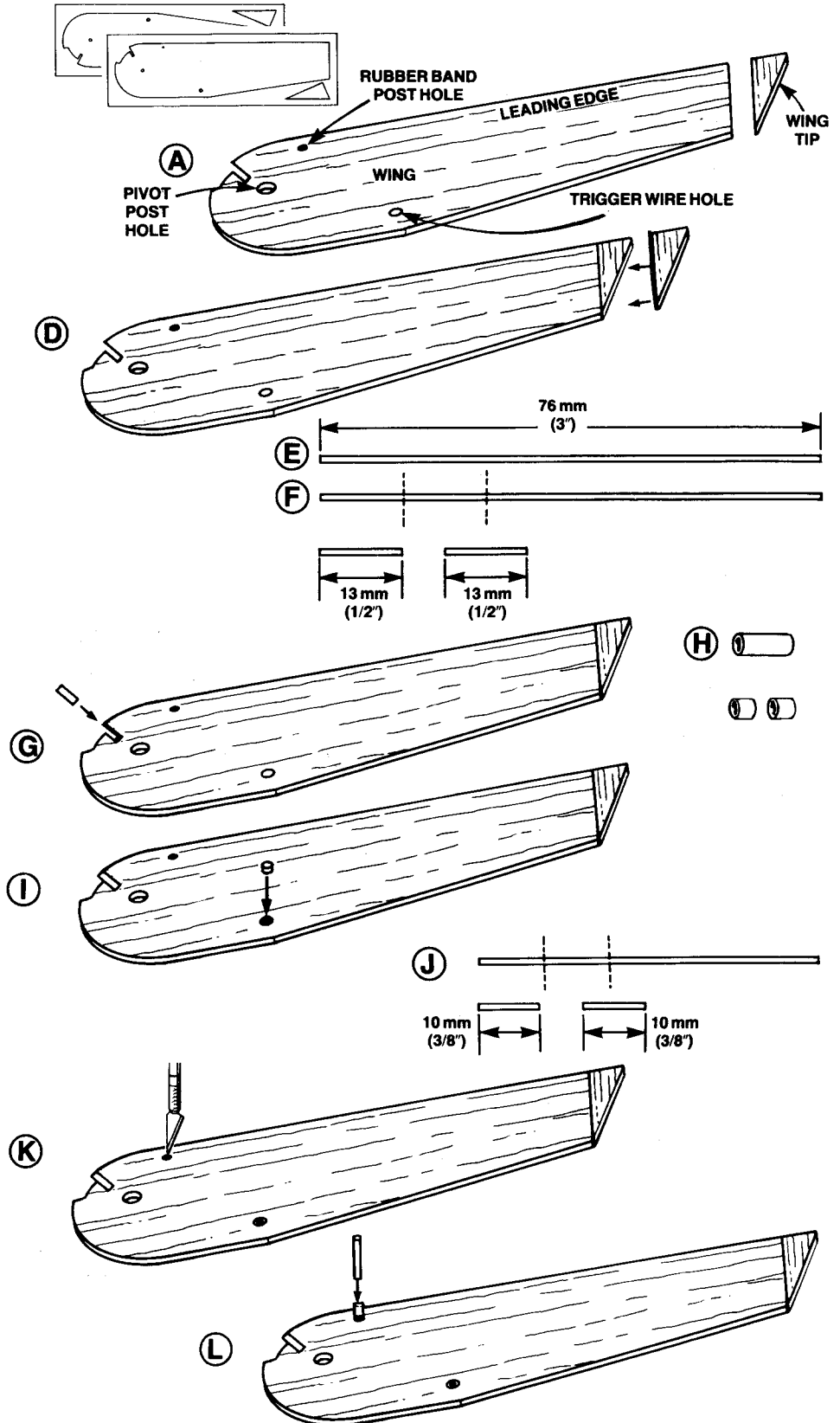

Repeat these steps for the second wing.
IMPORTANT: Be sure to build a left and right wing.

12. WING RELEASE VALVE ASSEMBLY

NOTE: The valve mechanism performs two functions: 1) It holds the wings back in the retracted position at launch; 2) It release and allows the wings to sweep forward for gliding. Attention to detail is important for the successful assembly and operation of this device.



- A. Locate valve body ring, solid diecut white disk (saved from step 2D) and trigger wire.
- B. Lay the wire on the actuator pattern shown on this page. Make sure the wire matches the drawing **exactly**. The wire should lay flat on the work surface with no twists. Adjust if necessary. Set wire aside.
- C. Lay valve body ring on pattern and match the arrowheads on this pattern to the edge of this ring.
- D. Draw lines on the sides of this ring at the arrowhead points.
- E. Wrap fine/medium grit sandpaper on the actuator wire and lay wire across the diameter of the ring - touching the marks.
- F. Sand a notch the size of the wire diameter into the ring, then stop. Set ring aside, remove sandpaper from wire.
- G. Test fit actuator wire in bottom two fuselage holes as shown. Ensure there are no bows or abnormal bends. The long end goes into the forward hole.
- H. Remove wire from body tube.
- I. Apply glue to the notched end of valve body.
- J. Lay wires in notches.
- K. Position diecut disk onto valve body, trapping the wire in place. Allow to dry. NOTE: Make sure disk is evenly and firmly attached to the valve body. Allow to dry.
- L. Free valve assembly by twisting it so that it moves along wire.
- M. Insert wire into airframe body tube and position valve into the large hole as shown.
- N. Use a piece of tape to hold valve on wire at this position and remove wire and valve assembly from the airframe.
- O. Bond the valve to the wire permanently by mixing a small amount of epoxy and applying it inside the valve body over the wire as shown.
- P. Reposition wire and valve in the airframe. Allow epoxy to cure.
- Q. Apply a small amount of epoxy to a scrap wood applicator and bond the wire to the front inside wall of the body tube. Allow epoxy to cure.

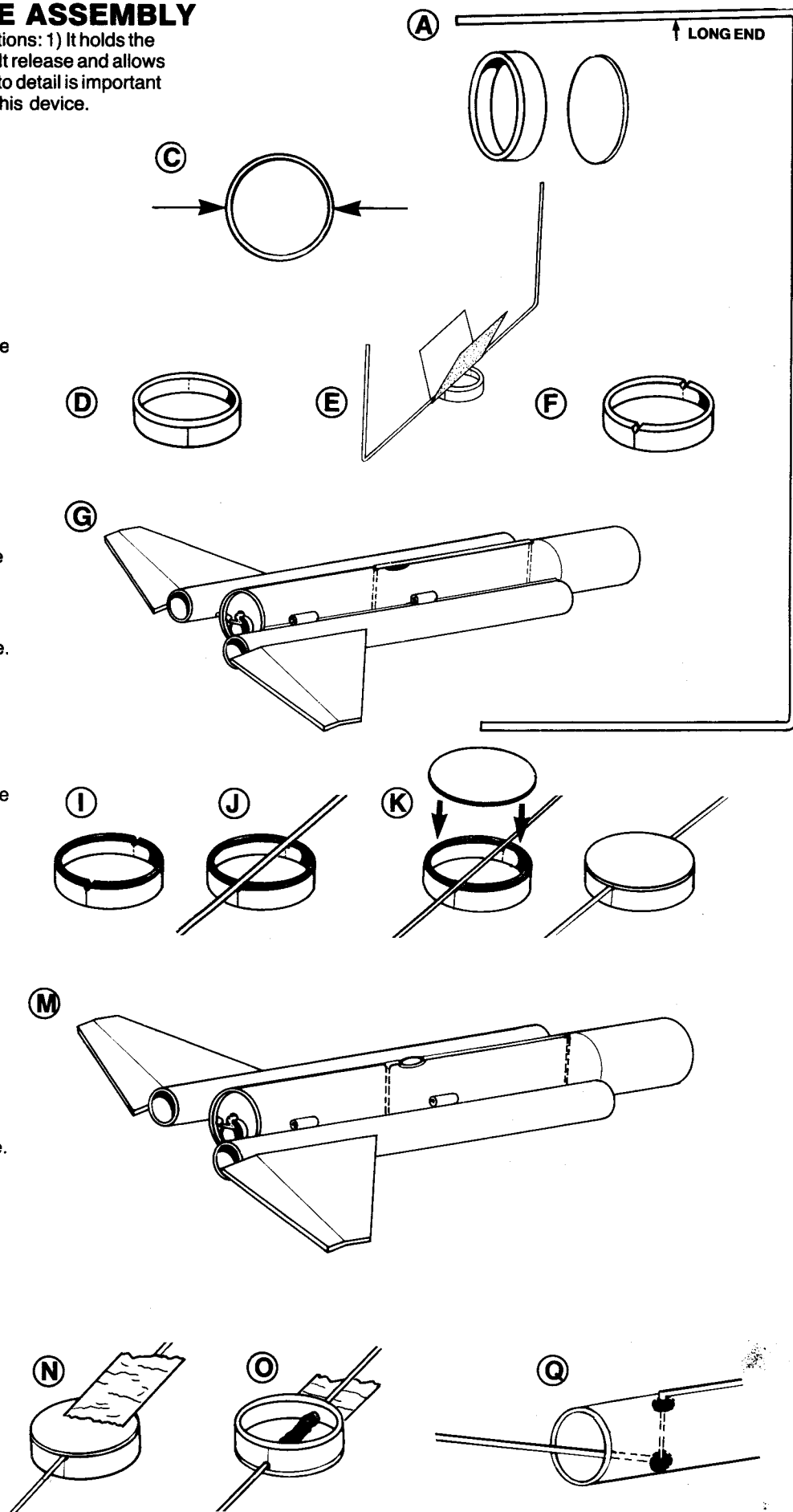

13. WING PIVOT POST AND FORWARD AIRFRAME DOUBLER



- A. Locate the 2 mm (3/16") by 54 mm (2 1/8") wing pivot dowel. Insert the dowel through the remaining holes in the fuselage tube as shown flush to the bottom of the fuselage.
- B. Glue in place as shown. Use scrap balsa stick or cotton tip applicator to apply glue to the joint.
- C. Insert doubler ring - do not apply glue.
- D. Remove the last solid disk from diecut card.
NOTE: Keep empty die cut card to use as an alignment guide on step 22B.
- E. Press disk (technically called a bulk-head) in place.
- F. Apply glue to body and bulkhead joint. Allow to dry.

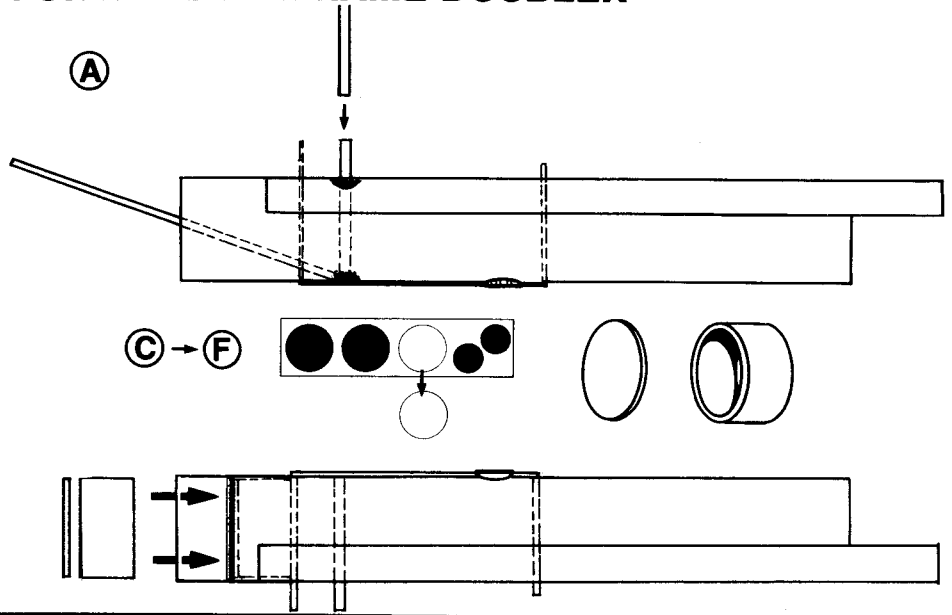

14. CANOPY PREPARATION



- A. Inspect the vacuum-formed canopy. Identify the outline of the canopy. The lines are better defined on the inside of the piece.
- B. Locate the dimple on upper rear of canopy. Use the tip of your knife to "drill" a small hole the size of the dimple (you will need to enlarge this hole later in step 20C).
- C. Make one pass along the edge of the part with your knife. Do this on the inside. Do not cut through. Just make a deep scribe.
- D. Fold the plastic back and forth at this line. The plastic will weaken and break away along your scribe line.
- E. Lightly sand edges smooth. Set aside.

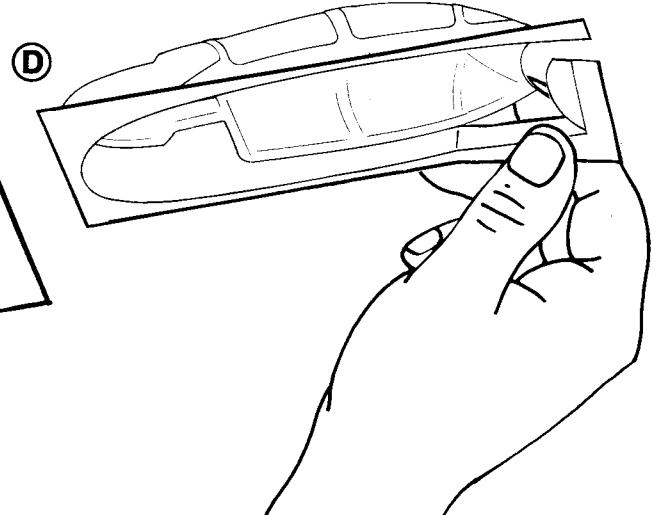
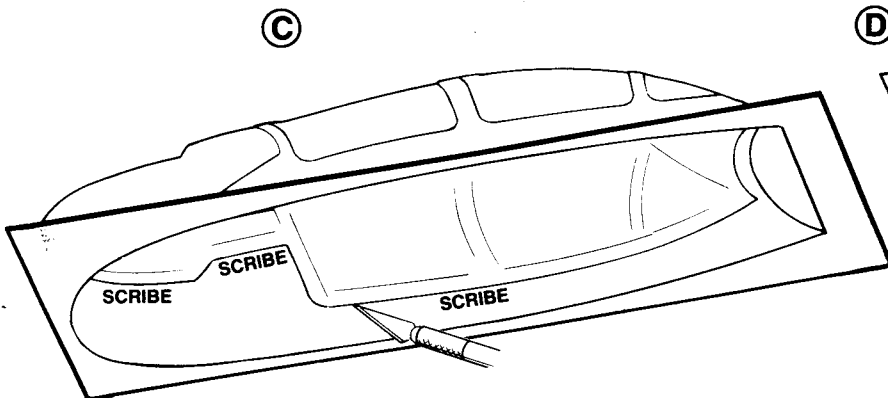
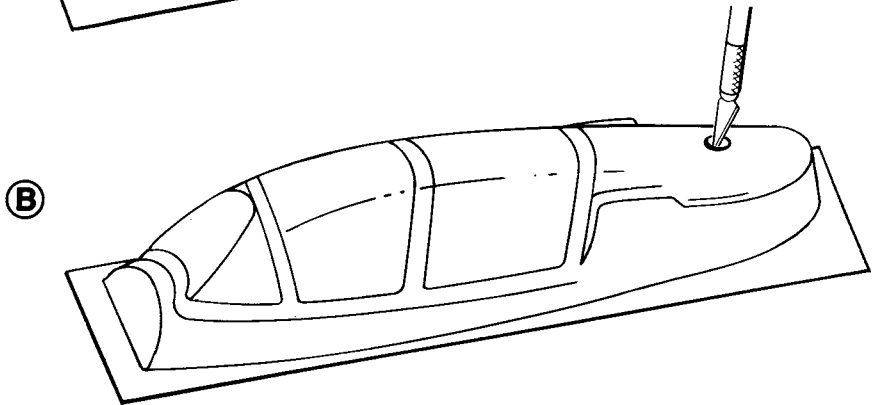
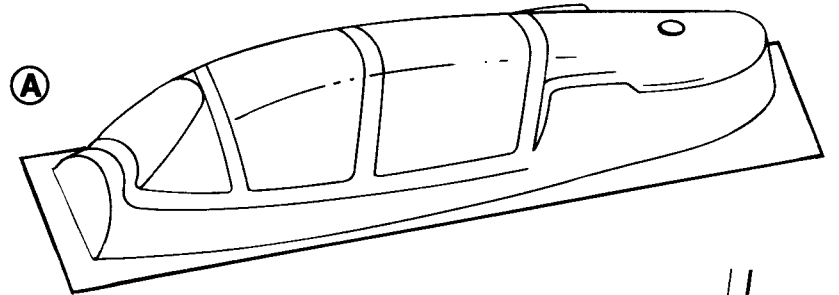

15. WING ATTACHMENT

- A. Locate the following: left and right wing panels; diecut washer from step 2D; rubber wing retainer cap.
- B. Arrange the wing panels in a left and right fashion on the airframe pivot post. Make sure both small rubber band posts are pointing up and are on the forward leading edge of the wing.
- C. Push the diecut washer onto the pivot and snug against the wing, followed by the rubber retainer cap. Do not glue cap at this time.

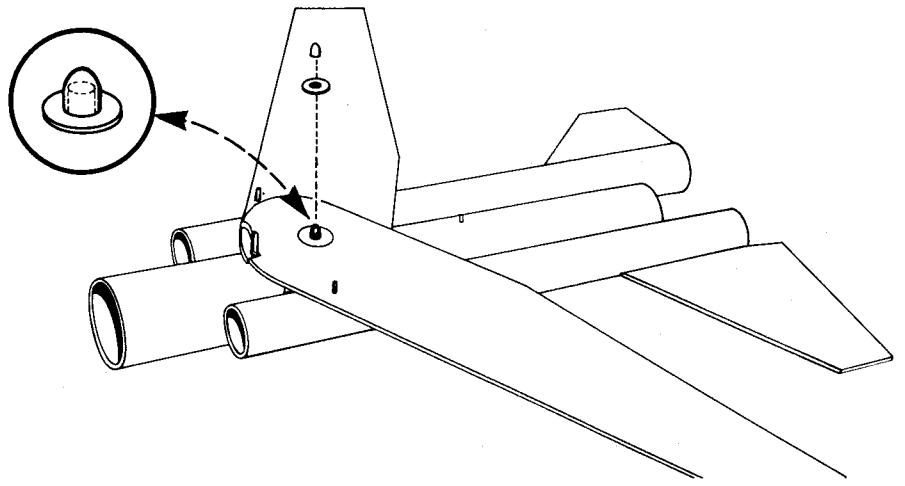

16. SWING WING ACTUATOR ATTACHMENT

NOTE: The rubber bands are tensioned to pull the wing panels forward for gliding flight. Use two rubber bands to provide positive forward sweep action. The center wire stops the wing at the proper sweep angle. Always check rubber band condition before flight.

- A. Hook the two rubber bands onto one small leading edge dowel post.
- B. Stretch the rubber around the wire wing stop and attach the other ends to the other dowel.

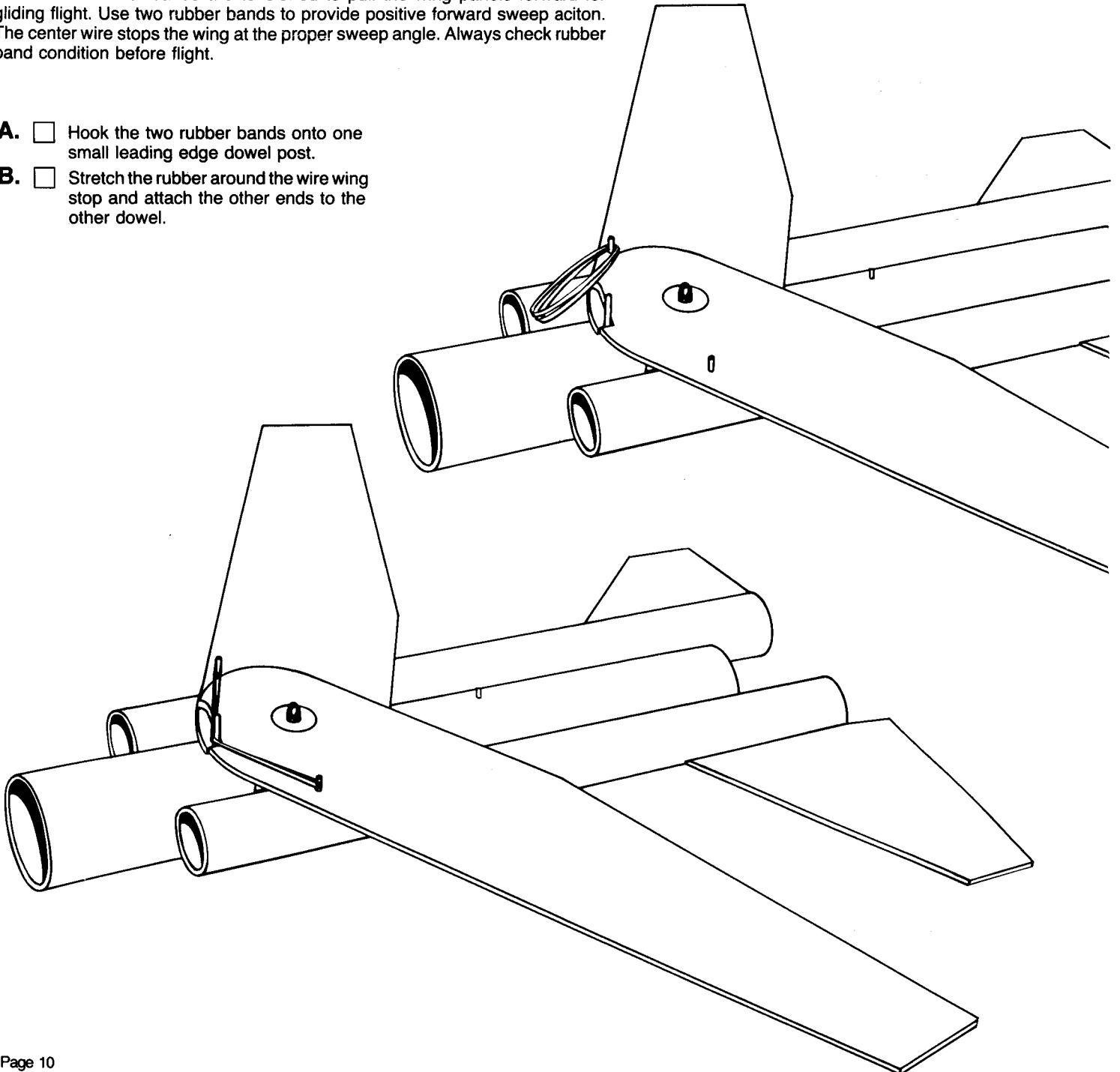

17. WING MECHANISM OPERATION TEST

- A. The wing is now at the forward gliding position.
- B. Gently pull the valve body down away from the airframe until the trigger wire disappears into the body.
- C. Push both wings rearward until the trailing edge trigger wire holes overlap.
- D. Release the valve. The trigger wire should slide into the wing panel holes and trap the wings in the rear sweep position. This is the rocket boost position.
- E. Holding the airframe, release the wings by gently pulling down on the valve body.
- F. Wings will quickly sweep forward into glide mode.

Congratulations! Now you have only a few steps to go.

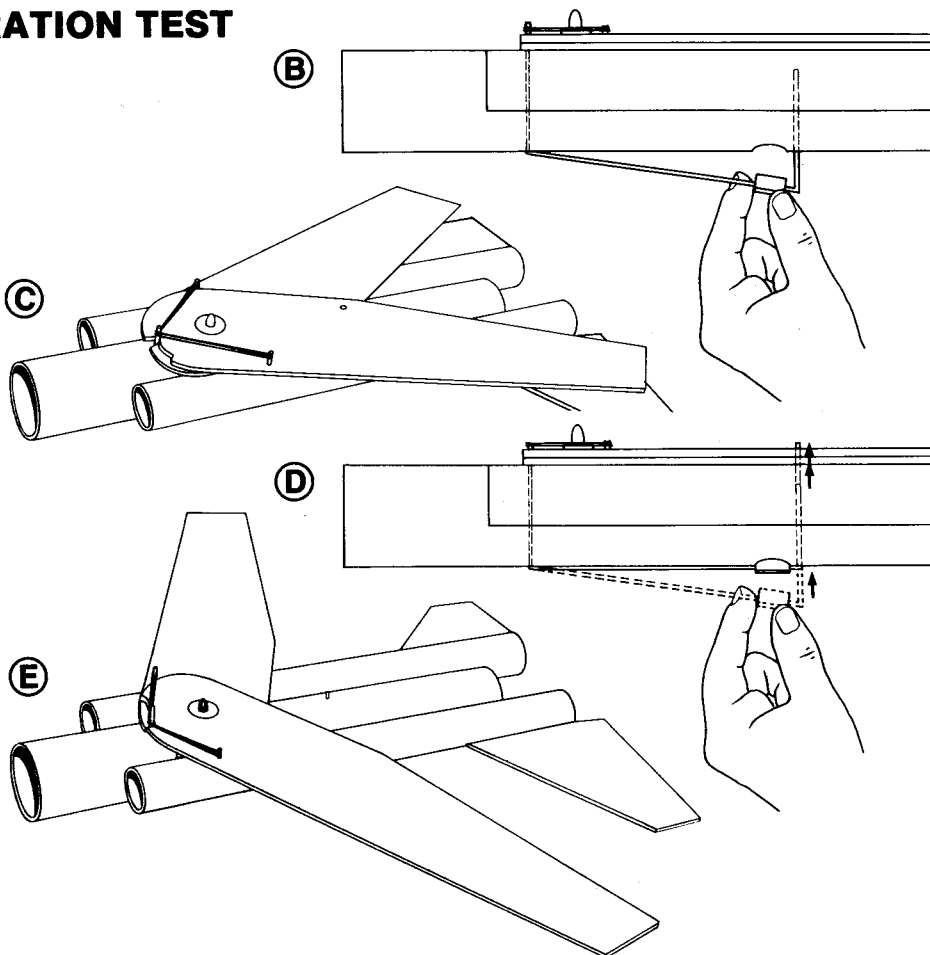

18. WING SHIM ATTACHMENT



- A. Identify the upper wing panel.
- B. With wings in forward position, mark the side tube at the trailing edge of the upper wing panel.
- C. Remove the rubber cap, wing and washer.
- D. Cut a balsa shim 5 mm (3/16") x 19 mm (3/4") long from scrap wood.
- E. Apply glue to the shim and position it ahead of the line you drew in step B. Allow to dry.
- F. Reinstall wing panels **with the upper wing on the shim side** and install the washer.
- G. Place a spot of glue on the dowel pivot and firmly press the retainer cap in place. **DO NOT** glue the retainer cap in place if you intend to paint your model before flight.
- H. Reattach the rubber bands.

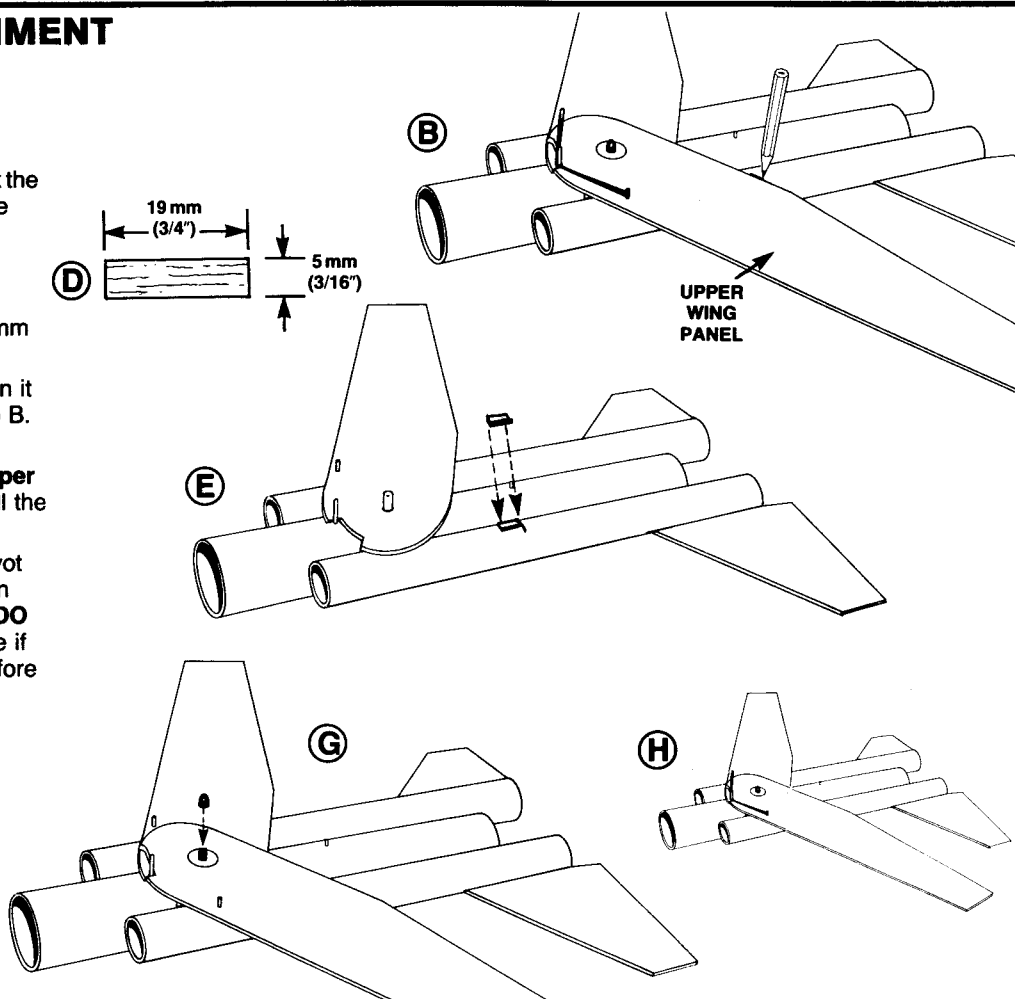

19. VERTICAL FIN ATTACHMENT



- A. Locate the two vertical fins.
- B. Locate the empty diecut card from step 15B. Cut the ends off the card and use corner of the card as 90° guide to align the vertical fin on the horizontal stabilizer. Make two guides, one for each vertical fin.
- C. Test fit vertical fin into horizontal stabilizer slot. Set 90° alignment gauge in place at rear of vertical fin.
- D. Remove fin.
- E. Apply glue to the vertical fin tabs and along the lower edge as shown.
- F. Insert vertical fin into horizontal stabilizer slot.
- G. Hold position of fin until glue sets. Remove alignment guide.
- H. Repeat C-G for the other fin.

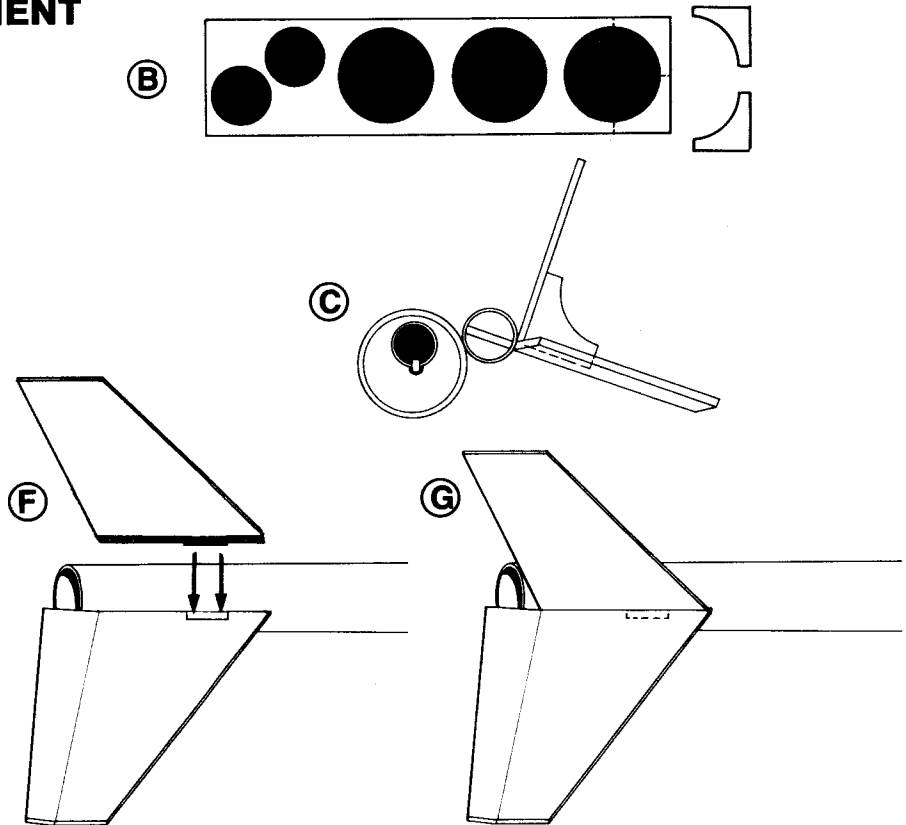

20. NOSE CONE AND CANOPY ATTACHMENT



- A. Insert nose cone with flat portion of shoulder up.
NOTE: Trim excess plastic from seams of plastic nose cone.
- B. Align seam of nose cone with body tube line.
- C. Set canopy on nose cone with rubber retainer cap extending through rear canopy hole. If hole is too small, wrap sandpaper around a pencil point and enlarge the hole as needed (loose fit).
- D. Rear canopy area should rest on the wing surface as shown.
- E. Tape canopy onto nose cone.
- F. Lightly trace around canopy on nose cone portion only. Remove canopy.
NOTE: **DO NOT** glue nose cone to body tube! Nose cone and canopy are intended to be removed from the airframe for maintenance purposes and nose weight adjustment.
- G. Apply cement to the nose cone as shown and match the canopy on the outline.
- H. Reinstall the canopy in position. Adjust the canopy. Be careful - do not glue the nose/canopy accidentally to the body tube. Allow assembly to dry.

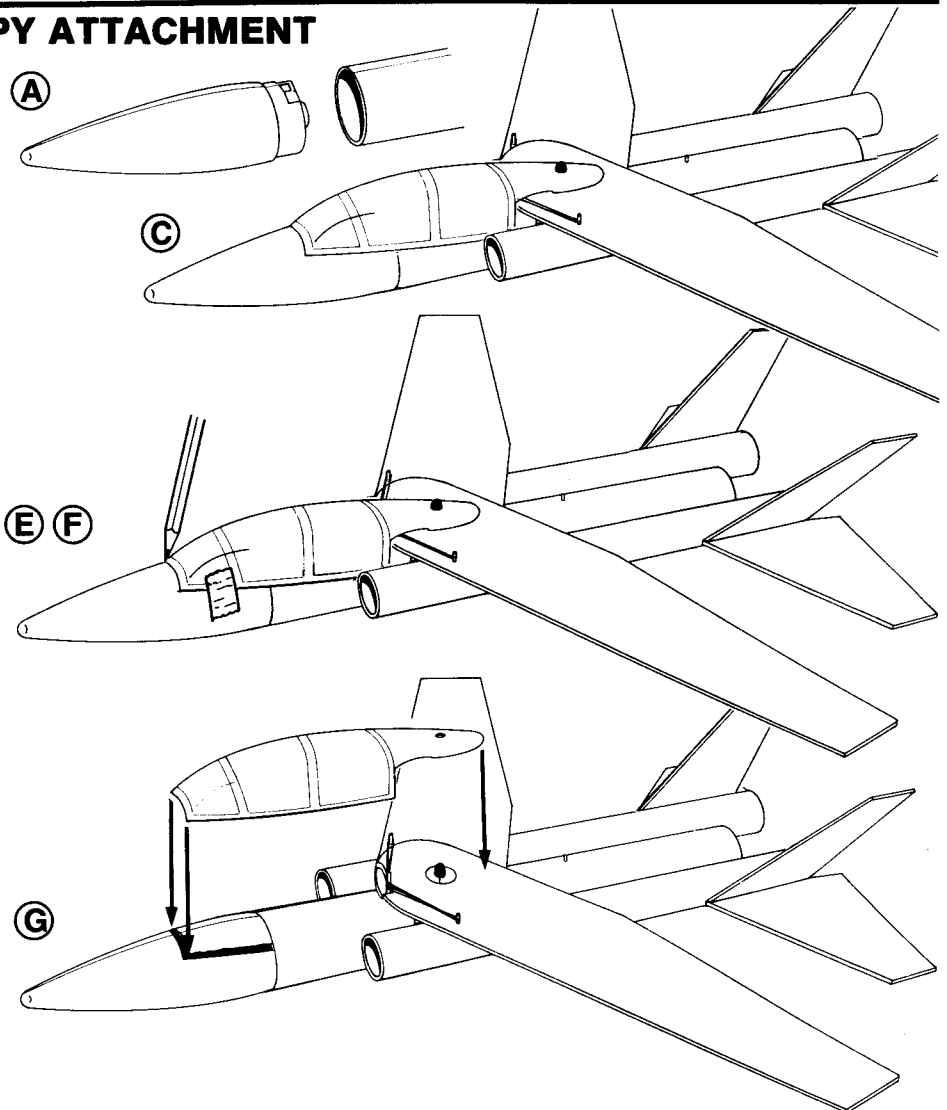

The basic construction of your Tomcat™ is complete.

21. PAINTING YOUR TOMCAT™

NOTE: If you decide to paint the Tomcat™, use spray paint for lighter covering. Be sure to recheck the balance point before flying. The added weight of paint will redistribute the balance and change the flight performance of the glider. You may wish to test fly before you paint. See steps 22 to 25 before painting.



- A. Remove the nose section and wings.
- B. Paint these pieces separately.
- C. Seal the wood surfaces with one or two coats of sanding sealer. Allow each coat to dry. Be sure to sand between coats with fine sandpaper.
- D. Spray a coat of primer and allow to dry.
- E. Give a final coat of color. Allow to dry overnight.
- F. Use the illustrations in this instruction booklet to place decals. A Navy and an Air Force scheme is provided. Cut out the decals one at a time. Allow each decal to soak in water for 30 seconds. Apply to model and lightly blot water away with a paper towel. Allow to dry.

NOTE: Use talcum powder between the wing overlay areas for better sliding action on the painted surfaces.

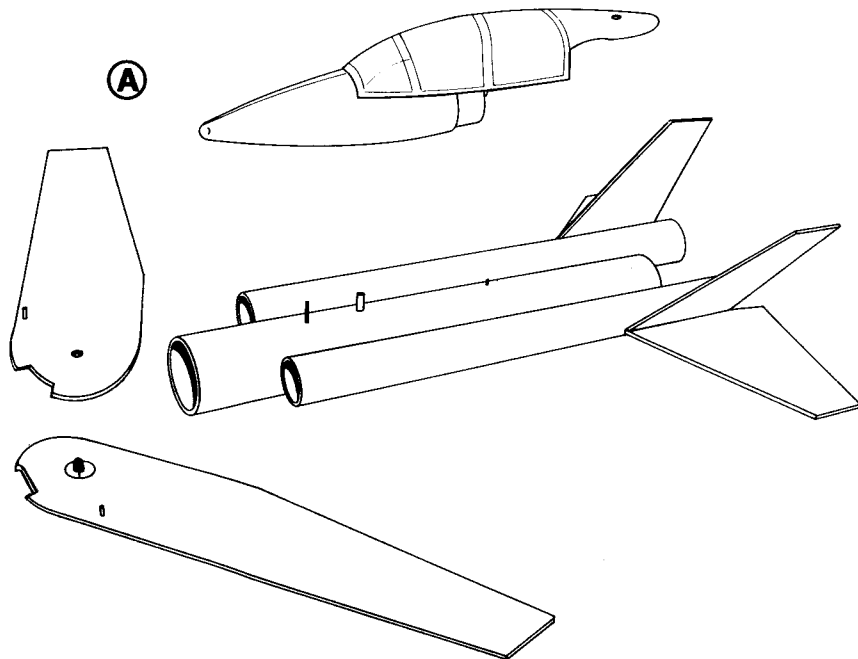

22. BALANCING FOR FLIGHT



- A. Insert a spent engine casing into the engine mount. If you don't have a used engine casing, tape **three** pennies in the rear engine section as shown.
- B. Extend wings to forward (glide) position.
- C. Place piece of tape on wing retainer wire to keep it from pulling out.
- D. Turn the glider on its back.
- E. Position a paper clip on the valve as shown.
- F. Suspend the glider. The glider should balance level with paper clip positioned 3 mm (1/8") ahead of valve body.
- G. If the glider does not balance level, you may need to add weight to the nose or tail depending on which end is heaviest. Clay is a good material to use for this purpose.
- H. Attach the weight to the inside of fuselage behind the nose cone if tail is heavy or under the motor mount if its nose is heavy.

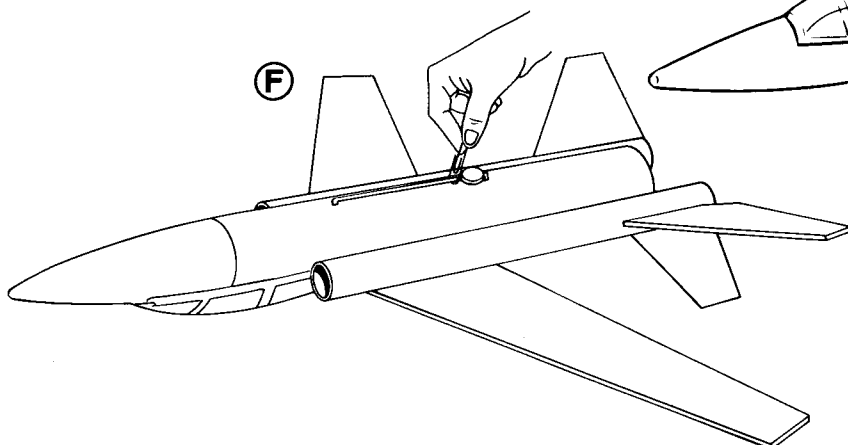
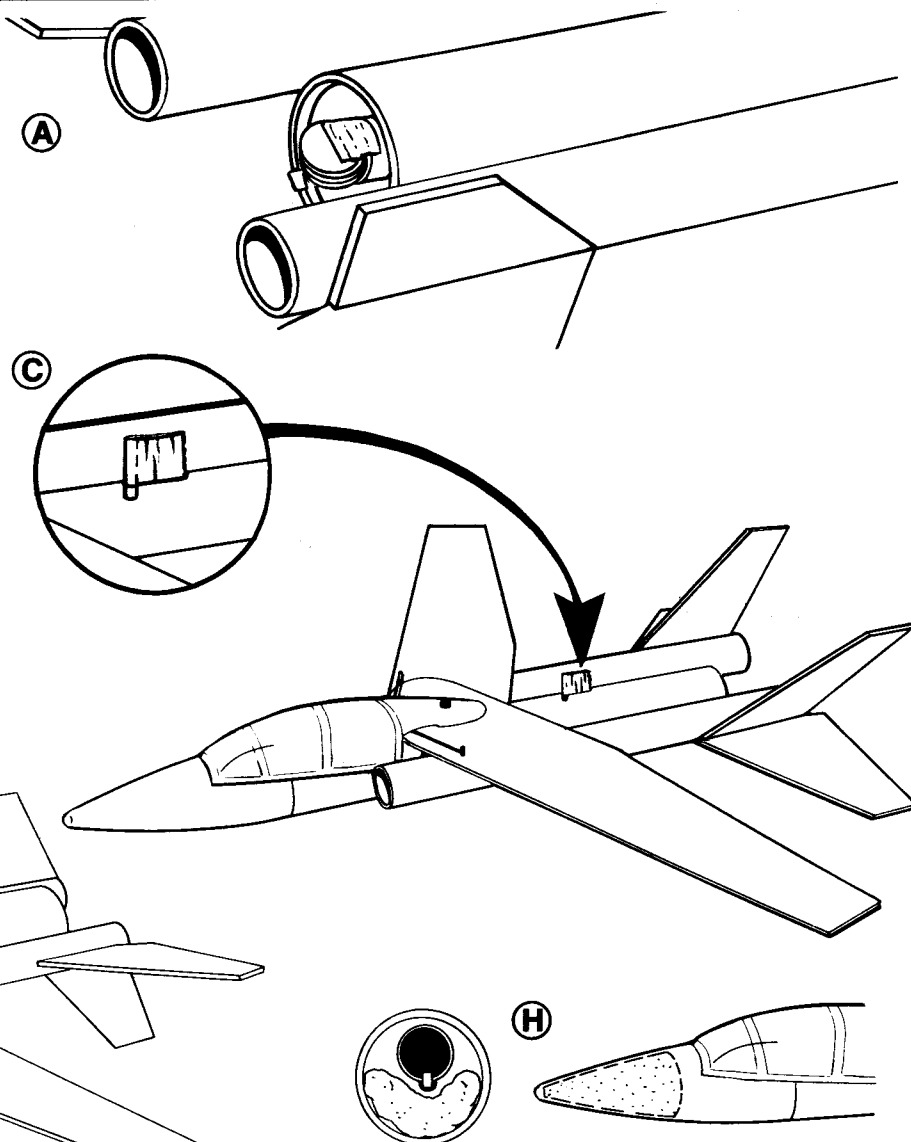

23. LATERAL BALANCING



NOTE: It is important that your finish wings are of equal weight. Remove them from your Tomcat™ and check the weight of each. Sand the surface of the heavy wing until it weighs the same as the

lighter wing. Use a spot of glue in the retainer cap when you install the wings for the final time.

24. TEST GLIDE

NOTE: Your Tomcat™ is now balanced for gliding flight.

- A. Extend wings forward.
- B. Hold glider body at or near the valve (i.e. the balance point)
- C. Hold the glider as shown in a slightly nose down (approximately 1°-3°) altitude and aim the nose at a point on the ground 914 cm (50 feet) in front of you.
- D. Make sure the wings are horizontal.
- E. Give the glider a firm forward **push** (do not throw the model).
- F. The goal is to fly the model in a flat gentle glide straight ahead, pointing in the direction of the fixed point.

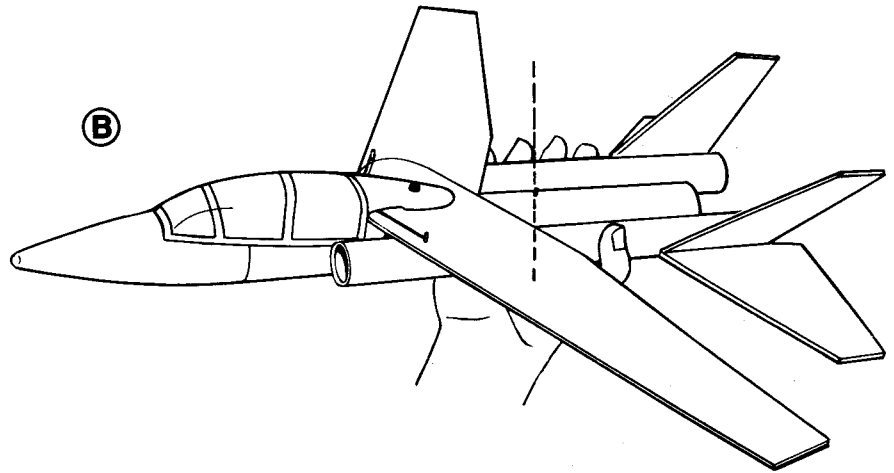

(B)

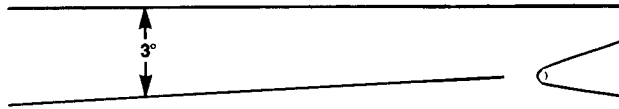

(C)

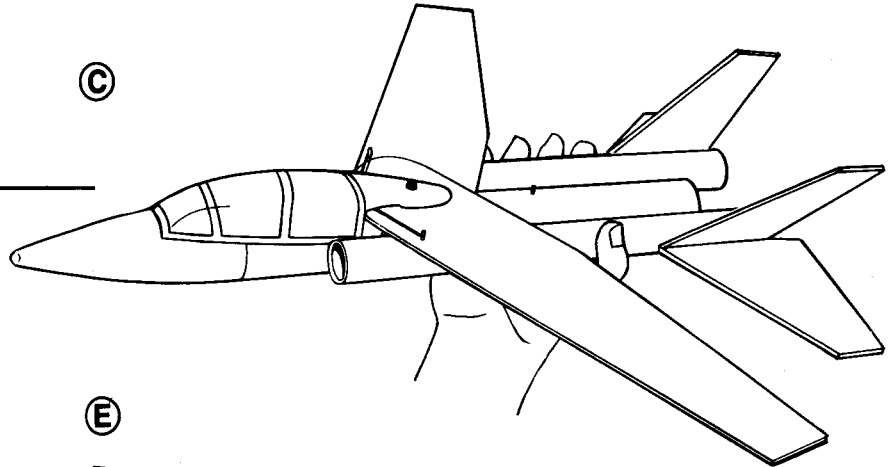

(E)

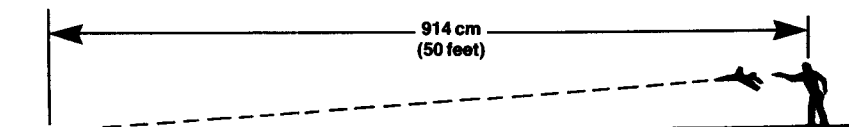
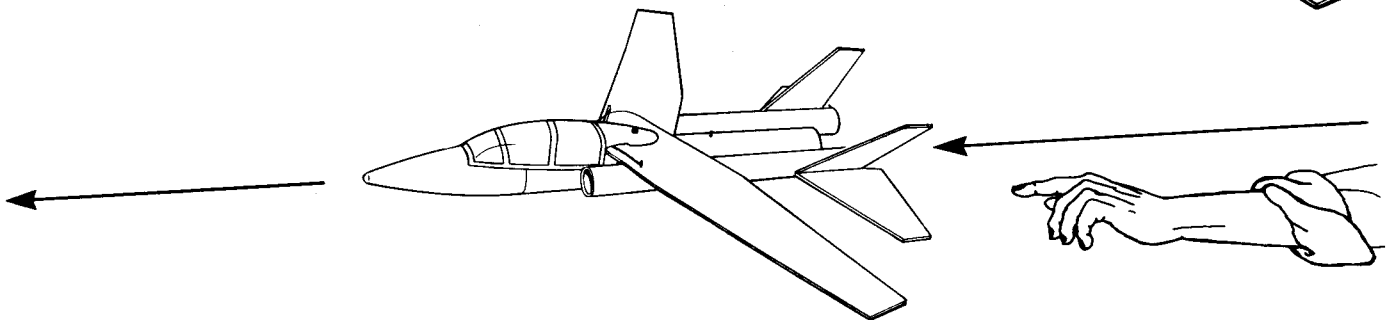

25. ADJUSTMENTS FOR A FLAT GLIDE

- A. If the nose points up and the glider behaves like a roller coaster, add a little weight to the nose compartment. If the nose dives quickly for the ground, remove a little weight from the nose until the flat glide is obtained.
- B. If this glider turns to the left or right abruptly, check the wing for warps or bend or recheck lateral balance. Place wing on flat surface, use steam from a iron to correct warps.

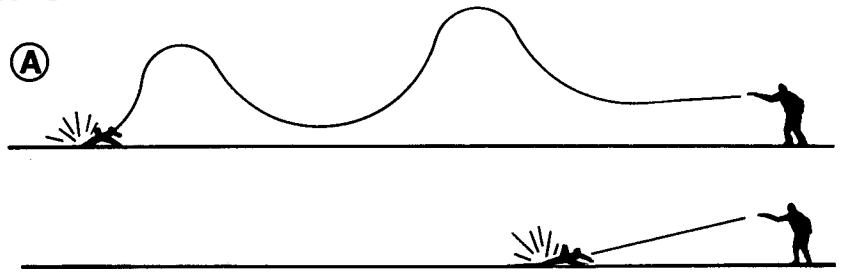

PRELAUNCH PREPARATIONS

- A. After you have trimmed the glider to fly properly. Remove the spent engine casing or the pennies from the rear section.
- B. Retract wings rearward: pull valve body down gently, position wings over trigger pin and release the valve.
- C. Install a fresh engine and follow the standard launching procedures that follow.

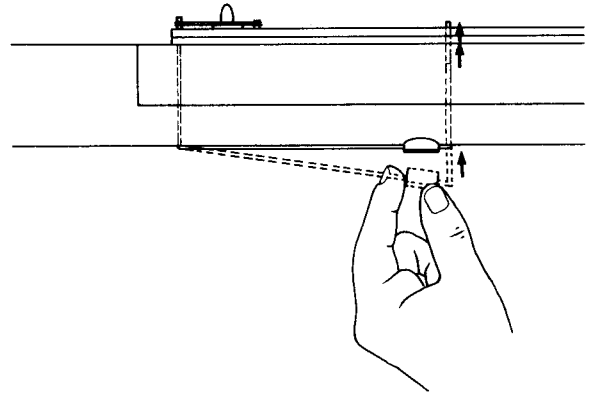
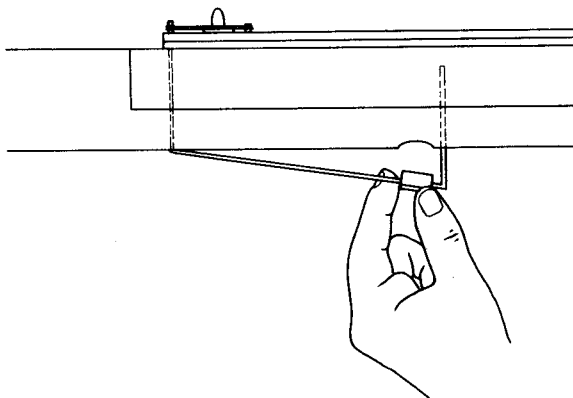
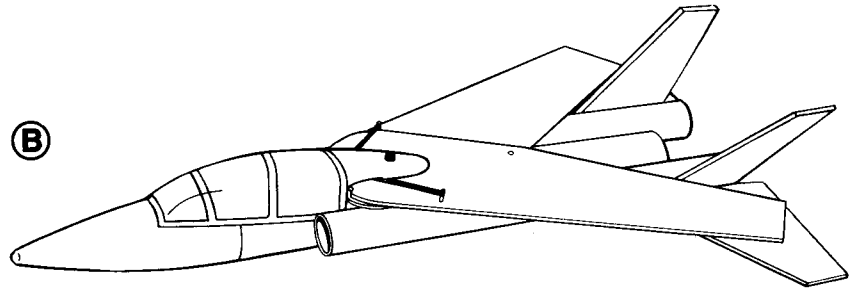

WHAT TO EXPECT WHEN FLYING YOUR TOMCAT™ ROCKET

The Tomcat™ is a rocket-boosted glider. It launches straight up like a rocket with the wings folded back. At apogee (the highest point in the rocket's flight), the wings sweep forward and the Tomcat™ begins its glide back to Earth. It turns and banks on a

random flight path so each flight is different and exciting. B6-2, C5-3, C6-3 are the best engine choices. Choose a large flying field clear of trees and obstructions.

PREPARE ENGINE

NOTE: Igniter plugs come with rocket engines. If your engines did not come with plugs, follow the instructions that came with the engines.

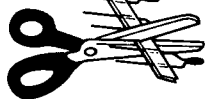

HOLD ENGINE UPRIGHT, DROP IN IGNITER

IGNITER MUST TOUCH PROPELLANT

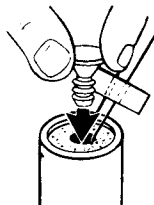
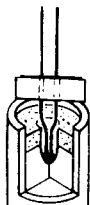

INSERT IGNITER PLUG

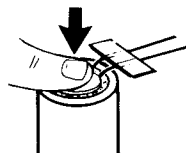

FIRMLY PUSH ALL THE WAY IN

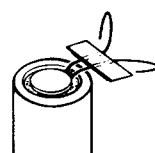

BEND IGNITER WIRES BACK

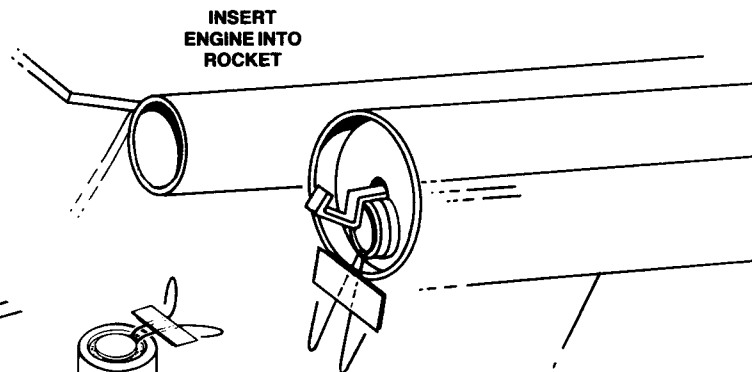

LAUNCH SUPPLIES

To launch your Tomcat™, you will need the following items:

- Estes Electrical Launch Controller and Launch Pad
- Recommended Estes Engines: B6-2 (First Flight), C5-3, C6-3

To become familiar with your rocket's flight pattern, use a B6-2 engine for your first flight. **Use only Estes products to launch this rocket.**

FLYING YOUR ROCKET

Choose a large field away from power lines, tall trees, and low flying aircraft. Try to find a field at least 152 meters (500 feet) square. The larger the launch area, the better your chance of recovering your rocket.

Launch area must be free of dry weeds and brown grass.

Launch only during calm weather with little or no wind and good visibility.

MISFIRES

If the igniter functions properly but the propellant does not ignite, keep in mind the following: An Estes igniter will function properly even if the coated tip is chipped. However, if the coated tip is not in direct contact with the engine propellant, it will only heat and not ignite the engine.

When an ignition failure occurs, remove the safety key from the launch control system and wait one minute before approaching the model. Remove the expended igniter from the engine and install a new one. Be certain the coated tip is in direct contact with the engine propellant, then reinstall the igniter plug as illustrated above. Repeat the countdown and launch procedure.

FOR YOUR SAFETY AND ENJOYMENT

Always follow the NAR* MODEL ROCKETRY SAFETY CODE while participating in any model rocketry activities.

*National Association of Rocketry

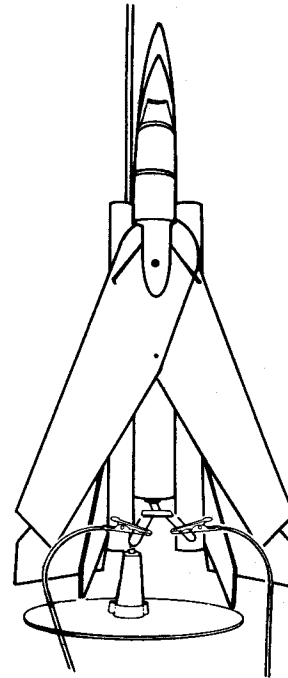

SAFETY KEY MUST NOT BE IN LAUNCH CONTROLLER WHEN ATTACHING MICRO-CLIPS TO ENGINE IGNITERS

MICRO-CLIPS NOT TOUCH BLAST DEFLECTOR OR EACH OTHER

COUNTDOWN AND LAUNCH

- ⑩ BE CERTAIN SAFETY KEY IS NOT IN LAUNCH CONTROLLER.
- ⑨ Remove safety cap and slide launch lug over launch rod to place rocket on launch pad. Make sure the rocket slides freely on the launch rod.
- ⑧ Attach micro-clips to the igniter wires. Arrange the clips so they do not touch each other or the metal blast deflector. Attach clips as close to protective tape on igniter as possible.
- ⑦ Move back from your rocket as far as launch wire will permit (at least 5 meters - 15 feet).
- ⑥ INSERT SAFETY KEY to arm the launch controller.

Give audible countdown 5...4...3...2...1

LAUNCH!!

PUSH AND HOLD LAUNCH BUTTON UNTIL ENGINE IGNITES

REMOVE SAFETY KEY FROM LAUNCH CONTROLLER. KEEP SAFETY KEY WITH YOU OR REPLACE SAFETY KEY AND SAFETY CAP ON LAUNCH ROD.

If you use the ultrasafe E2™ or Command™ Launch Controllers to fly your models, use the following launch steps.

- A. After attaching micro-clips, etc., insert the safety key into the controller receptacle. If the igniter clips have been attached properly to the igniter, the red L.E.D. will now begin to flash on and off and the audio continuity indicator will beep on and off.
- B. Hold the yellow (left) arm button down. The L.E.D. will stop flashing and the audio indicator will produce a steady tone.
- C. Verbally count down from five to zero loud enough for the bystanders to hear. Still holding the yellow arm button down, push and hold the orange (right) button down until the rocket ignites and lifts off.

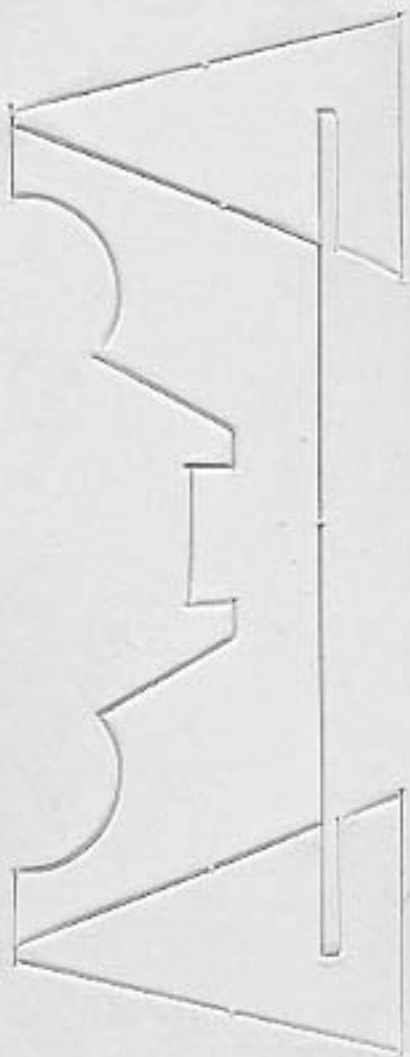

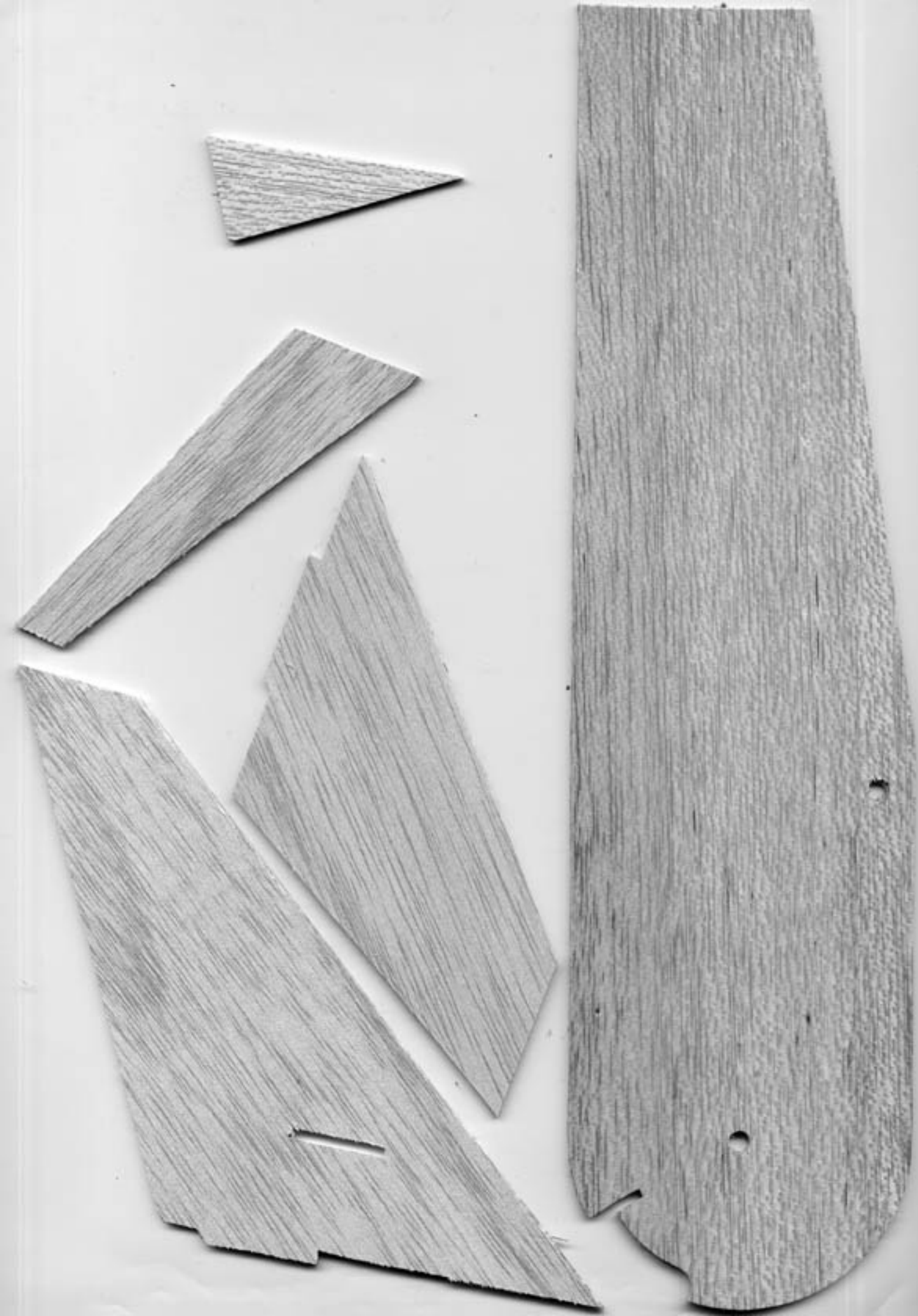

Main Body tube Diagram (not drawn to scale)

Reverse side

Distance from edge of hole to edge of hole or body tube

Hole Diameter

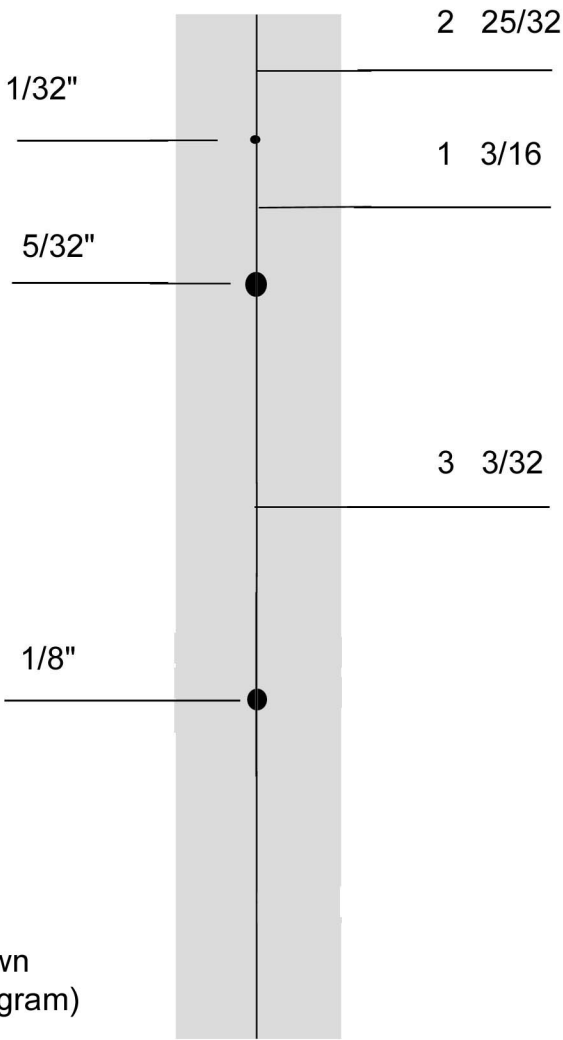
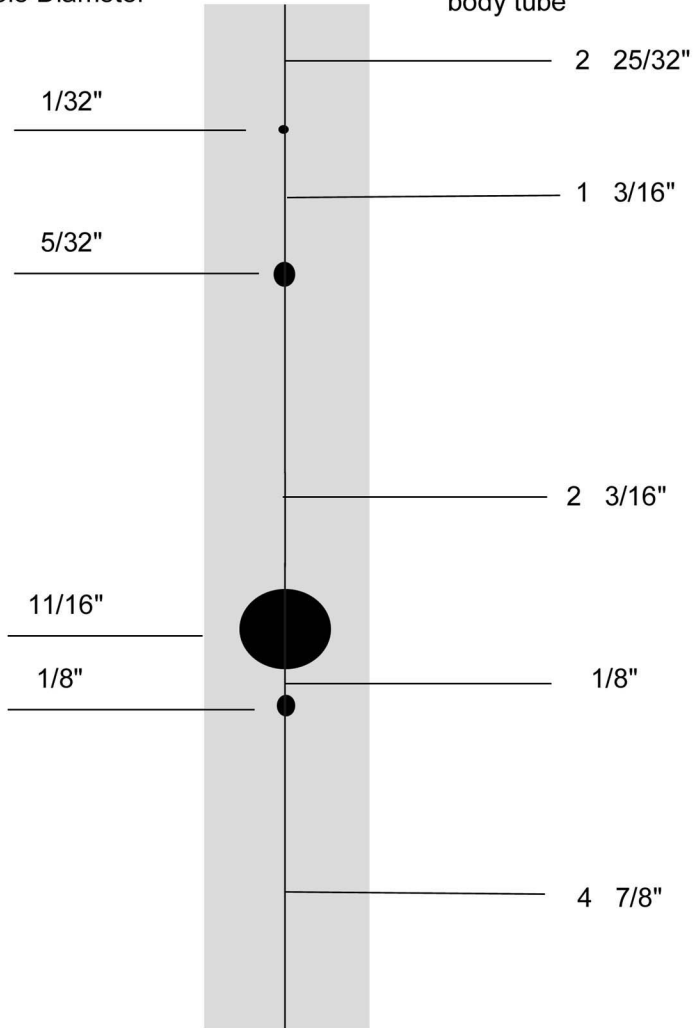

Main tube length: 12 1/2"

Side tube Length: (not shown on diagram) 12 3/4"

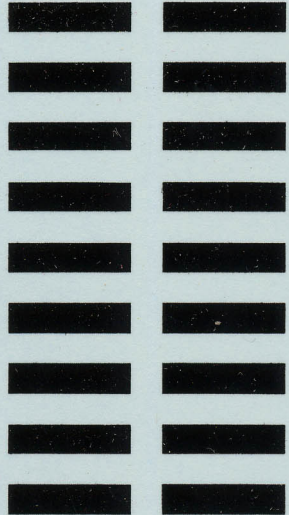

NAVY
NAVY
USAF
USAF

ES-93 ES-93 178 178

93 ES

93 ES

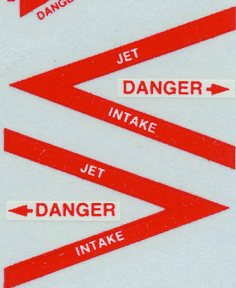

NO STEP NO STEP

TOMCAT™



ESTES IND.
PN 037601

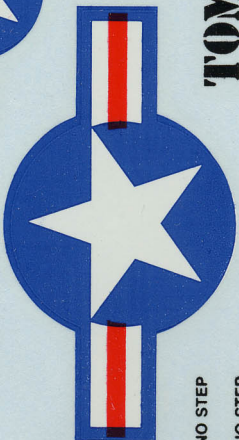
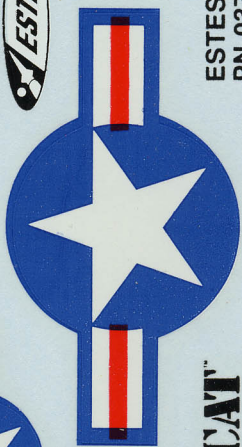

TOMCAT™

NO STEP
NO STEP

Challenge

s e r i e s

TOMCAT™ SWING-WING FIGHTER

Skill Level III
Flying Model Rocket

- Military Styling
- Rockets up to 300 ft (92 m) Altitude
- The Tomcat™ Wings Swoop Back for Fast Ballistic Climb, Then Extend for Graceful Soaring Flight
- Simple Wing Mechanism - Easy to Prep!

- U.S. Navy and Air Force Decals Included - Your Choice of Decor

Recommended for Ages 10 and up, with adult supervision for those under 12.

USE ONLY WITH ESTES PRODUCTS

MADE IN U.S.A.

This is a model of a weapon system. Use, testing, repair, engine, spare and/or other parts not included.



EST 2086



1 MODEL KIT
PRINTED IN CHINA (NEW COMPANY)



GO BALLISTIC!
● Incredible Swing-Wing Action

Length: 86.7 cm (34.13 in.)
Wingspan:
Swoop - 26.0 cm (10.24 in.)
Extended - 47.5 cm (18.69 in.)
Weight: 113 g (4.0 oz.)
Recommended Engines: C6-2
Best Flight: C6-2