

FLYING MODEL

ROCKET

SIZZLER

BETA
SERIES

Skill Level 1

- *Blazes to over 400 ft.
(over 120 meters)!*
- *Through-the-wall fins
for added strength!*
- *Flies over & over again!*

**Unique Rear
Deployed
Parachute!**



Length: 27.8" (70.8 cm)
Diameter: 1.64" (41.7 mm)
Weight: 3.9 oz. (110 grams)
Recommended Engines:
B6-2 (First Flight), B4-2, C6-3, C6-3, C6-5

Made in USA



CAUTION: Use of this Estes product with any other brand name model product containing any defect resulting any damage may void the Estes warranty.



1600 PN 62131

© Copyright Estes Industries, 1995. All Rights Reserved.



ESTES INDUSTRIES (11-96) 82100
1295 H Street
Penrose, CO 81240 EST 2127

SIZZLER[®] FLYING MODEL ROCKET KIT INSTRUCTIONS

BETA[™] SERIES SKILL LEVEL 1

TOOLS REQUIRED:

WHITE OR YELLOW GLUE, TUBE-TYPE PLASTIC CEMENT, RULER, PENCIL, HOBBY KNIFE,
400-600 GRIT SANDPAPER, WAXED PAPER, MASKING TAPE, WHITE & YELLOW SPRAY PAINT

ALL GLUED AREAS ARE SHADED IN GRAY

PARTS LAYOUT

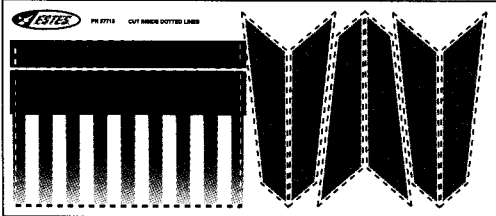

DECAL (1)
37715

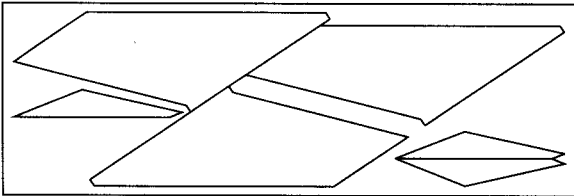

DIE CUT Balsa FIN SHEET (1)
32252

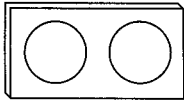

DIE CUT CARD (1)
32477

LARGE ADAPTER RINGS #5560 (2)
30001

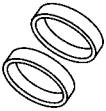

LAUNCH LUGS #LL2A
38175

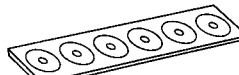

TAPE RINGS (1)
38407

INNER TUBE #55G (1)
30386



SHROUD LINES #108 (1)
38239

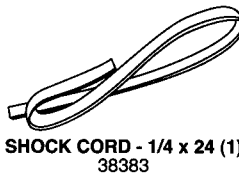

SHOCK CORD - 1/4 x 24 (1)
38383

ENGINE TUBE #760 (1)
31700

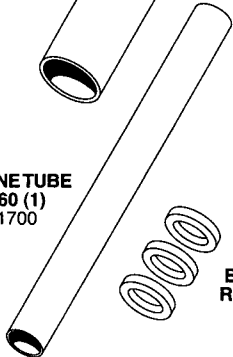

ENGINE MOUNT RINGS #76055 (3)
30133

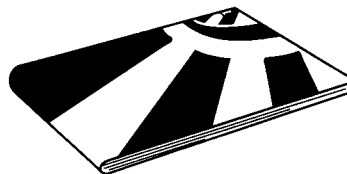

PARACHUTE - 18 (1)
35821

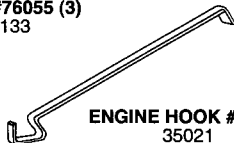

ENGINE HOOK #2A (1)
35021

NOSE CONE #60RL (1)
72305

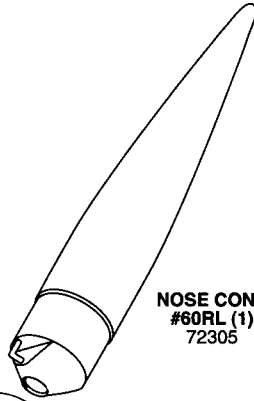

SLOTTED BODY TUBE #60WH (1)
31175

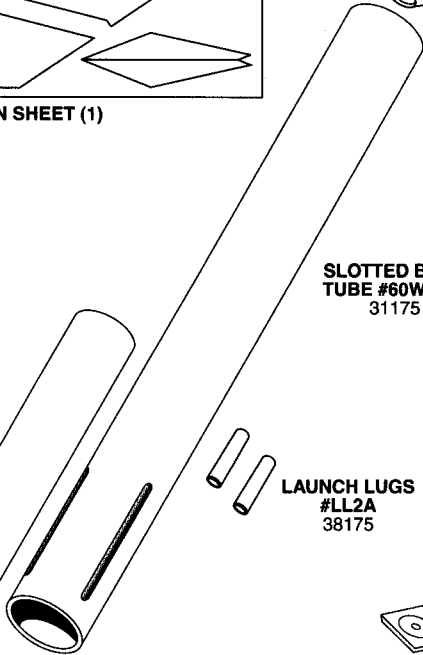

1. INNER TUBE ASSEMBLY

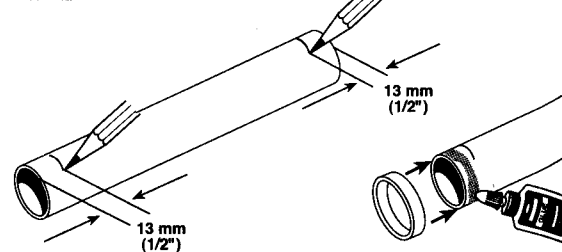

- A. Use a ruler to mark inner tube at 13mm (1/2") from each end.
- B. Apply a band of glue to the end and slide one of the adapter rings through up to mark.

2.

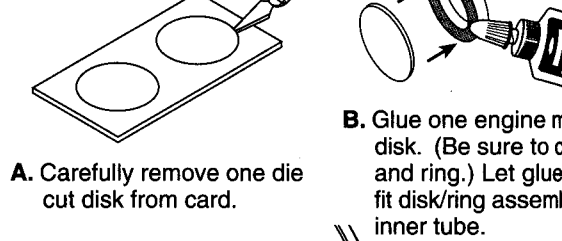

- A. Carefully remove one die cut disk from card.
- B. Glue one engine mount disk. (Be sure to center disk and ring.) Let glue dry. Then fit disk/ring assembly into inner tube.

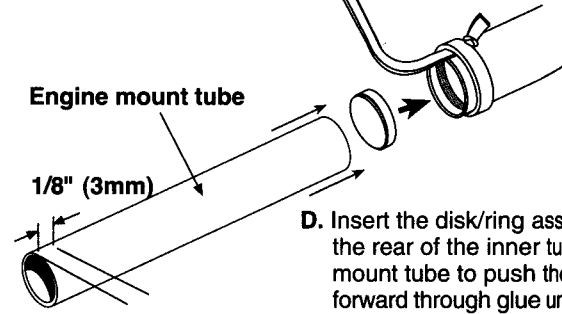

- D. Insert the disk/ring assembly into the rear of the inner tube. Push the inner tube forward through glue until the disk/ring assembly is flush with the front of the engine mount tube. Immediately remove the inner tube.

4.



- A. Using the balsa stick, apply glue inside the body tube just in front of the slots as shown.
- B. Insert front end of inner tube into rear (slotted) end of body tube, then slide inner tube in until ring is flush with end of tube.

NOTE: You may want to apply a glue fillet to front adapter ring.

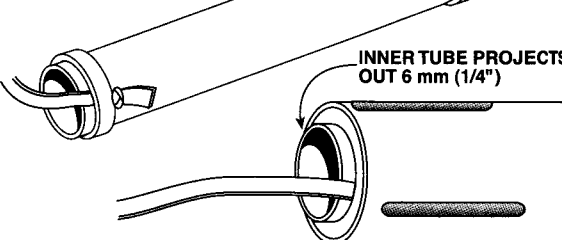

INNER TUBE PROJECTS OUT 6 mm (1/4")

C. Tie a double knot in both ends of shock cord.

D. Apply glue to other end of tube.

E. Lay one knotted end of shock cord in glue. Put other end of shock cord through a large adapter ring and slide ring up to the other 13mm (1/2") mark. (This is now the rear of the inner tube assembly.)

F. While holding adapter ring in place, pull cord so knot rests up against adapter ring tightly. Let glue dry.

C. Apply a band of glue inside the rear (end with shock cord) of the inner tube.

E. Set tube on its side to dry completely.

3.

A. Fine sand balsa fin sheet.

B. Use a hobby knife to carefully complete cuts in balsa fin sheet. Cut away from adjacent fins so you won't damage them. (Be sure cuts go completely through balsa.)

C. Carefully remove fins. (Save a stick of balsa to use later as a glue applicator.)

D. Stack fins together and sand all edges smooth.

E. Lay fin pieces on a sheet of waxed paper. Glue together. (Be sure to glue the small fin piece set back from the large piece fin tab.)

F. Set each fin assembly aside to dry.

GLUE

OBJECTS

5.

NOTE: Before gluing, test fit fins into slotted body tube. Sand tabs as necessary.

A. Apply a thin film of glue to root edge of fin. Allow glue to set for a minute.

B. Apply another, thicker layer of glue to same fin.

C. Set the rear end of the root edge even with the rear of a slot in body tube and gently press the root edge into slot. (The small section of the fin will sit outside the slot on the body tube.) Apply remaining fins in same manner.

D. After fins are attached, check for proper alignment.

E. IMPORTANT: Stand rocket on front end until glue is completely dry.

6. ENGINE MOUNT ASSEMBLY

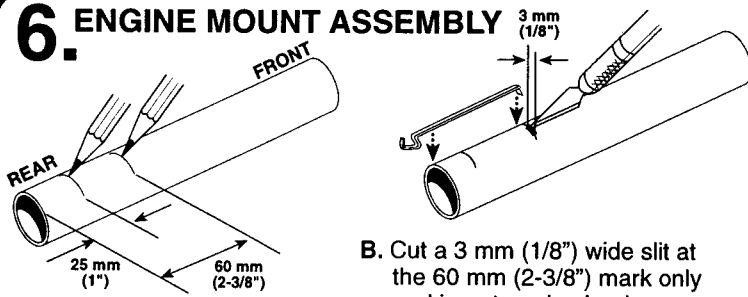

A. Mark the engine mount tube at 60 mm (2-3/8") and 25 mm (1").

B. Cut a 3 mm (1/8") wide slit at the 60 mm (2-3/8") mark only and insert engine hook as shown. This is now the rear of the engine mount.

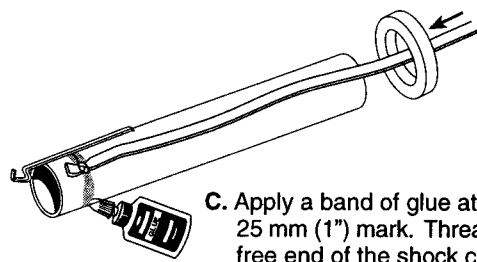

C. Apply a band of glue at the 25 mm (1") mark. Thread the free end of the shock cord through an engine mount ring with knot toward rear of tube. Lay cord onto glue.

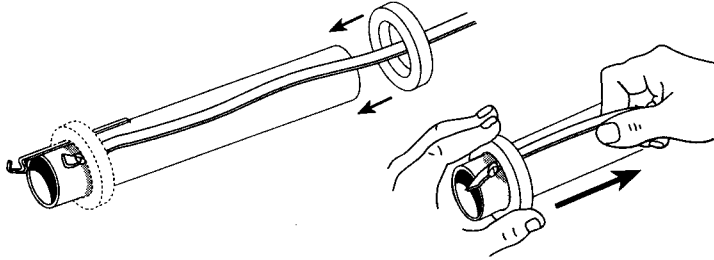

D. Slide the engine mount ring down the tube, over shock cord to 25 mm (1") mark. Hold the ring in place and pull knot tight against engine mount ring.

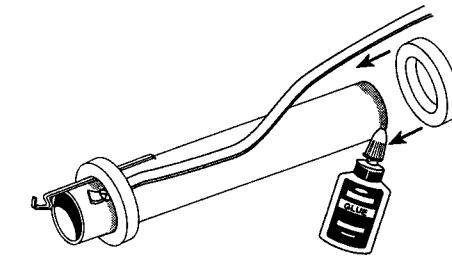

E. Apply a band of glue around the front end of the engine mount tube. Move shock cord out of the way and slide remaining engine mount ring onto front end of tube until edges are even. Set assembly aside to dry.

9.

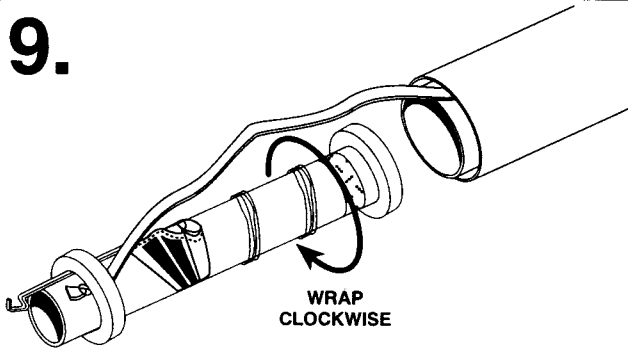

E. Move shock cord out of way and spiral wrap lines and parachute down engine mount tube between two rings.

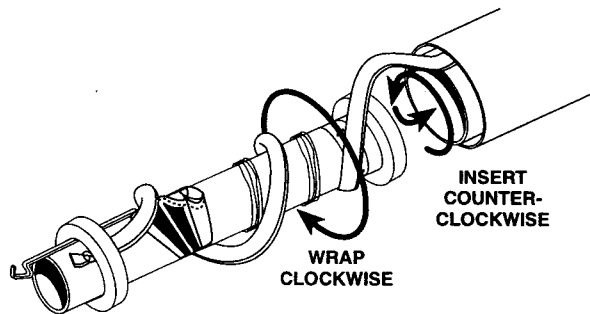

F. Again move the shock cord out of the way and insert front of engine mount into body tube. Wrap any excess shock cord around engine mount tube between rings and insert rest of engine mount into body tube. (It may be helpful to use a twisting motion while inserting mount in order to keep chute wrapped around engine mount.)

7.

A. Cut out p on dotte



B. Find shroud line the shroud line,

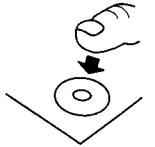

C. Press tape rings onto marks on corners.



COMP
PARA

10.

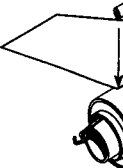

A. Apply a thin l lug. Align lug glue into a fir

11.

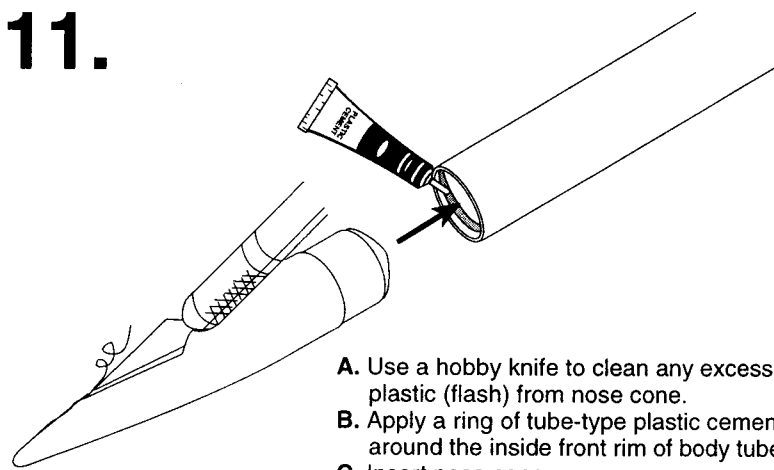

A. Use a hobby knife to clean any excess plastic (flash) from nose cone.
B. Apply a ring of tube-type plastic cement around the inside front rim of body tube.
C. Insert nose cone.

12.

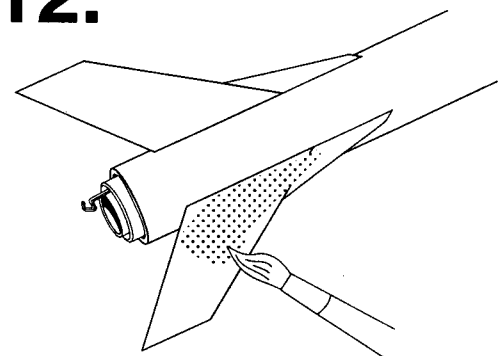

A. Use sanding sealer to fill and smooth balsa fins. (You may want to sand with 400-600 grit sandpaper and re-apply sealer until you are satisfied with finish.)

Cut out parachute
dotted line.



Remove tape. Using all of
shroud line material, fold and cut into three equal lengths.

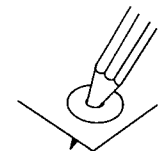
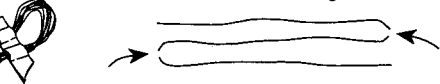

D. Punch holes
with sharp
pencil.

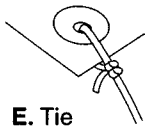

E. Tie
lines
off.

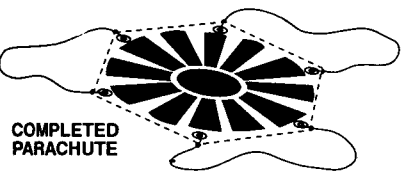

COMPLETED
PARACHUTE

8.

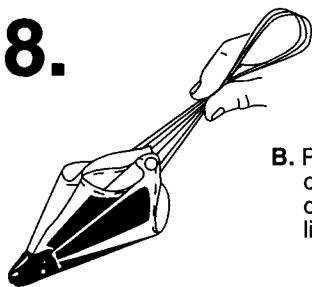

A. Form loop with
shroud lines.

B. Place front end
of engine mount
over shroud
lines.

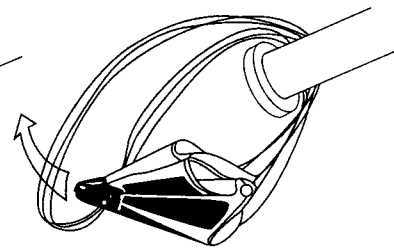
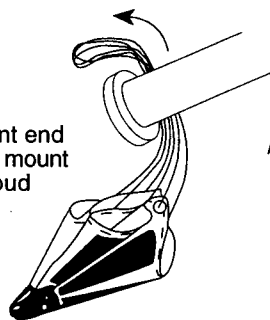

C. Pass parachute through loop.

D. Pull tight.

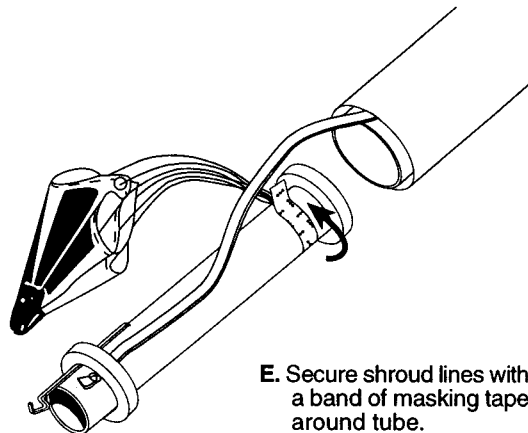
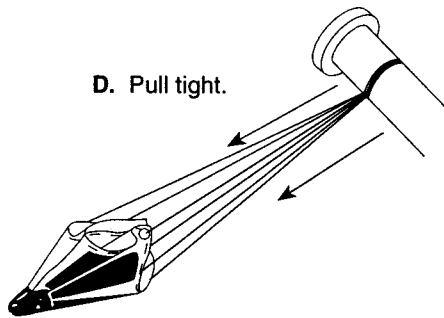

E. Secure shroud lines
with a band of masking tape
around tube.

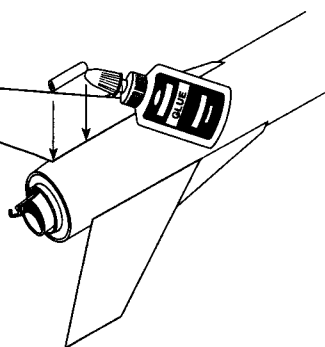

Apply a thin layer of glue to side of launch
lug with rear edge of one fin and
to a fin body joint.

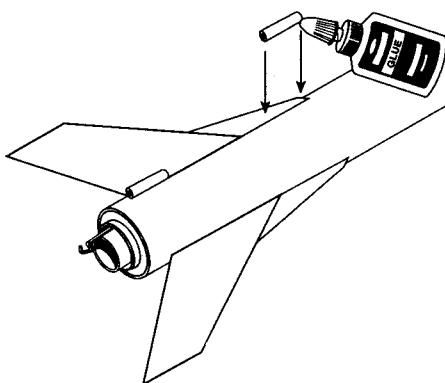

B. Apply a thin layer of glue to side of
other launch lug. Align front end of lug
with top of same fin and apply.

NOTE: BE SURE FILLET DOES NOT
INTERFERE WITH LAUNCH ROD
PASSING THROUGH LUGS.

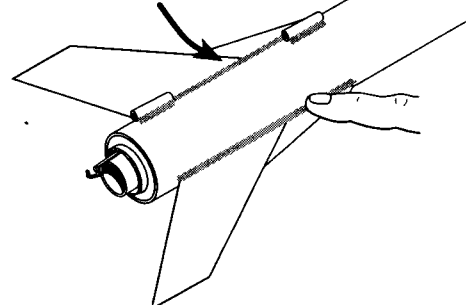

C. Apply a glue reinforcement (fillet) to
lugs and fin joints. Let dry.

B. NOTE: For a smooth finish, first
apply a thin coat of automotive
primer to entire rocket.
Paint entire rocket white enamel.
(Do not overspray.) Let paint dry
completely.

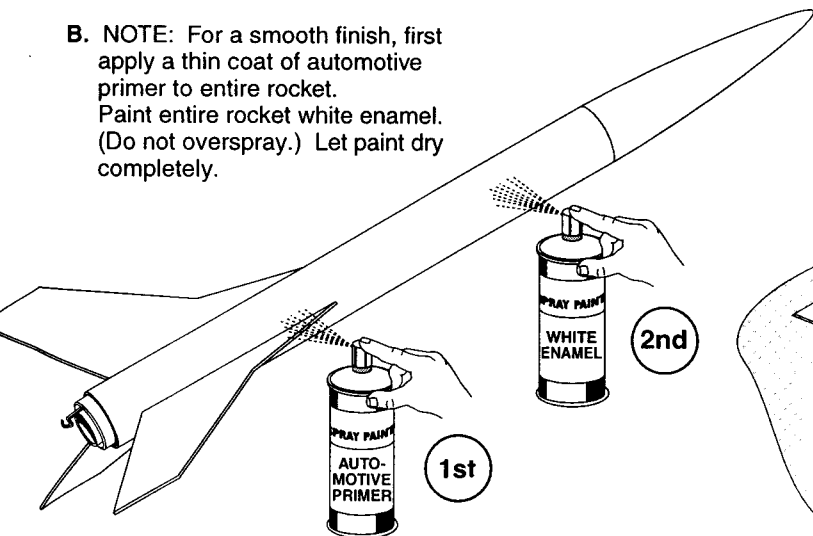

C. Mask and tape a plastic bag around
rear 3/4 of rocket and paint front 1/4
of rocket yellow. Let dry completely.

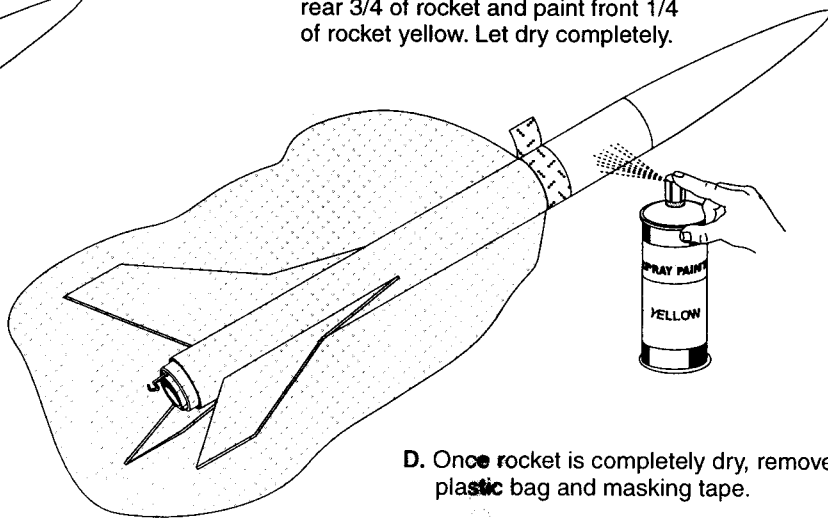

D. Once rocket is completely dry, remove
plastic bag and masking tape.

13.

APPLYING DECALS

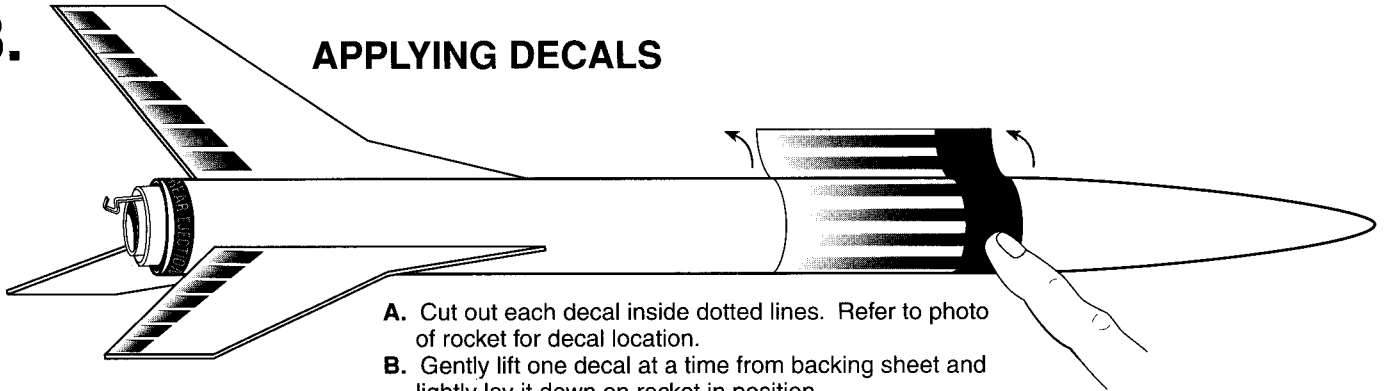

- A. Cut out each decal inside dotted lines. Refer to photo of rocket for decal location.
- B. Gently lift one decal at a time from backing sheet and lightly lay it down on rocket in position.
- C. When position is correct, rub decal down with your finger to remove bubbles and to secure decal to rocket.

14. FLYING YOUR ROCKET

ENGINE PREPARATION

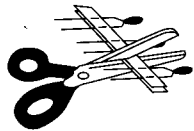

Separate igniter and igniter plug.

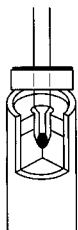
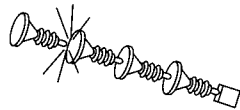

Hold engine upright, drop in igniter. Igniter must touch propellant.

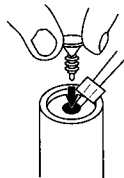

Insert igniter plug.

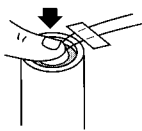

Firmly push all the way in.

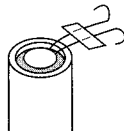

Bend igniter wires back.

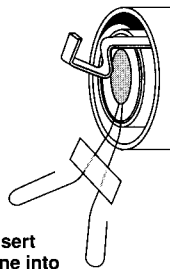

Insert engine into rocket.

15. FLIGHT PROFILE

- 1. The Sizzler® rocket features rear ejection of the recovery system. The power pod is also ejected but returns with the rocket as one assembly.
- 2. Recovery wadding is not required for this rocket. See steps 8 and 9 for recovery system preparation.

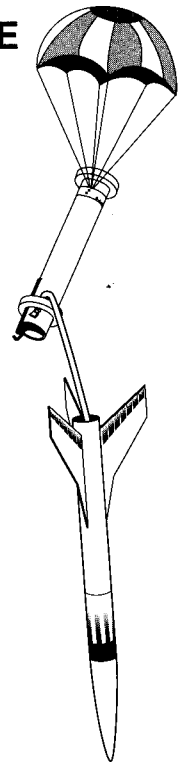

NOTE: When flying your Sizzler®, be sure the shock cord is inserted and protected by the power pod.

LAUNCH SUPPLIES

To launch your rocket, you will need the following:

- Launch Pad (Estes Porta-Pad® II)
 - Launch Controller (Estes Electron Beam®)
 - Recommended Estes Engines: B4-2, B6-2, C5-3, C6-3 or C6-5. Use the B4-2 for your first flight to become familiar with your rocket's flight pattern.
 - Igniters and Igniter Plugs (included with Estes engines)
- Use only Estes products to launch this rocket.

TIPS FOR FLYING YOUR ROCKET

- Choose a large field away from power lines, buildings, tall trees, and low flying aircraft. Try to find a field at least 76 meters (250 feet) square. The larger the launch area, the better your chance of recovering your rocket.
- Launch area must be free of dry weeds and brown grass.
- Launch only during calm weather with little or no wind (wind speed less than 30 kph - 20 mph) and good visibility.
- Don't leave parachute packed more than a minute or so before launch during cold weather (colder than 4° Celsius [40° Fahrenheit]). Parachute may be dusted with talcum or baby powder to avoid sticking.
- Always follow the National Association of Rocketry (NAR) MODEL ROCKETRY SAFETY CODE while participating in any model rocketry activities. The safety code is enclosed with this kit.

ENGINE	PROJECTED ALTITUDE	
	Feet	Meters
B4-2	120	37
B6-2	135	41
C5-3	390	119
C6-3/C6-5	366	112

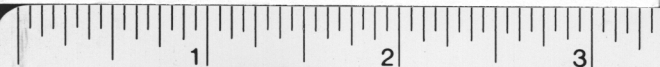
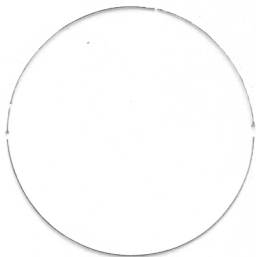
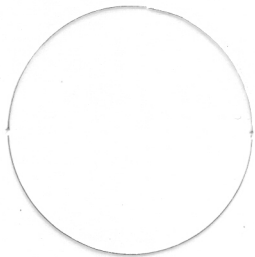

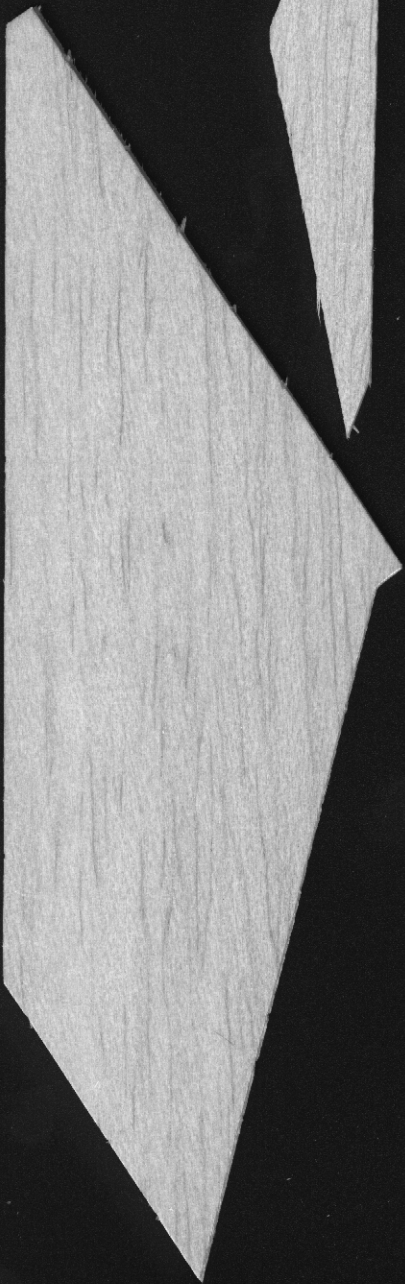
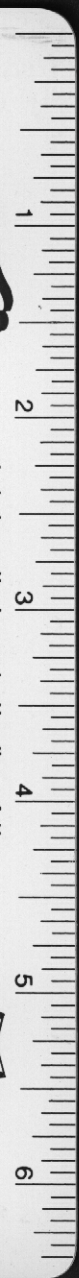



PN 37715

CUT INSIDE DOTTED LINES

REAR EJECTION REAR EJECTION

