

# MODEL ROCKET NEWS

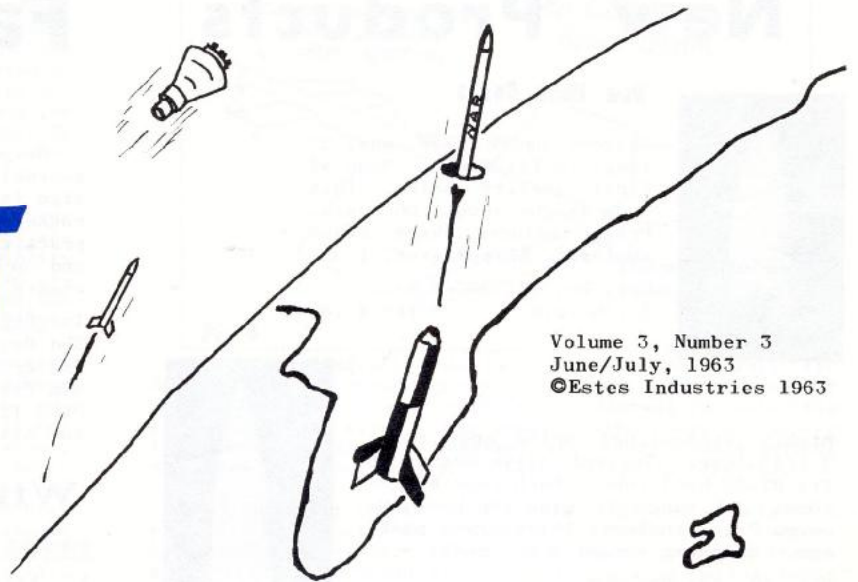

Volume 3, Number 3  
June/July, 1963  
©Estes Industries 1963

## Rocketeer of the Month

A model rocketeer can look on his sport as an amusement, a hobby, or a scientific study. Taking the last approach, Roy Schmidt of Denham Springs, Louisiana, has won an impressive group of awards in science fair competition.

Roy, then a Junior at Denham Springs High School, entered the Region 8 science fair on March 15 with a project entitled "Reducing Drag on an Astro-Dynamic Vehicle." He won first place in physics. Then on March 23 he entered his paper at the regional meeting of the Louisiana Junior Academy of Sciences, and again won a first place. Then to round out his accomplishments, he received the NASA award for "best project in aerodynamics" at the state science fair. His project proved the value of a smooth finish in improving the performance of rockets.

Racking up awards isn't his only interest. He plans on becoming an astrophysicist and is already taking steps to qualify himself. Last year, among other subjects, he studied chemistry and algebra II, and this year he will include advanced mathematics and physics in his work.

Roy is also active in his school's science club, and is president of the Heaven-Bound Rocketeers, Louisiana's leading model rocket club. The Model Rocket News is proud to name this forward-looking modeler "Rocketeer of the Month."

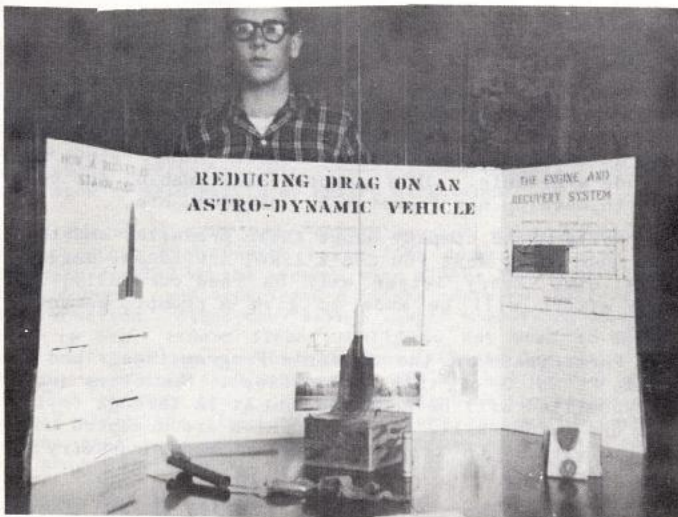

## Moonnik Chosen Top Odd Ball

The Moonnik I, designed by Norman Foster of Portland, Oregon, took top honors in the recent Odd Ball Contest held by Estes Industries. Taking the odd ball idea literally, Foster designed a rocket that looks like a sputnik satellite, yet flies quite well. The design for the Moonnik I appears on page 8.



A student at Woodrow Wilson High School in Portland, Foster is an active model aviator, and with the advent of model rocketry, took up that field also. His career interests include science and engineering.

Second place in the contest went to Danny McCoy of Gadsden, Alabama for his Wrong Way Corrigan II, a rocket which appears upside down when on the launcher, but transforms to a normal configuration after ignition. Michael Roth of Tucson, Arizona took third place with his box-finned Whamadoodle, while fourth place went to Jim Scothorn of Cherokee, Iowa for The Bug, which was designed to resemble an insect.

In summing up the contest results, the judges commented that the contest entries showed the greatest diversity of thinking yet seen in an event of this nature, and stated that they felt all entrants deserved the highest praise for their originality.



# New Products

## New Nose Cones



Tangent ogive nose cone, 2" long, to fit BT-30. Made of first quality balsa, this cone weighs about .06 ounce. Price includes third-class postage. Shipping wt. 1 oz.

Cat. No. 631-BNC-30M  
\$ .40 each      3 for \$ .80

Highly streamlined balsa nose cone, 3 1/4" long. Tangent ogive design to fit BT-30 body tube. Each cone weighs about .08 ounce to give top performance. Price includes third-class postage. Shipping weight 1 oz. each.

Cat. No. 631-BNC-30N  
\$ .45 each      3 for \$ .90



## Styrofoam Balls

Extremely lightweight 3" dia. styrofoam balls for use in the Sputnik-Too and similar model rockets. Use white glue #WG-1 when gluing to protect the plastic material. Price includes third-class postage. Shipping weight 5 oz. each.

Cat. No. 631-SB-3      \$ .25 ea.



## Maple Dowels

Select, seasoned 18" long by 1/8" diameter maple dowels. Give exceptionally high strength with low weight. Stocked especially for use in the Sputnik-Too, the inventive rocketeer will find many other uses for them. Price includes third-class postage. Shipping wt. 5 oz.

Cat. No. 631-WD-1      4 for \$ .20

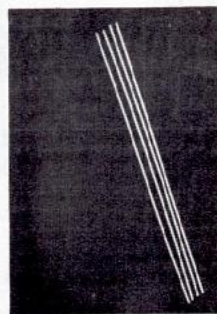

## Writer's Program in Operation

Included in this issue are the first Writer's Program articles accepted for publication, "Fins," by Dean Black of Brigham City, Utah, on page 3, and "Rear Engine Boost Gliders," by Gordon Mandell of Great Neck, N.Y., on page 10.

Both articles demonstrate the technical competence of the writers, and both contain highly valuable information for beginners and experienced rocketeers alike. In selecting these articles, the editors took into consideration not only the quality of the writing, but also the fact that each article covers an area in which relatively little published material previously existed, and were the results of personal research.

Information on the Writer's Program appears on page 2 of the September/October 1962 issue of the Model Rocket News. For those interested in writing and submitting articles for the program, the editors recommend reading chapters 2, 8, and 12 of Technical Writing by Richard W. Smith. This book is published by Barnes and Noble, Inc. as a part of the College Outline Series, and can be obtained through most leading book stores.

# Favorite Design Contest

Do you have a favorite rocket that you have designed yourself? If so, this contest is for you. If your design is picked by the judges, you may win up to \$50 in rocketry supplies. Entries will be judged on neatness, practicality, unusual features, soundness of design, and originality. So start work now to have the best chance of winning.

1st Prize--\$50 in merchandise credit.  
2nd Prize--\$25 in merchandise credit.  
3rd Prize--\$10 in merchandise credit.  
4th Prize--\$5 in merchandise credit.  
PLUS five fifth place winners will receive Astron Phantom kits!

## Win FREE Merchandise!

### CONTEST RULES

- 1) All plans must be drawn to scale. Pencil or ink drawings are acceptable.
- 2) A parts list must accompany entry.
- 3) All entries must be flight tested to assure that they have suitable flight characteristics.
- 4) Only single stage designs will be qualified.
- 5) The center of pressure and center of gravity of the rocket must be marked on the plans.
- 6) Sufficient information must accompany entry to allow judges to build an exact duplicate of the original model.
- 7) The decision of the judges is final.
- 8) Entries must be postmarked no later than midnight, September 30, 1963.
- 9) All plans submitted become the property of Estes Industries, Inc., and no plans or designs will be returned.

## THE MODEL ROCKET NEWS

Vernon Estes      William Simon      Gene Street  
Publisher      Editor      Illustrator

The Model Rocket News is published approximately six times annually by Estes Industries, Inc., Penrose, Colorado. It is distributed free of charge to all the company's mail order customers from whom a substantial order has been received within a period of one year. The Model Rocket News is distributed for the purpose of advertising and promoting a safe form of youth rocketry, and for informing customers of new products and services available from Estes Industries. Rocketeers can contribute in several ways towards the publication of the Model Rocket News:

- (1) Write to Estes Industries concerning things you and your club are doing in this field which might be of interest to others.
- (2) Continue to support the company's development program by purchasing rocket supplies from Estes Industries, as it is only through this support that free services such as the Model Rocket News, rocket plans, etc., can be made available. This support also enables the company to develop new rocket kits, engines, etc.
- (3) Write to the company about their products, and tell what you like, what you don't like, new ideas, suggestions, etc. Every letter will be read carefully, and every effort will be made to give a prompt, personal reply.
- (4) Participate in the Writer's Program (described in Volume 2, No. 3 of this publication). Not every article submitted will be accepted, but it is through trying that one gains skill, and those which are accepted contribute greatly to the enjoyment of model rocketry by other persons also.



# FINS

by Dean Black

Fins are among the most important parts of almost any model rocket. They guide the rocket so that it will do what the modeler wants it to do. Still, many rocketeers are not fully aware of what fins do, and how they should be constructed for best results. There are some basic principles and applications of fins to model rockets of which all rocketeers should be aware.

## STRUCTURAL STRENGTH:

A fin should always be cut so that the grain of the wood is parallel to or almost parallel to the fin's leading edge. The wood grains should run into the body tube when the fins are glued in place.

Of course it is important that a fin be glued solidly in place, but the joint must be extra strong at the maximum stress point. This point of maximum stress is

**Fig. 1** Point of maximum stress on fin of any Rocket

**Fig. 2** Side profile of fin. Leading Edge Symmetrical Airfoil

**Fig. 3** Least efficient Better Most efficient

For most Stability, place the CP of fins as far behind the CG as your design will allow.

**Fig. 4** Spin-fin. These will spin your Rocket quickly and provide Gyro-stabilization, especially good with clustered engines.

**Fig. 5** Too much angle spoils air-flow - causes drag and unstable spin.

**Fig. 6** Non symmetric airfoil - spins slowly at first... not recommended for Rockets not normally stable without spin.

the point where the leading edge comes into contact with the body tube. A weak hold in this area may result in loss of the fin. (See figure 1.)

## EFFICIENCY:

Streamlining is important to any external part of a rocket. Fins are certainly no exception to this rule. The fins should be smoothly sanded to match the side profile shown in figure 2. It is always a good idea to use sanding sealer and steel wool or fine sandpaper to fill in the pores of the wood and give the fins a smooth finish.

The further behind the center of gravity a fin is, the more efficiently it will work. When the fins are moved farther behind the rocket's center of gravity, the rocket's stability is increased. Figure 3 shows how fins of different designs, but with approximately equal areas, vary in efficiency. Notice how the fin's average distance from the center of gravity coincides with its efficiency. Never put fins on the forward end of a rocket ahead of the center of gravity. This will decrease the rocket's stability instead of increasing it.

## SPIN FINS:

Spin fins are used for two basic purposes. They provide the principle means of stabilization in some rockets. In other rockets, especially those using clustered engines, spin fins are used to keep the rocket on a truer course.

For rockets which depend a great deal on the spinning motion for stabilization, angled spin fins are best. (See figure 4.) Angled fins produce a fast spin almost immediately. The best way to fit angled fins to the body tube is to run the inside edge of each fin along a piece of sandpaper wound around a body tube or empty engine casing. After sanding the fins in this fashion, they should fit snugly against the body tube. Never place fins at an angle of more than 15°. The air can not flow around the fins properly when the angle is greater, and it will tend to create turbulence as in figure 5. This will result in increased drag and an unstable spin.

For rockets which only rely on the spin for minor purposes, such as maintaining a somewhat straighter flight path than could otherwise be expected, the segmented-wing design shown in figure 6 is best. Fins of this design create much less drag than angled spin fins. In fact, they create little or no more drag than ordinary fins. Segmented-wing fin units do not produce a fast spin at first, as do the angled spin fins. For this reason such fins should not be used on rockets that would not be reasonably stable without the assistance of the spinning motion. Segmented-wing fins may be angled for a faster spin, although this brings the drag up again.





# NOTES FROM THE BOSS



The recent Odd Ball contest proved to be the most interesting contest yet held by Estes Industries. What value is such a contest? Some might suggest that building such things is a waste of time and seems of no practical value.

While none of the designs entered is likely to replace the more conventional rocket one important step was taken by each designer. In order to arrive at the new design his old ideas of what a rocket looked like had to be discarded. Then using basic scientific information a new design was developed which worked but which had little or no resemblance to a standard rocket.

This could be compared with the type of research and development required when the jet engine was invented to replace the piston engine or when the transistor was developed to replace the vacuum tube. Although less spectacular (in most cases) than the above examples, considerable progress and invention were accomplished by each entrant. Experience of this nature will be extremely helpful to the individual who takes up engineering as a career.

Hey, you fellows! The new FAA regulations are not made to curb your activities. As a matter of fact, after careful consideration the Federal Aviation Agency made the following statement virtually endorsing the safety of model rocketry:

"...and have exempted model rocketry from regulation herein if certain conditions are met. Typically, model rockets are made of paper, wood, or fragile plastic, contain no substantial metal parts, and are powered by a pre-mixed propellant. Under these conditions, provided reasonable weights are not exceeded, no real hazard appears to exist and this proposal would not govern such operations." (The weight limitations are 4 ounces of propellant and 16 ounces overall weight.) These regulations do restrict the launching of all metallic rockets and amateur rockets.

The New Rocketeer Contest announced in the April/May issue of the MRN is still running. With 29 big prizes being offered you can't afford to not enter. Just round up all the new rocketeers you can find and get them to place an order for \$3.00 or more with Estes Industries. Next, list them on an 8 1/2" x 11" sheet(s) and see that it's mailed to us before September 7, 1963. For more details see the April/May issue of the MRN, or, if you don't have one, write and ask for it (see the Clip 'n' Mail section).

Do you want to have a better MRN? Do you want better rocket supplies? If so, be sure to fill out and send in the questionnaire with this issue. Your opinions are very important, and we can't improve our services if we don't know what you want improved, what you like, and what you don't like.

When you fill out the survey sheet, you're voting on the company's policy, and helping to form any new policy that might be needed. So we hope you'll send in your vote right away.

# LETTER SECTION



I have just received a catalog from your Company and I would like to know if you have a book of formulars, I like to mix my own ingredience I have a few formulars of my own, but the last experiment I held was a flop, the fuel turned out to be an explosive instead of a rocket fuel. I am not some little kid so please don't send me any kids formulars.

Truely Yours  
(name withheld)

The letter above is complete as we received it, including the spelling. If you still want to mix your own "formulars" after reading the safety report on page 6, have your doctor get your blood type so that there will be a shorter wait for a transfusion after the next explosion.

-----Vernon Estes

...I built my Astron Ranger and test flew it with 3 A.8-4 engines and it took off fine but did not reach extreme altitude. So I told my wife I was going to buy a white rat and send him up. However, I looked all over Durham and could not find one, so I got a hamster instead, and named him Estes. I checked him and handled him a few days, and this morning I loaded my Ranger with 3 B3-5's and put Estes in the payload compartment.

I called out a few of the neighbors to watch, gave the countdown, and pressed the switch, and the Astron Ranger took off like lightning (I used all nichrome ignition), and just about went out of sight. At the apex of the flight the payload section popped out and both 'chutes opened, and Estes began his slow descent back to the ground. He fell about 1/4 mile from where I launched him.

When we opened the compartment, there was Estes with his whiskers wiggling. He didn't have a scratch or suffer any effects.

Walter B. Taylor  
Durham, N.C.

...And then at 750 feet on your way down, you get the urge to nibble some cabbage. . .

-----Vernon Estes

I am working on a rocket for a science project and I would like to know how far a rocket will travel if it has one pound of black gunpowder as fuel. I would appreciate any additional information on model rockets.

Raymond Harness  
Oliver Springs, Tenn.

With one pound of black gunpowder for fuel, the rocket should travel several hundred feet in all directions at once. A young "rocketeer" in Phoenix only used one half pound, and that was more than enough to kill him. One pound, or any other amount of home-loaded black powder is not by any flight of the imagination a part of model rocketry, but simple suicide. If we thought the "pound your own" system was safe, we'd sell chemicals, as there's still quite a demand for them. But the record shows that home-compounded and loaded propellants are among the most dangerous substances known to man.

-----Vernon Estes



Our zip code number is 81240

When sending orders, letters, etc.,  
be sure to use our full address:

**ESTES INDUSTRIES**

**BOX 227**

**PENROSE, COLORADO, 81240**

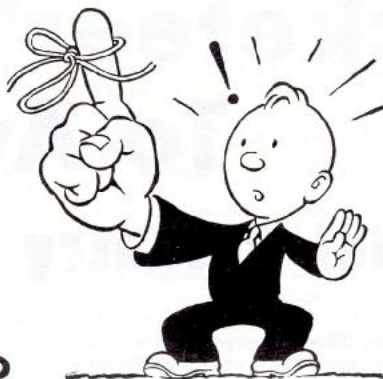

Send us your zip  
code number with  
your next order to  
be sure you get  
the fastest service  
possible!

Slip-on Launch-Lug. When building Your Rocket for "Fly and Eye," try this way of mounting -- especially recommended for You scale-model fans. For less drag, use a thin-wall collar of stiff paper. Form this paper around body-tube and glue as shown....

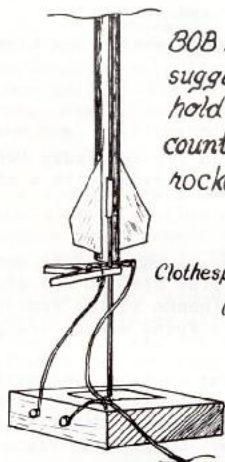
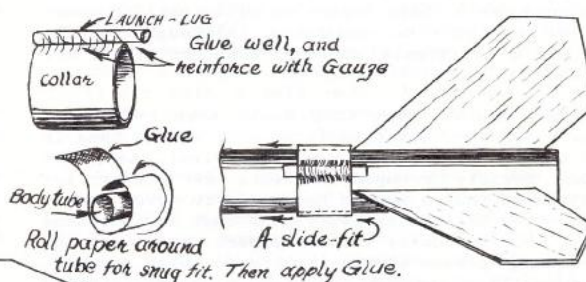

BOB FLINT, Shawnee Mission, Kansas suggests a clean and easy way to hold a rocket off the wiring during countdown, if the fins do not hold rockets-end off of the launch-pad.

Clothespin clipped on launch-Rod at desired height.  
(however, we add that it should be a wooden, spring-clip type)

1/4" Section of Engine Casing serves as Saw here



Spent Engine Casing (fits BT-20 only) Install in same way as you would a commercial block.

So many have suggested this, it would be impossible to acknowledge you all, personally, in the space available. So... Our Thanks to All of you!

Had problem of a loose launch-rod joint on your set-up? Our Editor did -- fixed it in the field too. He cut a 1/4" piece of Rosin-core solder... dropped it in the socket-- and inserted the top section next as shown. Then, he held a kitchen match to the joint 'till the solder melted. He then pressed the top section "home" sweat-soldering the two pieces.

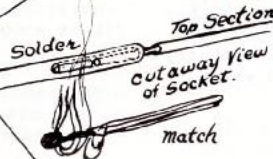

Have your shroud-lines TANGLED lately? Well, thanks to BILL ALEWINE and friend, of Augusta, Ga... a button may solve your problem...

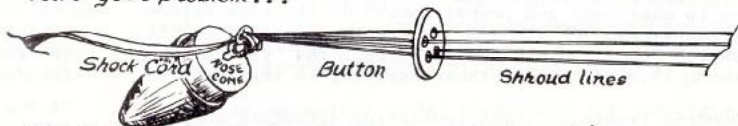

Illustrated is the rigging for a square chute. However, 6 or 8 shroud-lines may as easily be rigged by threading as we show here:

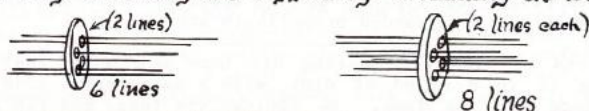

# The Idea Box

Speaking of 'Chutes, here's one more way of securing shroud-lines to the "Silk"...

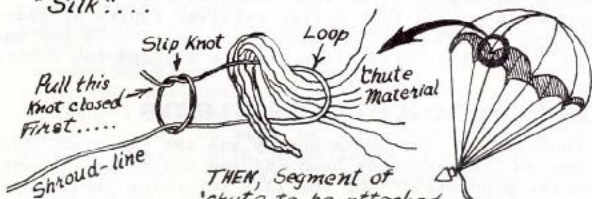

THEN, Segment of 'chute to be attached, is passed thru Loop, then over one side of loop, then back thru the loop, as shown. Finally, draw loop tight.

**REMEMBER**... The "Gimick" or "Short-cut" you may have thought of as "not worth mentioning," MAY be just the bit of help needed by a Fellow Rocketeer. So, send in your suggestion, % Estes Industries, Inc., P.O. Box 227, PENROSE, COLORADO -- Attention: EDITOR M.R.N.



# A Rocketeer's Guide To Avoid Suicide

## How Model Rocketry Prevents Accidents

There are in this country today three groups of non-professional rocketeers--Basement Bombers, Amateurs, and Modelers. The separation between the first two groups is not clearly defined, for both bombers and amateurs engage in hazardous operations, the basement bomber often without realizing the danger, the amateur often in spite of the danger. For the purposes of this report we will consider basement bombers and amateurs as one group. Although there is such a thing as a legitimate amateur rocketeer, there are very few of them.

Surgeons today can do much that would have required a miracle a few years ago, but this is no help when a hand is missing, and even less for the dead-on-arrival case. The American Rocket Society grouped amateurs and bombers together and estimated that a person has a one in seven chance of being injured or killed for every year that he continues his activities. Almost daily the newspapers report the injury of some young person who was trying to build a rocket with his own propellant, and many injuries are never reported in the news.

In contrast, there is a group of non-professional rocketeers in this country who have launched well over one million rockets in five years with no rocket-caused injuries. These people are model rocketeers, and their activity is the art, sport, or hobby of studying, designing, constructing, and flying light weight, non-metallic, recoverable, and re-flyable rockets using commercially produced rocket engines, which do not require the handling, loading, or compounding of the propellant or other explosive materials by the user.

Model rocketeers have proven that rocketry can be safe, educational, and enjoyable. They have used their sport in science fair projects, classrooms, and full-scale laboratory research with notable success. They have formed clubs, held model rocket contests, have developed a complete competition program now internationally recognized, and have kept themselves alive and whole while doing it. Advanced modelers gain considerable knowledge of aerodynamics, physics, mathematics, meteorology, electronics, optics, photography, etc. How great, then, is the difference between model rocketry and other forms of non-professional rocketry, and why does this difference exist?

### Bomber Injuries

In early 1962, Estes Industries conducted a survey among its customers. Of 10,000 questionnaires mailed out to rocket enthusiasts, 1379 were returned. Among the questions asked in the survey was: "Have you or any of your friends or acquaintances been injured making or flying rockets which require you to make your own propellants?" Of the 1379 returning questionnaires, 63 did not answer the question at all, 1098 answered "no," and 218 replied "yes." The "yes" answers were given by 19.9 percent of those replying to the question.

One hundred twenty of those indicating accidents answered "yes" and gave little or no detail on the accidents. However, 98 gave details of the accidents. Of these, the 20 examples below are typical of the types of accidents which occur when home-compounded propellants are used.

"A friend of mine was testing his home made solid fuel by burying it in a mound of dirt, with a hole in the side of the mound for the fuse. He ignited the fuse, and ran for cover; but when it didn't seem to ignite he went back and peered into the hole. At that exact second the fuel ignited, the hot gases and flame striking his face and neck. He received 2nd degree burns and very unpleasant blistering. It took the complete vacation for the burns to heal. He's now using N.A.R. approved engines."

"A friend was injured while mixing a rocket propellant in his basement. He suffered 1st, 2nd, and 3rd degree burns on his face and hands."

"...I was making a fuel of zinc dust, sulfur, and potassium chlorate, when I finished putting the mixture in a jar and was about to put it up and call it quits for the night, I dropped it. When it struck the floor it blew up and I burned my hand badly and got several cuts from the glass, not to mention the mess it made of my chemistry laboratory."

"My friend was burned badly while firing a steel-tube rocket with sulfur and gunpowder for fuel. He is now trying to build a liquid-fueled rocket. I have tried to tell him to stop or he will be hurt. He says it is safe, but I know what will happen sooner or later: Boom!"

The above are minor injuries, and did not cripple or maim. Following are some examples of the more serious injuries, which seem to occur more often:

"Boy down the street blew his hand off while packing zinc and sulfur."

"Friend blinded in one eye using zinc and sulfur."

"Friend blew off three fingers, burned himself, and blew up lab in school. Now in hospital."

"Rocket blew up, friend lost an eye."

"I lost a finger in an explosion."

"Two weeks ago a friend of mine lost an eye and badly burned his right hand. He was loading a CO<sub>2</sub> cartridge with a zinc-sulfur mixture."

"Friend blew off hand."

"He' and some of his buddies were making rockets out of pipes filled with match heads. The pipe blew up and almost blew his stomach and intestines out! Thanks to the wonderful surgeons here, he was saved, but had to spend almost 1/2 year out of school."

"One was hurt and fingers blown off using an iron pipe stuffed with match heads, another hurt using a black powder rocket, still another hurt with facial injuries when trying to pre-heat a CO<sub>2</sub> cartridge."

"One boy had left arm amputated."

"Friend lost three fingers on one hand and suffered severe cuts all over. He was using match heads in an empty CO<sub>2</sub> cartridge."

"A boy I know lost a finger while tamping match heads into a CO<sub>2</sub> cartridge."

Even more serious are the following examples:

"Friend made his own propellant and it blew up. He died."

"Friend of mine was involved in an accident, where a boy had the rocket hit him at take-off, and ripped the side of his face off, killing him."

"A boy got killed 3 weeks ago in St. John, Ind., 2 miles from my house."

The above mishaps are far from all that occur. In a recent three month period this writer received copies of newspaper articles telling of two deaths in California and one in Arizona, as well as other less serious mishaps too numerous to mention.

### Model Rocket Mishaps

Also included in the above survey was the question "Have you or any of your friends been injured using our products (model rocket products)?" Of the 1379 returning their questionnaires, 34 failed to answer the question, 1343 indicated that they knew of no injuries, and two told of injuries. These two injuries were described as follows:

"Once I fired a rocket and it got stuck in a tree. A friend of mine tried to get it, but he fell and broke his arm!"



"My friend burnt himself with a piece of your nichrome wire. He held it with his finger while the battery was on."

Obviously, the above injuries are of an entirely different nature from those caused by home made propellants. Burning one's thumb with a hot wire is painful, but it is nowhere near as serious as the loss of an eye. To the date of this writing there has been only one recorded injury of any import which was directly caused by a model rocket product. This occurred when a twelve year old boy opened a model rocket engine, removed about one teaspoon of fuel from it, placed the fuel in a paper cup, and put a match to it. The boy was treated for burns on the face and hand.

The action of the boy involved was, of course, akin to drinking a pint of model airplane fuel to see what it tastes like, placing a finger into a live light socket to see what electricity feels like, etc. He was actually not a model rocketeer, since he not only violated all safety codes, but acted completely against the instructions supplied with each engine by the manufacturer. In spite of this accident, there is no indication that model rockets or model rocket engines when used according to established safety codes and according to the manufacturer's instructions present any appreciable hazard.

## The Dangers of Bombing

Accident rates for automobile travel, baseball, football, etc., are much higher than that of model rocketry. Automobiles alone injure 190 out of every 10,000 persons who use them each year, according to National Safety Council figures. On the other hand, the basement bombers have one of the highest accident rates in the nation. According to the American Rocket Society estimate, the accident rate for basement bombing is more than seven times as great as that for automobile travel.

What is there in the basement bomber's activities that makes them so dangerous? The basement bomber attempts to make rocket propellants with less than a professional knowledge of the field and with less than professional equipment. Rocket propellants must, by their very nature, contain explosive ingredients. If they did not, they would not have the energy to move a rocket.

A common claim among basement bombers is that they must work with propellants so that they will have a head start towards their careers as "rocket scientists." One wonders what application a "rocket scientist" would have for a pipe full of match heads other than to kill himself. The record indicates that experimentation with propellants is hard to reconcile with an attempt to learn, unless one feels that it requires an explosion to teach a person that rocket propellants can be dangerous. It is very obvious that little of value can be learned from the normal home made propellants such as micrograin, match heads, and nitrate-sugar mixture, since their performance is at best erratic. They are completely useless in the professional field. Amateurs credit micrograin with specific impulses ranging from 15 to 170. The burning rate for this material can range all the way from 14 inches per second to 290 inches per second. With characteristics such as these, it is obviously impossible to derive any reliable data from a rocket using this propellant.

Other home made propellants are often even more unreliable. Many make poor propellants but are highly dangerous explosives. The painstaking loading of a metal cylinder with match heads too often results in death or injury. Witness the case of the six year old boy who was watching his older brother make a "rocket motor" by ramming match heads through the narrow neck of an empty CO<sub>2</sub> cartridge. The "motor" exploded, hurling fragments of metal through the room. One piece struck the six year old on the neck, and he bled to death in thirty seconds.

Those who write books on amateur rocketry feel it necessary to include a section on first aid. A typical chapter covers chest wounds (what to do when the chest cavity is punctured), belly wounds (steps to take when organs are exposed), jaw wounds (how to keep the victim from suffocating on his own blood), head wounds (first aid for a skull fracture), as well as treatment for burns, simple and compound fractures, broken backs, broken necks, etc. If the above sounds morbid, it must be remembered that non-professional experimentation with propellants is a morbid thing. If one is to attempt to make his own propellants, he must be prepared for serious injury.

Remember that the person who builds and flies rockets with home made propellants has a one in seven chance of injury or death for each year he engages in such activities. For every six persons who finish the year uninjured, one will not be so fortunate.

There is no guarantee that because a group has adult supervision its activities will be any safer than those of the unsupervised basement bomber. An example is the 40 year old Texas high school chemistry teacher who thought that he would demonstrate a home made rocket engine. The toll: Seven students injured and the teacher dead.

## Why Take the Risk?

It would be unfair to declare that one form of non-professional rocketry is more educational than another, since the amount a person learns is completely dependent on the effort he puts into learning. However, there is ample proof that forms of rocketry employing heavy metallic rockets or the compounding and loading of propellants by the individual are inherently dangerous. On the other hand, there is equally substantial proof that model rocketry, as defined previously, is essentially safe.

To the person familiar with the history of model rocketry, it is not surprising that such a contrast exists. While other forms of rocketry "just grew," model rocketry was invented. From the beginning model rocketry was designed to provide an educational and safe form of non-professional rocketry. Model rocketry's success has been outstanding. It has shown itself in many cases to be effective in preventing basement bomber accidents by replacing a dangerous activity with a safe one. It has proven itself of educational value, as witnessed by its successful use in the classroom, in science fair projects, etc.

Some caution must be exercised by the individual in selecting his rocketry activities. There are some persons and groups who, either in ignorance or deliberately, try to pass off basement bomber activities as model rocketry. These people will often sell information and materials which, if used, would be highly dangerous. No activity which involves the home compounding and loading of propellants is actually model rocketry -- a home made engine is not a model rocket engine, but a home made engine.

## Preventing Accidents

Although more and more people are becoming familiar with the vast difference between model rocketry and other forms of non-professional rocketry, there still are some individuals who confuse the types of rocketry. Such persons should be corrected. A recognized safety code such as the N.A.R. Safety Code will give one of the best possible definitions of model rocketry.

While the records of manufacturers and sellers of model rocket supplies give a reasonably accurate reflection of the extent of the activity and provide a good basis for calculating participation in model rocketry, no such figures are available for the other forms of non-professional rocketry. It would be fair to estimate, however, that there are about as many people engaged in the hazardous forms of rocketry as there are in model rocketry. The rate of growth of model rocketry indicates, however, that it could virtually replace the various forms of basement bombing in a few years.

This, of course, will be possible only if model rocketeers continue to show the same safety-consciousness in the future that they have in the past, and if they continue to demonstrate that non-professional rocketry can be enjoyable, educational, and safe. Progress will also depend on the gaining of official recognition of model rocketry. Already the Air Force, the Federal Aviation Agency, the National Aeronautics Association, the Federation Aeronautique Internationale, and several other similar organizations have officially recognized and approved model rocketry, and still more can be expected to follow suit in the future.

While organized model rocketeers are working with groups like the National Aeronautics Association, there is much the individual modeler can and should do. As one who is aware of the dangers of non-model forms of rocketry, he should do all he can to keep his friends from injuring or killing themselves through experimentation with hazardous materials, and try to get them to confine their activities to safety-proven model rocketry. A word of caution is in order, though. Never tell a basement bomber that you can spit higher than his "rocket" will go. You probably can, but he is apt to take this as a challenge and ram more match heads into his pipe, or compress his micrograin even more, and the probable result will be serious injury to him and any unfortunate enough to be around him at the time of the explosion. Approach him instead through his common sense, and if he does not have any, stay well away when he does his experimenting.

Safety is common sense, and common sense contributes greatly to the enjoyment of a long, profitable life.



# MOONNIK-1

Design by  
Norman Foster  
Portland 1, Oregon

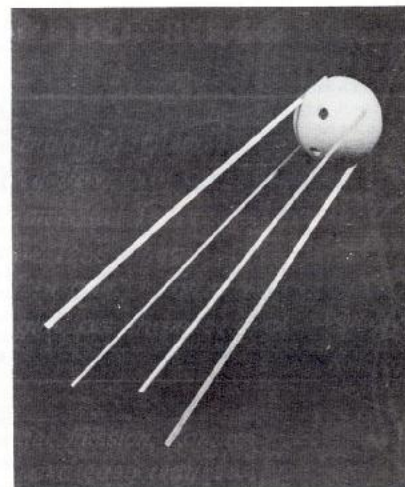
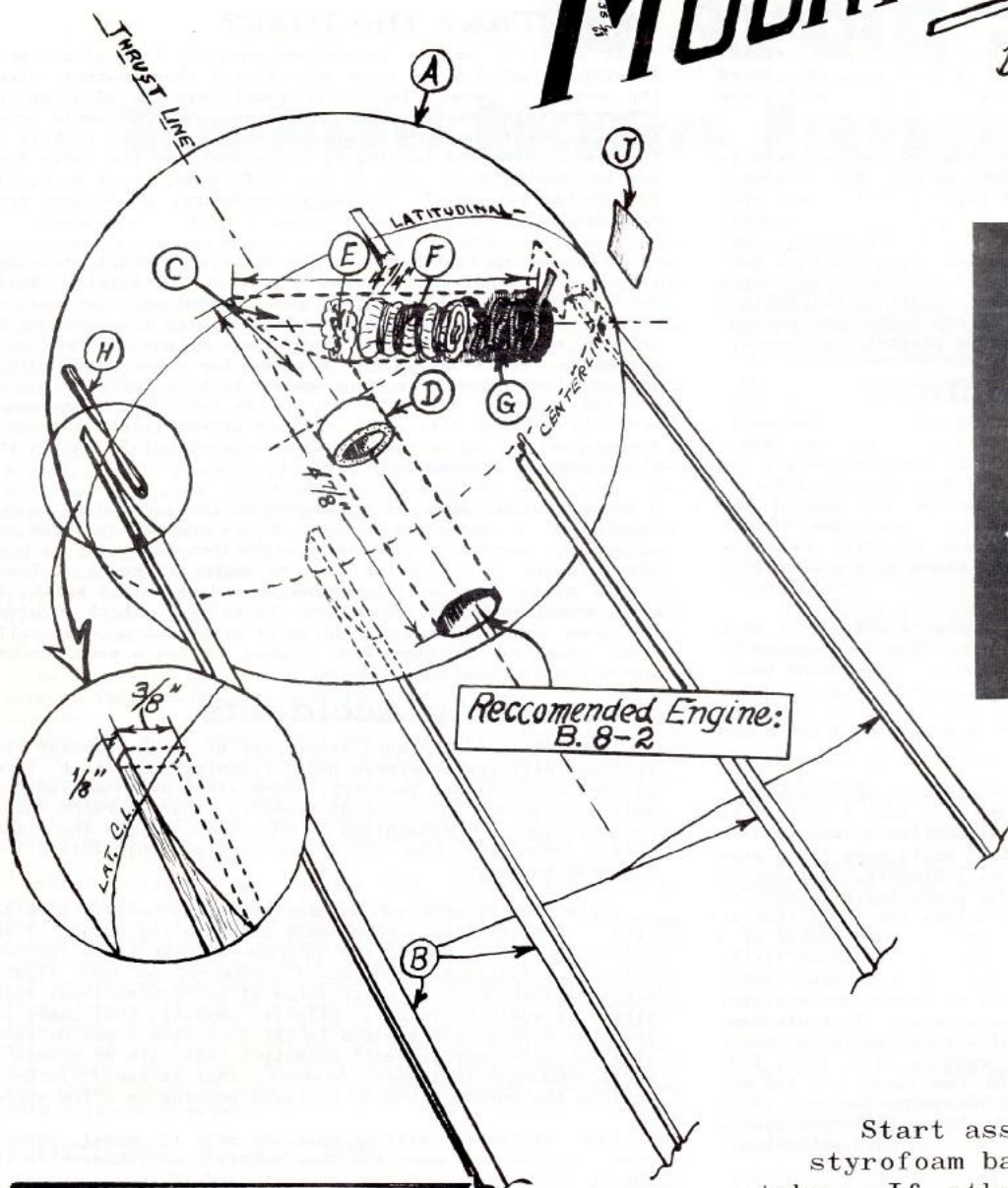

## Parts List.

- A. Styrofoam Ball 4-6" in diameter.
- B. 4 pieces balsa strip-  
3/8" X 1/8" X 24"
- C. 2 Pieces Body-tube  
(BT-30) 4 1/4" and 4 7/8"
- D. Engine Block (EB-30)
- E. Wadding
- F. Parachute (PM-2)
- G. Shock Cord (SC-1)
- H. Launch-Lug (LL1b)

Start assembly by drilling the styrofoam ball to receive the body tube. If other than a six inch ball is used the angle of the tubes will have to be changed. A smaller ball will improve the performance. The drilling may be done with a 3/4 inch dowel sharpened on one end. Next bevel the body tubes to meet at the required angle. Glue in place using white glue. Do not use other model cements as they may dissolve the styrofoam. Glue engine block in place by spreading glue in body tube with finger and pushing block in place with an engine casing. Glue on fins by cutting notches in the ball. Reinforce fins with glue-soaked tissue. Fasten shock cord with a patch of tissue over the end as at J. Attach parachute or streamer. A coat of spray enamel may be applied, but be cautious about using some paints as they may dissolve the styrofoam. The recommended engine is the B.8-2.



# Estes Industries Rocket Plan No. 15

## SPUTNIK - TOO!

AN ODDBALL...

Published as a service to its customers by Estes Industries, Inc., Box 227, Penrose, Colo. ©Estes Industries, 1964

Cut-a-way shows you where each part fits in and around the styrofoam ball.

Tape the template to the styrofoam ball placing a piece of tape near each of the four dowel positions. This will hold the template firmly as you press a pencil or other pointed tool through the center of each position marker (+) to clearly score the ball surface.

Drill a  $\frac{3}{8}$ " hole to  $2\frac{1}{2}$ " depth, centered on line of thrust. Now drill  $1/8$ " holes at angle that would cause all four dowels to meet at the line of thrust were they to emerge from the front of the ball. DRILL ONLY TO DEPTH OF  $1\frac{1}{2}$ ".

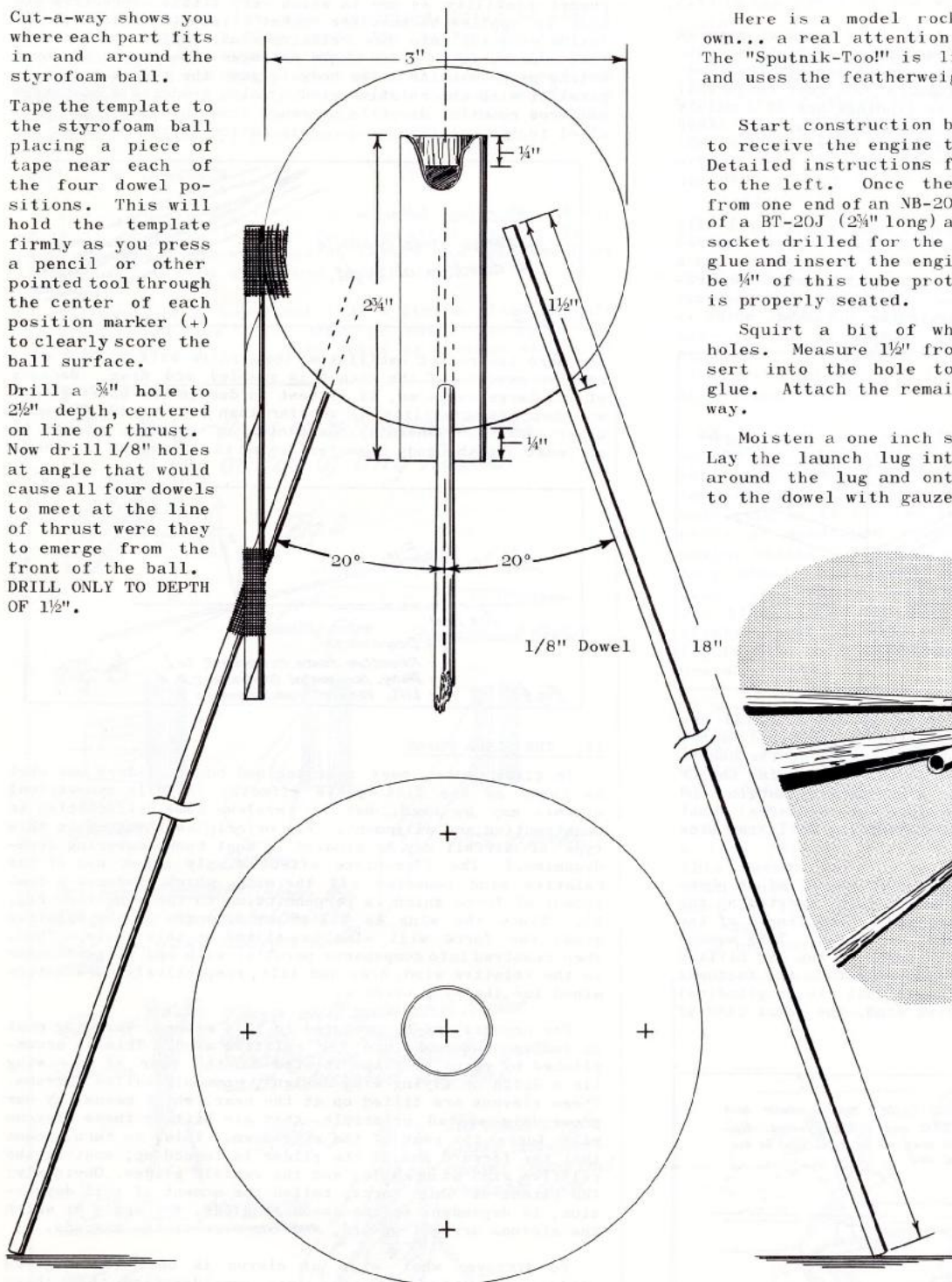

Here is a model rocket with a character all it's own... a real attention getter where ever it appears! The "Sputnik-Too!" is light in weight, easy to build and uses the featherweight recovery principle.

Start construction by preparing the styrofoam ball to receive the engine tube and dowel stabilizers. Detailed instructions for use of the template are seen to the left. Once the ball is ready, cut a  $\frac{1}{4}$ " slice from one end of an NB-20, glue this slice into one end of a BT-20J ( $2\frac{3}{4}$ " long) and stand aside to dry. Smear socket drilled for the engine tube with a film of white glue and insert the engine tube assembly. There should be  $\frac{1}{4}$ " of this tube protruding from the ball when tube is properly seated.

Squirt a bit of white glue into one of the  $1/8$ " holes. Measure  $1\frac{1}{2}$ " from one end of the dowel and insert into the hole to this point. Wipe off excess glue. Attach the remaining three dowels in this same way.

Moisten a one inch strip of gauze with white glue. Lay the launch lug into position and form the gauze around the lug and onto the ball. Secure the other to the dowel with gauze as shown.

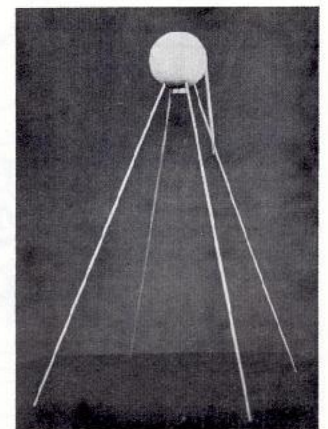
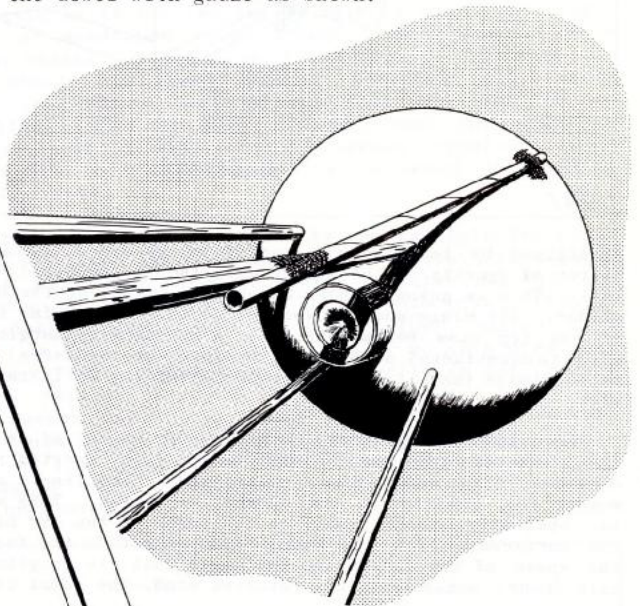

- 1 Styrofoam ball, 3" O.D.
- 4 Dowel, 18" x  $1/8$ " Dia.
- 1 Body tube  $2\frac{3}{4}$ " long
- 1 Nose block piece
- 1 Launching Lug, 5" long

- |        |        |
|--------|--------|
| Part # | SB-3   |
| " "    | WD-1   |
| " "    | BT-20J |
| " "    | NB-20  |
| " "    | LL-1C  |

NOTE: Rather than use the 5" launching lug, you may desire to mount a short lug on the ball and another lug on the dowel. If so, use another dowel to line them up.



# Estes Industries Technical Report TR-4

## Rear Engine Boost-Gliders

by Gordon Mandell

### INTRODUCTION:

These are the preliminary findings of a research program conducted since March of 1962. Some fifty boost-glide vehicles have been constructed to date, and to augment the findings library research in aerodynamics has been conducted. It must be borne in mind that these findings are of a mainly qualitative nature, with expected accuracy in most other cases (i.e.; quantitative findings) about plus or minus 10%, except as specified.

### I. THE BOOST PHASE:

A boost-glider is a model rocket which rises vertically in the manner of an ordinary fin-stabilized rocket, and returns in an aerodynamic glide. It is an aircraft and a rocket in one. Let us investigate, then, the design requirements for a vehicle of this type. The first thing we must bear in mind is that we are designing a rocket, which is

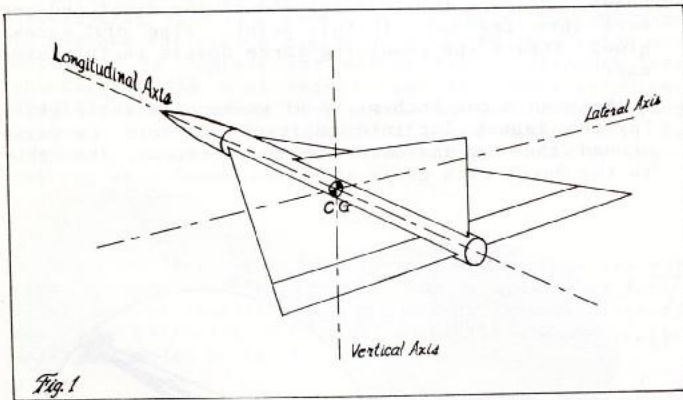

stabilized by locating the center of pressure behind the center of gravity in the manner detailed in Technical Report IR-1. This is going to have an obvious effect on the boost-glider: Its wings must be located so that they bring the CP of the top view behind the CG by a substantial margin, and also its directional stabilizing surface, the rudder(s), must be located so that it brings the CP behind the CG in the side view.

The distance between the CG and the CP is called in physics a moment-arm, and the stabilizing force exerted by the surfaces, wing and rudder, multiplied by the length of the moment arm, results in the corrective moment. This moment is, obviously, proportional to the force of the air hitting the surfaces, which, in turn, is dependent on two factors: The speed of the rocket and the angle that its longitudinal axis (body) makes with the relative wind. The ideal case of

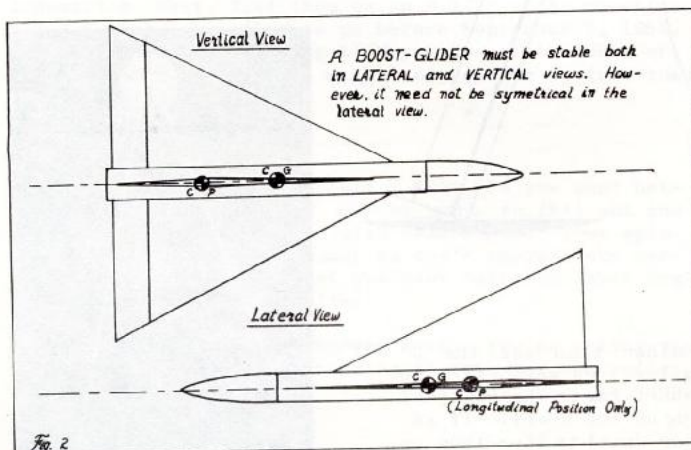

rocket stability is one in which very little corrective moment is applied because the rocket flies with little oscillation directly into the relative wind. While the air hitting the surfaces at an angle produces a component of force acting perpendicular to the body to push the rocket back into parallel with the relative wind, it also produces a component of force pointing directly rearward from the rocket, and parallel to the relative wind. This latter force is drag, and

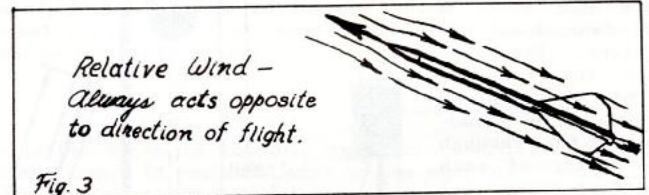

the more the rocket oscillates, the greater will be both corrective moment (if the rocket is stable) and drag. Because of its large surfaces, it is best to design the boost-glider so that its stability is greater than that needed for most other rockets. Generally the center of pressure should be at least 3/4 the body diameter behind the center of pressure.

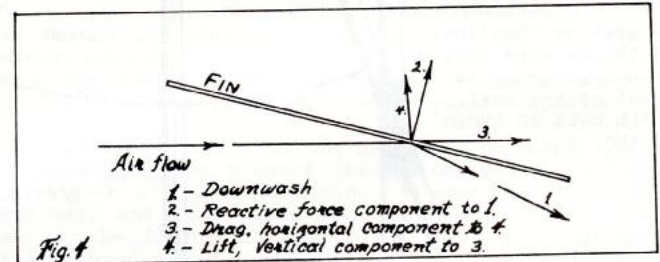

### II. THE GLIDE PHASE:

In glide phase, most rear engined boost-gliders use what is known as the flat-plate effect. (A fully symmetrical airfoil may be used, but it involves some difficulties in construction and alignment. The principles involved in this type of airfoil may be studied in most books covering aerodynamics.) The flat-plate effect simply makes use of the relative wind bouncing off the wing, which produces a component of force which is perpendicular to the wing (see Fig. 5). Since the wing is tilted at an angle to the relative wind, the force will also be tilted at this angle. Thus, when resolved into components parallel with and perpendicular to the relative wind, drag and lift, respectively, are determined for the wing surface.

For any lift to be produced in this manner, the wing must be inclined upward into the relative wind. This is accomplished by means of flaps located at the rear of the wing (in a delta or flying wing design), commonly called elevons. These elevons are tilted up at the rear, which means, by our previously stated principle, that air hitting these elevons will force the rear of the wing down. This, in turn, means that the forward end of the glider is forced up, meeting the relative wind at an angle, and the vehicle glides. Obviously, the extent of this force, called the moment of tail depression, is dependent on the speed of glide, the angle at which the elevons are set upward, and the size of the elevons.

To discover what size of elevon is best for a given glider, we must first take into consideration that there must be some force which makes the glider travel forward in the first place. In glide phase, the engine has been expended, and the only forces acting on the glider are those of air and gravity. After the rocket reaches flight apex and expels its engine, it begins to fall towards the earth. This produces a relative wind which is directly opposite to the direction of travel, i.e.; the rocket is falling down so the relative wind will be up (see Fig. 3). In almost every design imaginable, the CP will remain behind the CG after



ejection of the engine. As a matter of fact, many designs experience a forward shift of CG as the engine ejects. Thus, the glider remains stable as a rocket, and with its corrective moments still effective, the nose turns toward the ground. However, since the elevons have been actuated by this time, the rear of the rocket is forced down by the air acting against them, and thus the nose is forced up and the flat-plate effect suspends the vehicle in gliding flight. In order to glide, the rocket corrective moment must be overcome by the flat-plate effect of the elevons.

Since setting the elevons up at an angle also produces drag, the boost-glider will, in glide, reach a terminal velocity of forward motion and will then keep this velocity rather constant. So we now know that our elevons, to be effective, must produce a depressive force greater than the rocket's corrective force at the terminal velocity of glide.

With these factors in mind, then, we can see that the size of the elevons required depends on: (1) The distance between the CP and the CG of the top view in glide, and (2) the velocity of the vehicle in glide. The latter is itself dependent upon the size and the angle setting of the elevons, being from about five to fifteen miles per hour in the average glider. For a glider of approximately one half to one caliber rocket stability in glide phase, and which has elevons located at the rear of the wing at an average distance from the CG, elevons of approximately 20 to 30 percent of the total wing area are needed for a good, easily adjustable glide. This amount will vary down to about 10% for less stability in glide phase than in powered flight, and up to about 35% for greater stability in glide phase. Any glider requiring more than 35% is not properly designed, and probably possesses an engine located very far to the rear or excessive rocket stability.

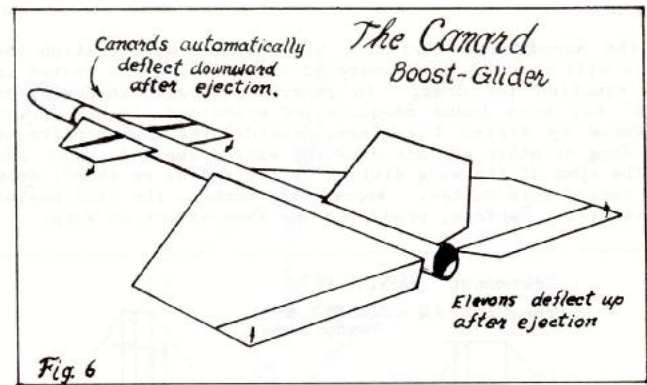

Fig. 6

There is no definite rule as to the best aspect ratio for delta or flying wing designs. It seems that high aspect ratio wings give faster response to thermal currents than low aspect ratio wings. Low aspect ratio wings are slower to recover from dives. However, structural considerations also come into the picture, as we shall see in Part III.

Just about any rudder large enough to give stability as a rocket in a side view is sufficient to directionally control the vehicle in glide. It has been noted, however, that a glider is more susceptible to spiral diving during turns when its center of directional guidance (the center of lateral area of the rudder) is more than 3/4 caliber behind the center of lift (the center of lateral area of the wing in flat-plate airfoil models). This has been found to be at least partially caused by a flow of air crosswise on the forward part of the wing, allowing excessive sideslip and turning, which results in a spinning, nose-down attitude.

A boost-glider will have better resistance to rolling in glide when its center of directional guidance lies above the CG, as when the rudder is located on top of the body tube. There are yet no definite rules for wing-tip rudders and for dihedral angle of lifting surfaces. However, it is known that dihedral angle in moderate amounts improves glide by giving a "pendulum effect" while it does not detract noticeably from rocket performance. The glider need not be symmetrical in side view, as are most rockets.

Another factor to be considered in designing boost-glid-ers is wing loading. This figure is widely used in professional engineering, and is arrived at by dividing the area of the lifting surfaces by the weight of the vehicle in glide condition (without engine). The higher the wing loading, the greater will be the rate at which the glider descends during glide. Obviously, then, one way to attain a good glide is to use wings as large as possible and body tubes as light as possible. However, this too is subject to structural limitations. Increases in lift may also be obtained by increasing the angle of attack to the relative wind. However, this also increases drag, and past a certain point drag slows the vehicle to the point where lift begins to decrease again.

### III. STRUCTURAL AND FLYING PRACTICE:

It would indeed be gratifying if we could use as high aspect ratios, as large surfaces, and as light construction as is dictated by ideal theory. Unfortunately, structural practice is controlled by the forces which a boost-glider must withstand in flight, and the dictates of these stresses often run opposite to those of theory.

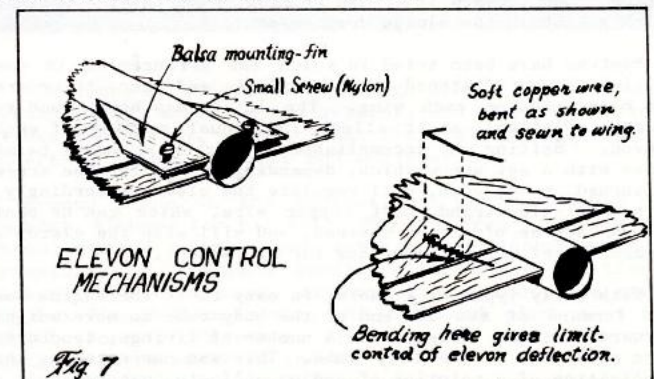

Fig. 7

The extent of these forces, caused by acceleration and air drag, is dependent upon the size of engine used and the number of engines or stages. The greater the acceleration and the duration of that acceleration, the greater the speed and hence the drag. In first considering the forces acting

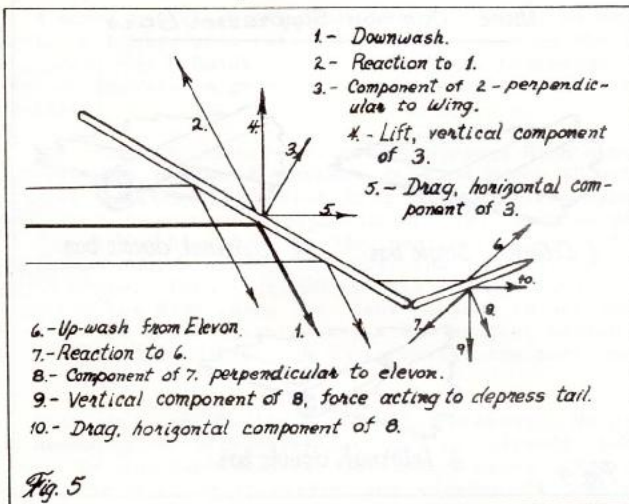

Fig. 5

An interesting variation on elevon-controlled gliders is the canard design. Canard gliders may be constructed in several ways. First, an explanation of "canard" might be in order. A canard is defined as any lateral stabilizing surface (that is, one that prevents pitching) located forward of the main lifting surface. Canards may also provide lift. When equipping canards with flaps, we must remember that, since the canards are forward of the CG, to induce the nose to angle upward we must deflect air downward by means of our canard-mounted elevons. Therefore, while we build rear-mounted elevons to flip upwards at engine ejection, we must construct canard flaps so that they flip downwards at this time. Construction of mechanisms for various types of flap actuation will be covered in Part III. One advantage of canard flaps is that, besides inducing an inclination to the relative wind of the main lifting surfaces, they also provide a small amount of lift themselves, since they deflect air downward and by the principle of action and reaction are acted upon by this air in an upward direction.

Designs which have only canard-mounted elevons usually are of rather high aspect ratio (the aspect ratio is the wing span divided by the average wing width, or chord) than other designs, and experience a slight rearward shift of CG after ejection. Since they have a longer moment-arm through which to act, canard flaps usually do not need to be as large as the flaps in other designs. Canard designs offer slightly more drag than others, and are all but useless when the nose is very heavy, since this shortens the moment-arm through which the flaps can act. Very successful canard designs have been constructed with elevons on both the main wing and on the canards, connected by thread to each other. However, these also suffer when the nose is heavy, and consequently must be built with very light noses.



on the aerodynamic surfaces, at constant acceleration the force will vary as the square of the velocity, as stated in the equation for drag. In general, a balsa thickness of 1/16" has been found adequate to withstand all air forces produced by Series I engines, provided the aspect ratio of the wing or other surface does not exceed about 4; that is, if the span of the wing divided by the width, or chord, does not exceed this number. Above this number, the wind begins to twist the surface, producing the same effect as warp.

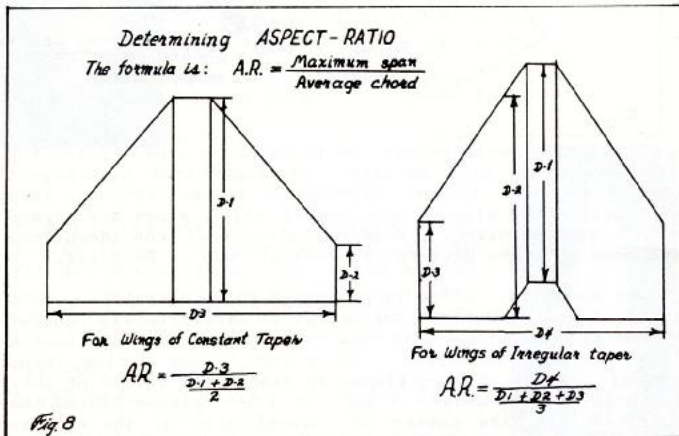

Also of importance is the effect of acceleration during boost. A one-ounce model's wings may weigh 23 times their normal weight for a short time during boost. For this reason, wings should be kept as light as possible consistent with adequate aerodynamic strength. Also, wings which have their CG closer to the body tube, or with low aspect ratios, will be more resistant to being torn loose from the body tube by acceleration forces.

The strongest wing-body joints are possible when the wings are joined together with each other and the body at the underside of the body and the connection reinforced by 1/2 inch wide strips running parallel to the body at the joint. The grain on these strips should be at a right angle to the grain of the wings. The wing-body joint may also be strengthened by the use of gauze or silk reinforcing, by using thicker balsa for the wings, and by using the longest practical wing-body joint.

Internally-operated elevon actuators, such as pistons driven by the ejection gases, have been tried, but have been found to be not as reliable and more difficult to construct than those actuated by the ejection of the engine. The simplest system to employ is one in which a piece of wire or balsa is held depressed by the engine casing.

When one end of the actuator is held in place by the engine, the other end of the stiff wire or balsa is attached to the elevon, so that the elevon is in neutral position with the casing in place. A piece of elastic thread is fastened to the elevons in a manner which will pull them up (or canard flaps down) when the engine leaves the body tube and allows the wire depressor bar to travel to the actuating position (see Fig. 9). When the depressor bar runs rearward from the elevon to the casing, it should be held down by the casing; when forward it should be held upward by the casing, which will push the elevon down to neutral.

Systems have been tried in which the arrangement is one continuous bar fastened to both wings, and where there are two bars, one for each wing. The latter has been found to be more practical, as it allows individual setting of each elevon. Setting is accomplished either by a small balsa brace with a set screw which, depending on how far the screw is turned up or down, will regulate the elevon accordingly, or by a single-strand, soft copper wire, which can be bent to the degree of elevon desired, and will stop the elevon's upward travel depending on how far it is bent.

With early types of gliders, in many cases the engine was set forward of the aft end of the body tube to move weight forward further. This, after a number of firings, tended to burn away some of the body tube. This was corrected by the application of a solution of sodium silicate (waterglass), a chemical used as a flameproof and egg preservative, to the inside rear of the body tube. Waterglass has the disadvantage of blistering and abating into the exhaust gases, leaving a flaky residue and unsightly appearance, as well as impairing the fit of the engine into its mountings. For applications involving the protection of elevons or rudders

from exhaust gases, aluminum foil was found much more satisfactory, the foil being glued to the surface in question.

An even better alternative involves the use of an expended engine casing to shift weight forward. The nozzle is drilled or chipped out of the old casing, and the casing is then glued or taped to the front of a live engine. Thus, when the engine is ejected, it will take the expended casing with it, lightening the nose for good glide. This method gives much greater boost stability. The current world's record holder of glide duration was equipped in this manner.

For the early recessed-engine models, and for multi-staging, it has been found necessary to arrange some system by which the depressor bars will not interfere with the stage joint. Obviously, a system using depressor bars which extend rear of the body tube to be operated by an engine which sticks out of the rear of the tube is impossible in recessed engine models, and interferes with mating of the stages. Instead, ports are cut in the body tube forward of the elevons, and the depressor bars are operated through these ports. This adds to drag and is more difficult than external-bar arrangements, but is the only proven method of meeting these special requirements. This method is also used to operate canard flaps, which are located far forward on the body.

Ports too near the front of the engine casing have caused ejection failure. In general, ports should not be cut less than about 3/4 inch to the rear of the point where the forward end of the engine casing will rest in flight. In this way, pressure does not escape from the ports at ejection charge activation.

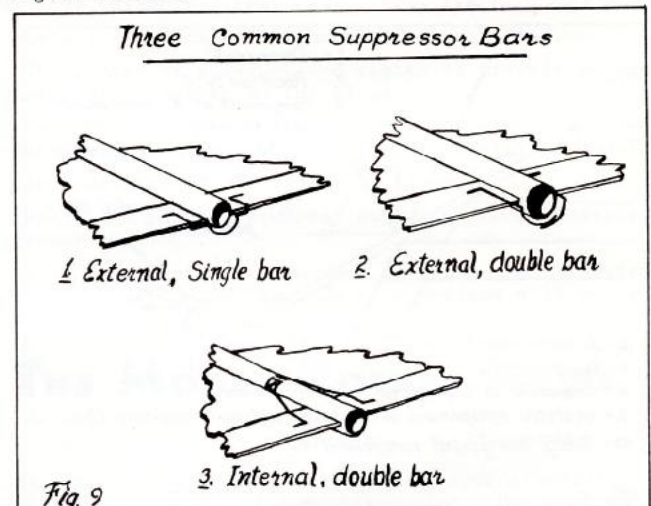

Elevons in the rear and canard flaps in the front can be operated together if the rear elevon actuator is made according to standard practice, and then strands of ordinary thread are attached to the elevons, as far to the rear as possible. The thread is then brought forward, crossed over the body tube, and attached to the canard flaps. Thus the left elevon will, when released, lower the right canard flap, and the right elevon the left canard flap. The canard flaps are, of course, equipped with elastic thread to pull them down when the thread is slackened, which happens when the rear elevons are actuated. Gliders using this system can be made to stay in the air for more than two minutes, single staged.

Research on cluster-engined boost-gliders has so far shown that they are not as practical to build and fly as single-engined gliders, due to the large concentration of weight at the rear of the body. This requires that rocket stability be increased by placing the wings very far to the rear, with the result that the CG moves forward a considerable distance at the ejection of the engines. This in turn makes extremely large elevons a necessity.

#### CONCLUSION:

The design and construction of good boost-gliders is still an art, and requires a high degree of skill in the modeler. But there are few things in any area of modeling which can compare with the satisfaction of building and flying a good glider. This is a field with a genuine challenge for the builder, and those who accept the challenge will find themselves plunged into a search for new methods, materials, and principles that results not only in a greatly expanded knowledge of the physics of flight, but also in contributions to the entire art of model rocketry.