

MODEL ROCKET NEWS

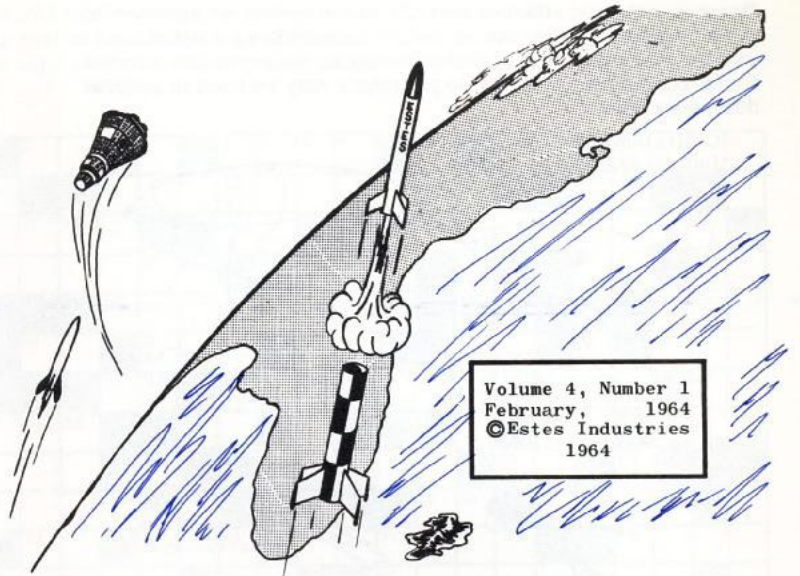

Bring 'em Back - - Gently!

PARACHUTE RECOVERY

The parachute offers one of the simplest, most effective recovery methods available to the model rocketeer. At the same time it is often misunderstood, misapplied and mistreated. Experience has shown that the principles and methods described here are reliable with both single and multi-stage rockets provided the model itself is built correctly.

PARACHUTE MATERIALS

While practically everything from bed sheets to balsa has been tried for making parachutes, three materials, paper, silk and plastic, dominate the field. Paper is inexpensive but not durable, so it is of limited value for model rocketry. Paper parachutes rip easily when hit by high velocity air and do not unfurl as rapidly or reliably as plastic or silk when packed in small diameter body tubes.

Silk is an excellent material for model rocket parachutes, but combines disadvantages with its good points. While it is light, will not take a "set" easily and is extremely strong, it is also expensive and a difficult material to handle in construction. Loose silk threads have a habit of tangling and preventing the parachute from opening, so it is necessary to sew all edges of the fabric into tight seams to get proper operation. Shroud lines should be sewed directly to the silk.

The most widely used parachute material for model rockets is plastic. Combining the virtues of low cost, durability and versatility, it is available in an almost unlimited range of colors, thicknesses and sizes. The types of plastic used for parachutes are for the most part those sold especially for model rocket use and the plastic bags used by cleaners to protect clothing. Plastic thickness generally ranges from .0015" to .0005". For normal use .00075" is the minimum recommended thickness. The main disadvantage of plastic is its sensitivity to heat. The parachute must be well protected from the ejection charge.

Shroud lines are important to the operation of any parachute. Experience has shown that smooth, hard surface material such as carpet thread is best. Shroud line length should be sufficient to allow the parachute to open fully. Generally the proper length will be between 3/4 and 1 parachute diameter (for example, between 9 and 12 inches for a 12 inch diameter parachute).

PARACHUTE SHAPE

The most common parachute shapes are square, round, hexagonal and octagonal. While square parachutes are the easiest to make, they are not very efficient and allow a considerable amount of sway during descent. Round parachutes are fairly stable in descent, but are more difficult to make. The hexagonal and octagonal parachutes are highly stable, reasonably easy to make and generally give the best appearance. The accompanying drawings illustrate methods for making these shapes.

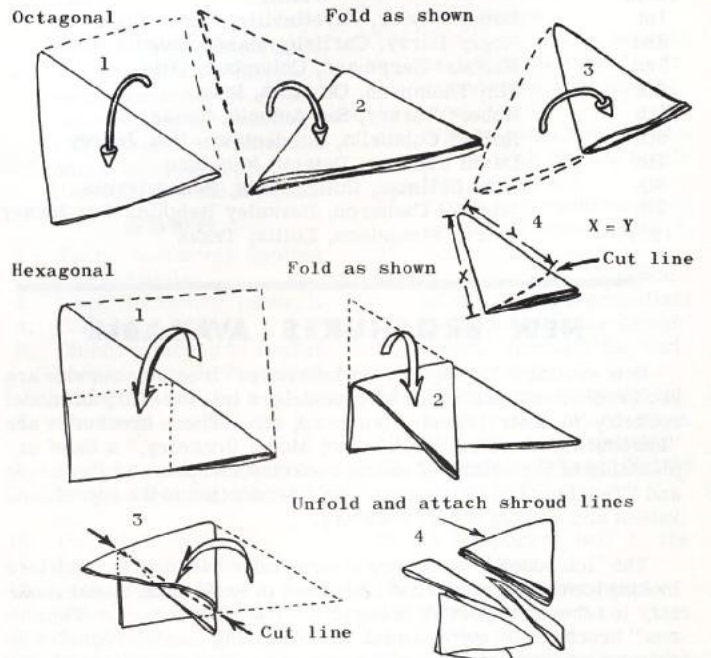

PARACHUTE ASSEMBLY

After cutting the parachute to shape as in the preceding section shroud lines are attached either by tying or by using tape discs or strips. Tape strips are generally the most satisfactory since they are easy to use, light and strong. When shroud lines have been attached to the parachute and cut to the proper length

they can either be attached directly to the rocket or attached to a snap swivel. (The use of a snap swivel offers a definite advantage since different parachutes may be selected for various flying conditions or the same parachute may be used in several different rockets.)

Locate shroud line positions for round, 6 line 'chute

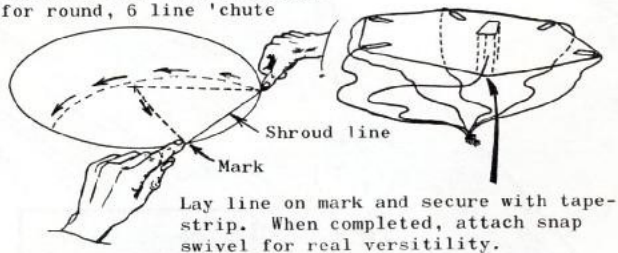

Tying to snap swivel

Pass lines through eye...

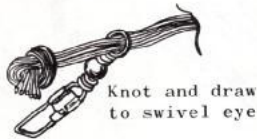

Knot and draw to swivel eye

Cont'd Page 5

CONTEST WINNERS!

DESIGN CONTEST ...

Place	Winner	Rocket
1st	Merrell Lane, Niagara Falls, N. Y.	Loadlifter 1A
2nd	Ronnie Randolph, Taft, Texas	X-12
3rd	Howard Rotz, Floral Park, N. Y.	The Duo
4th	Mike Dorffler, Hastings, Nebraska	Rodini
5th	Greg Ulve, Hawthorne, California	California Ray
	Charles Walker, Bedford, Indiana	Sorcerer A
	Jeff Smith, Essex Fells, New Jersey	The Spook
	Herbert Herrmann, Columbus, Ohio	Star Duster
	Wade Lucas, Barberton, Ohio	H.A.E.C.-IV

IDEA BOX ...

Place	Winner
1st	Danny Taylor, Fayetteville, North Carolina
2nd	Roger Berry, Carlisle, Massachusetts
3rd	Herbert Herrmann, Columbus, Ohio
4th	Jim Thompson, Ottumwa, Iowa
5th	Robert Burney, San Antonio, Texas
6th	Robert Colabella, Bordentown, New Jersey
7th	David Chasney, Detroit, Michigan
8th	Alan Hallman, Collegeville, Pennsylvania
9th	Michael Cameron, Berkeley Heights, New Jersey
10th	Fairis Samuelson, Lolita, Texas

NEW BROCHURES AVAILABLE

Now available through Estes Industries' free plan service are two brochures designed to help modelers tell the story of model rocketry to their friends, teachers, etc. These brochures are "Introducing the New Horizons of Model Rocketry," a brief explanation of the nature of model rocketry and some of its values and "Teaching for Tomorrow," an introduction to the educational values and uses of model rocketry.

The "Introducing" brochure is especially valuable to modelers looking for new members for clubs and in explaining model rocketry to other prospective hobbyists. The "Teaching for Tomorrow" brochure is quite useful in explaining model rocketry to science teachers and educators as well as other education-minded persons.

Sample copies of these brochures are available on the same basis as plans and other materials on the Customer Service section of the Clip 'N' Mail Page (see the inside of this issue's wrapper). The brochures will be sent free of charge to all who mail in the coupon with the appropriate squares checked and enclose a stamped, self-addressed envelope with their request.

NOW... MULTI-STAGE DESIGN CONTEST

Take a long look at the list of goodies that go to the winners of this contest and then sit down and build the perfect multi-stage model. Then when you're through testing the rocket, send the plans, parts list and instructions to: Multi-Stage Contest, Box 227, Penrose, Colorado, 81240.

- 1st Prize--\$50 in merchandise credit.
- 2nd Prize--\$25 in merchandise credit.
- 3rd Prize--\$10 in merchandise credit.
- 4th Prize--\$5 in merchandise credit.
- 5th through 10th Prizes--Astron Drifter kits.

CONTEST RULES

- 1) All plans must be drawn to scale. Pencil or ink drawings are acceptable.
- 2) A parts list must accompany each entry.
- 3) Each entry must be flight tested to assure that it has suitable flying characteristics.
- 4) Only multi-stage designs will be qualified.
- 5) The center of gravity for the complete rocket and each individual stage must be marked on the plan.
- 6) Sufficient information must accompany the entry to allow judges to build an exact duplicate of the original model.
- 7) Employees of Estes Industries and members of their immediate families are not eligible to enter this contest.
- 8) The decision of the judges is final.
- 9) Entries must be postmarked no later than midnight, May 31, 1964.
- 10) All designs submitted become the property of Estes Industries, Inc. No plans or designs will be returned.



MODEL ROCKET NEWS

The Model Rocket News is published four times annually by Estes Industries, Inc., Penrose, Colorado. It is distributed free of charge to all the company's mail order customers from whom a substantial order has been received within a period of one year. The Model Rocket News is distributed for the purpose of advertising and promoting a safe form of youth rocketry and for informing customers of new products and services available from Estes Industries. Rocketeers can contribute in several ways towards the publication of the Model Rocket News:

- (1) Write to Estes Industries concerning things you and your club are doing in this field which might be of interest to others.
- (2) Continue to support the company's development program by purchasing rocket supplies from Estes Industries, as it is only through this support that free services such as the Model Rocket News, rocket plans, etc., can be made available. This support also enables the company to develop new rocket kits, engines, etc.
- (3) Write to the company about their products and tell what you like, what you don't like, new ideas, suggestions, etc. Every letter will be read carefully, and every effort will be made to give a prompt, personal reply.
- (4) Participate in the Writer's Program (described in Vol. 2, No. 3 of this publication). Not every article submitted will be accepted, but through trying skill is gained and those which are accepted contribute greatly to other persons' enjoyment of model rocketry.

Vernon Estes
Publisher

William Simon
Editor

(NOTE: This is the first issue of the Model Rocket News to be published since the August/September 1963 issue. Publication schedules for Catalog 641 and the new kit instructions did not allow us to work on the MRN.)

(This crossword puzzle is a Writer's Program entry by Larry Arnold of Carlisle, Pennsylvania. We feel that it is a real challenge to develop a puzzle such as this, and solving it should be an excellent test of your knowledge of rocketry. The solution will be printed in the next issue of the MRN, but if you're very impatient, you can get a copy of the solution through the Customer Service section of the Clip 'N' Mail Page. See this issue's wrapper for more information.)

Across

- 2. Magnesium, chemical symbol.
- 4. Method of attaching lead wires to nichrome.
- 9. Total impulse (abbr.).
- 10. Term which can be given to a rocket vehicle traveling in space.
- 12. Object over which the launching lug is placed.
- 15. Ducted _____, a system in which thrust is produced by drawing in air and accelerating it through a duct by the exhaust gases of the engine.
- 17. _____ propellant, a rocket propellant consisting of two unmixed or uncombined chemicals (fuel and oxidizer) fed to the combustion chamber separately.
- 18. _____ Bullet, a rocket which uses the tumbling recovery device.
- 21. Decigram (abbr.).
- 22. _____ Number, a dimensionless ratio used to predict changes in the flow characteristics or air about an aerodynamic surface.
- 24. Rocket cargoes.
- 27. International Meteorological Organization (abbr.).
- 30. A-____, a term designating perfect function.
- 31. Touch Down (abbr.).
- 33. Extension at right angles (abbr.).
- 34. The effect in which thrust is lost through recessing an engine forward in the body tube.
- 36. Technical Report (abbr.).
- 38. Metallic rock.
- 39. Lines (abbr.).
- 40. Number used to determine the circumference of a circle; 3.14159.
- 41. An insect which makes a good payload passenger.
- 42. Height (abbr.).
- 43. _____-1, a liquid rocket propellant fuel, similar to kerosene.
- 44. A snakelike fish.
- 45. Ending usually found on adverbs.
- 46. Boost-glider (abbr.).
- 47. Average (abbr.).
- 48. The area in which the propellant of a rocket is burnt.
- 50. Antiaircraft (abbr.).
- 51. Continuous Wave Oscillator (abbr.).
- 54. The point on a rocket about which all its weight is evenly distributed (abbr.).
- 55. Launching Ramp (abbr.).
- 56. _____ bolt, air-launched ballistic missile, canceled in December 1962 by the Secretary of Defense.
- 57. The point of the celestial sphere directly opposite the zenith.
- 58. Letter often used to designate a guided missile as experimental.
- 59. The control surface on a single-wing boost-glider.
- 62. To carry out.

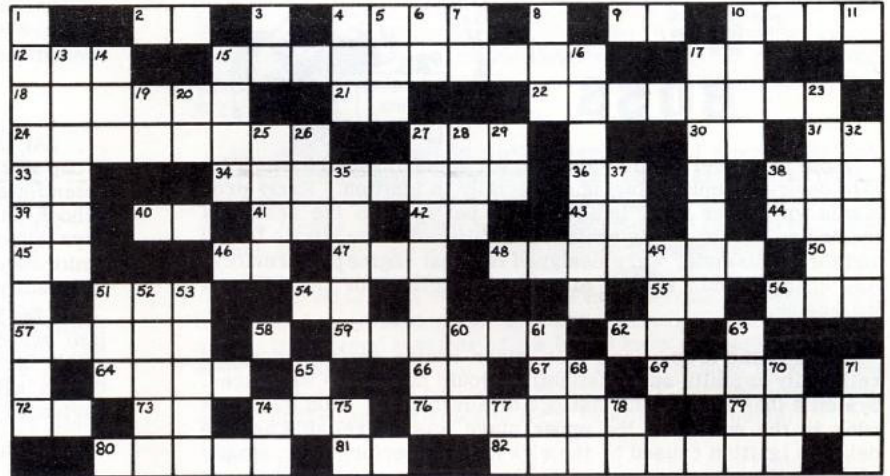

- 64. The heavenly spheres.
- 66. Chemical symbol for sodium.
- 67. Amplitude Modulation (abbr.).
- 69. Animal fiber which could be used for protecting a 'chute from the ejection charge.
- 72. Shock cord (abbr.).
- 73. Estes Industries (abbr.).
- 74. Minute (abbr.).
- 76. The propulsive force developed by a rocket engine, caused by rearward expulsion of gases.
- 79. The wire which runs from the launcher to the firing panel.
- 80. Leader in model rocketry.
- 81. Reentry Vehicle (abbr.).
- 82. The position or orientation of a spacecraft as determined by the relationship between its axes and some reference plane or line such as the horizon.
- 19. New Line (abbr.).
- 20. Command which means "begin."
- 23. Featherweight recovery model.
- 25. Aerodynamic forces acting to slow a rocket in flight.
- 26. Body that supplies power for the transmitter in the Vanguard I satellite.
- 27. _____ stability, the property that causes a rocket, when disturbed, to return to its normal attitude of flight without the action of any mechanical device.
- 28. Engineering school.
- 29. _____ tagonal, common parachute shape.
- 32. The time period between engine burnout and activation of the recovery device.
- 35. A propulsion section of a rocket with its own auxiliary equipment.
- 37. Common measurement of rotational speed (abbr.).
- 38. Old English (abbr.).
- 49. _____ through, the rupture of the forward propellant wall in a booster engine.
- 51. Chem. formula for cadmium oxide.
- 52. Objects which connect the battery and micro-clips.
- 53. The path of a satellite.
- 60. Vehicle's Average Height (abbr.).
- 61. Astro_____.
- 63. A temporary halt in the countdown.
- 65. Prefix meaning twice.
- 68. Mountain Standard Time (abbr.).
- 70. Side sheltered from the wind.
- 71. Electronic Data Processing (abbr.).
- 74. Margin of Safety (abbr.).
- 75. Noise Ratio (abbr.).
- 77. Chemical symbol for radium.
- 78. Titanium (chem. symbol).

New Products

Rocket Flight Data Sheet

A truly universal data sheet for model rocketeers, each sheet has spaces for complete data on four flights of a model. Includes the following sections: Preflight, Countdown Checklist, Launch, Weather, Flight Data. The perfect record for the serious model rocketeer. Each sheet measures 8-1/2 x 11 inches, printed on both sides. Shipping weight 2 ounces.



Cat. No. 641-DS-1 5 for \$20

Astron Drifter

Spectacular for its upward flight and recovery, the Astron Drifter is designed for parachute duration competition; combines low weight with large 'chute capacity. Perfect for contests, the Astron Drifter comes complete with a 12" 'chute for testing and sport flying and a 24" 'chute for snagging thermals and really staying up there. Parachutes are easily interchangeable. Recommended engines are 1/2A. 8-2, A. 8-3, B. 8-2 and B. 8-4. In easy to assemble kit form. Shipping weight 8 oz.

Cat. No. 641-K-14 \$1.75 each

Down

- 1. Term commonly applied to solid fuels.
- 3. Dead Reckoning (abbr.).
- 4. Compound (abbr.).
- 5. Object attached to rocket body to guide first part of model's flight.
- 6. Chemical symbol for illinium.
- 7. Payload section (abbr.).
- 8. Prep. meaning "in place of."
- 10. Parachute material.
- 11. Post Script (abbr.).
- 13. Spoken out loud.
- 14. Twenty-four hours.
- 15. The highest point in the flight of a rocket.
- 16. _____ point, the point on an imaginary line joining two celestial bodies where their gravitational fields exactly balance.
- 17. A rocket engine used to impart added velocity to a sustainer stage.

NOTES FROM THE BOSS

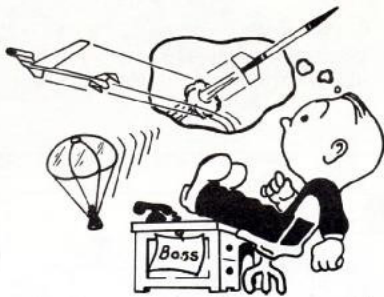

Most rocketeers are aware that for some time there was a lot to be desired in multi-staging, especially in ignition. Early problems with upper stage ignition came partly from the design of the engine nozzle. This could not be altered since nozzle length and throat diameter were designed for best engine performance. Any change would reduce either the efficiency or reliability of the engine.

At one time it appeared that either engine performance and reliability or multi-stage reliability would have to be sacrificed. Systems then in use had distinct disadvantages: Placing Jetex wick in the nozzle of the upper stage was not reliable and the delay in ignition caused by the wick lowered performance; simply sticking the upper stage over the lower stage was even less reliable except with Series II engines in the upper stages. Unfortunately, Series II engines are not suited for the more sophisticated altitude probes. Although many spectacular and successful flights were made, many rocketeers kept from flying more than one stage because of the possibility of failure.

The problem actually boiled down to inducing the blow-through gases from the booster to travel forward through the nozzle of the upper stage engine to the propellant grain. How this problem was solved is described in the new TR-2 beginning on page 9.

With multi-staging finally in a practical state, it's only appropriate that we hold a new multi-stage design contest. There are many areas of multi-staging still to be explored, including booster recovery, upper and lower stage efficiency, aerodynamics and stability. When you design and build your entry take the time to apply some imagination and produce a model that is more than just a set of fins and a body. Not only will you stand a better chance of winning, but you'll also gain valuable experience.

As far as coupling and ignition are concerned, models using the obsolete systems stand little or no chance of winning. Your best bet will be to either use the systems described in the new TR-2 or develop your own. Don't send in your entry until you're satisfied that you've licked all the bugs in the design and it has flown perfectly at least once.

One other thing--don't ruin your chances of winning by failing to follow the contest rules (page 2). Read the rules before you send in your entry.

Some of you fellows have been giving yourselves and us a hard time by failing to specify which color you want on parachutes, paint, dope and decals--or voltage on Astro-Launches. Since our mind-reading machine broke down some time ago, we can't send you what you want unless you tell us what to send on the order blank.

Looking for a science fair project? You might think about doing one on the difference in performance obtained with three engines in a cluster (single stage) and three engines in series (three stage) when the initial weight of the rockets is the same. You may be surprised at how big the difference is.

As if we didn't have enough problems with Cuba, South Vietnam, Zanzibar and cigarette smoking, now Jetex wick is no longer available. Things were bad enough when it would dry out and fizzle at just the wrong time. The best information we have been able to obtain is that Jetex will no longer be shipped into this country, but we'll let you know right away if it becomes available again. Until then we'll just have to do without.

We've added a 24" parachute and two micro-clips to the Range Kit Special to replace the Jetex wick which can't be shipped. The catalog number has been changed to RBK-1A, and we'd sure appreciate it if you'd make these changes in your catalog.



Letter Section



... I wish to claim a record for launching a MRN to 1,100 feet in an Astron Ranger with three B. 8-4's. It took off like a big bird and made a perfect separation at the peak. Both 'chutes opened and settled down about 1/2 mile from the launcher.

Pat Artis
Ironton, Ohio

... At this writing I am in the process of organizing a small group that is interested in your products. This group, The Young Scientist's Club, is one of the organizations on the campus of my school, Campbell Senior High. We meet on Tuesdays and Thursdays during the school year. This group consists of sophomores, juniors and seniors. I have high hopes for this group because it is steadily increasing in size.

At the last meeting of the club we decided to divide the group into two competitive sections, each section with its own chairman. Because the club is set up on a competitive basis, I feel that it will be an open invitation for others who have never experienced the thrill of launching a rocket of their own making.

Neill Crosslin, Jr.
Daytona Beach, Fla.

... I have a question about the engine selection chart in your 1964 catalog. . . why should the 1/4A. 8-0 be able to lift more weight than the A. 8-0 or B. 8-0 engines?

Michael Bertin
Amherst, Mass.

Although it would appear that the A or B (Series I) engines should be able to lift more weight than the 1/4A booster engines since the larger engines have more total power, effective performance of model rockets depends more on efficient use of power than on large amounts of power. In this case the 1/4A booster has a higher average thrust than the other Series I engines. As you can see from fig. 1, using a 1/4A booster gives us a higher average thrust during the first part of the flight than if we were to use some other engine.

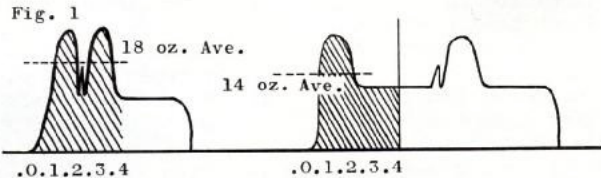

A high average thrust means high average acceleration--the rocket is moving faster sooner. Fig. 2 shows how a rocket will reach any speed sooner when it is accelerated with a larger number of G forces. (To determine the G forces at which the rocket will accelerate, divide the average thrust of the engine by the total weight of the rocket, including engines, and then subtract 1 from the quotient for the constant pull of gravity.)

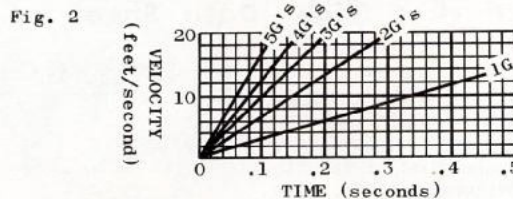

In fig. 3 the relation of rocket speed to wind speed and the resulting tendency to weathercock are shown. The faster the rocket travels the less it will weathercock, giving a straighter and higher flight. A large part of the altitude a rocket could reach is lost when it weathercocks. As the rocket tilts further into the wind it loses more altitude. Of course for those big birds the best solution is to use a Series II booster (B3-0) in the bottom stage for the straightest, highest possible flight.

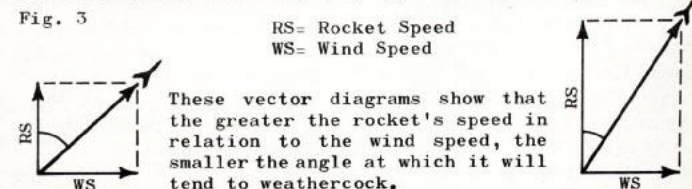

The parachute is ejected from the rocket body in flight with considerable force and generally opens quite suddenly. This shock must be absorbed so shroud lines, etc. are not broken. A length of shock cord (model airplane contest rubber) is connected between the parachute and the main part of the rocket. The shock cord is attached to the rocket body by cutting two slits,

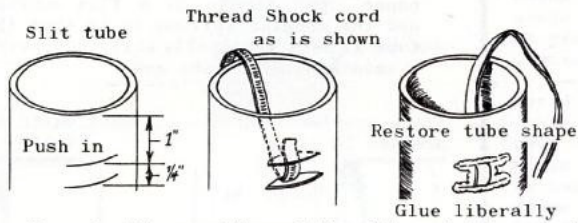

passing the end of the cord through the slits and gluing as shown in the drawing. The free end of the shock cord is then attached to a screw eye in the base of the nose cone. The parachute can then be attached directly to the nose cone if the cone weighs less than 1/2 ounce. If the nose cone weighs more than 1/2 ounce there should also be a length of shock cord between it and the parachute.

PARACHUTE PACKING

When preparing a rocket for flight it is extremely important to protect the parachute from the heat of the ejection charge. The most reliable and effective way of doing this is by filling the body tube for a distance equal to 1-1/2 times its diameter with flameproof tissue, cotton or recovery wadding. The wadding serves as an insulating layer between the parachute and the engine and as a gas seal and piston to insure that the ejection charge works evenly against the parachute and nose cone.

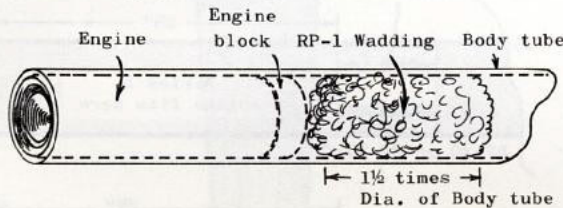

When the wadding has been placed in the tube, dust the parachute lightly with talcum powder to keep it from sticking to itself when packed in the rocket body. Next form the parachute into a spike shape as shown, fold once or twice to make it fit the space available in the body tube and insert it into the tube. Pack the shroud lines and shock cord in over the parachute and push the nose cone or payload section into place.

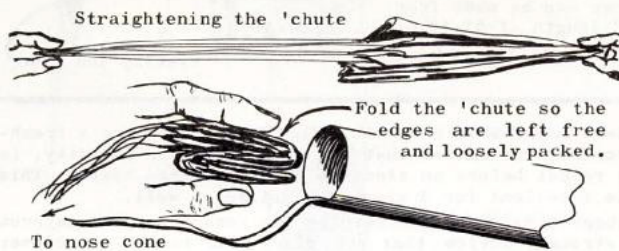

It is interesting to note that elaborate, precise and exacting methods for folding model rocket parachutes have been proposed and used, but the most reliable recovery comes with the somewhat sloppy system described above. Current theory holds that this reliability is the result of the tendency of the material to spring back somewhat when crumpled and the ability of loose corners, edges and folds to catch the breeze.

For parachute duration contests special attention to packing, secure shroud line attachment, etc. is important. The rocket's body tube should be large enough to hold the parachute and wadding without squeezing and yet small enough to keep the rocket's weight as low as possible. B. 8-2 and B. 8-4 engines are generally recommended for use in duration events.

For best results a parachute should have at least 38 square inches of area for each ounce of rocket weight. Thus the maximum weight for a 12 inch parachute will be about 3 ounces. Less area may be used on very light rockets, since they will gain less momentum than larger models. On the other hand the upper limit on parachute area can be determined only by considering desired duration, landing softness, weather conditions and opening reliability.

For small, lightweight rockets extra-small parachutes are often advisable since these models can reach extreme altitudes and drift considerable distances even in gentle breezes. The 38 square inches per ounce formula can be used to determine the parachute's size, but experience will be a better guide.

The effective area of a standard commercial parachute can be reduced in several ways. The shroudlines may be shortened or two lines taped together at the top to keep the parachute from opening completely. The center of the parachute may be cut out or the two color printed parachutes (PK series) may be cut on any of the inside circles to form smaller parachutes.

The opposite extreme in parachute size becomes important in duration contests. In such a contest a large, lightweight parachute is important to obtain the lowest possible descent rate. The area to weight ratio must be very high. Competitive duration models have ratios of from 300 to 500 square inches per ounce for calm weather. Models equipped like this can turn in times of 10 to 20 minutes.

THE TIME FACTOR

The period the parachute spends packed in the rocket while awaiting flight has a considerable effect on reliability. Plastic has a special tendency to take a "set," especially when cold. As a general rule the parachute should remain packed no longer than 1 hour in warm weather, 1/2 hour when the temperature is between 40° and 60°, and no more than 5 minutes when the temperature is 32° or less. In cold weather it is a good idea to prepare the rocket in a heated area and keep it warm until just before launching. If the parachute is in the rocket longer than the period recommended it should be removed from the rocket body, opened up, refolded and repacked before flight.

If these steps are followed carefully, parachute recovery can be highly reliable, spectacular and useful. It will prove its value again and again in demonstrations, payload launchings, contests and sport flying, and will provide an excellent basis for further experiments into rearward ejection, side ejection, booster recovery and many other special systems.

ENGINE MOUNTING

Ejection gases must pressurize the parachute compartment of a model if the parachute is to be ejected. If the engine is loose in the body it will be expelled rather than the parachute. If there are any holes the gas can leak through, it will, and the rocket will streamline in.

Use plenty of masking tape to hold engines in place. Wrap the engine with tape even if a wire engine holder is used to retain the engine, since an air-tight seal is needed. It is practically impossible to have the engine held in place too tightly.

WIND

Never fly rockets in high winds, since aerodynamically stabilized vehicles fly into the wind and will present a hazard if they take paths parallel to the ground. In addition, a parachute recovered rocket will drift for a considerable distance at the same speed as the wind. Thus in a 20 mile-an-hour breeze the model will drift at 20 mph--considerably faster than a normal person can run. In more moderate winds it is still important to use caution, but rockets can be flown without great difficulty if parachute size is kept within reasonable limits set by the weather conditions and rocket performance.

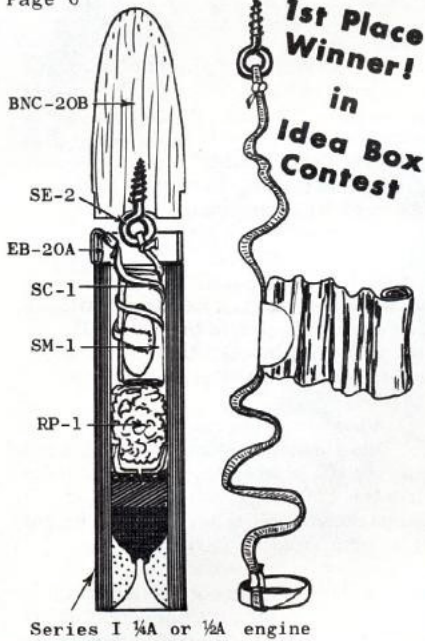

1st Place Winner!
in
Idea Box Contest

IDEA BOX

Danny Taylor of Fayetteville, N.C. shows us how to use the otherwise empty space in $\frac{1}{4}$ A and $\frac{1}{2}$ A Series I engines to make an ultra light rocket with streamer recovery.

Danny uses an EB-20A as engine block and shock cord anchor. An SE-2 screw eye in the nose cone (BNC-20B is used here) anchors the other end of the shock cord, with a section of SM-1 secured by a tape disc to the middle of the shock cord. Notice that all of this is stowed within the forward end of the engine casing on the upward flight.

As future issues of the MRN appear we will publish more of the winning suggestions from the Idea Box Contest.

Next time when cutting body tubes use a stage coupler and fine sand paper to dress down the tube ends. After making the cut, install the coupler and with a circular motion, move the tube end around on the sand paper. Hold the paper down firmly on a flat surface and the coupler will see to it that the tube is held vertically while achieving a smooth squared tube end.

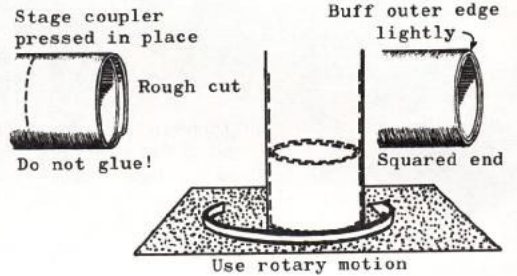

Series I $\frac{1}{4}$ A or $\frac{1}{2}$ A engine

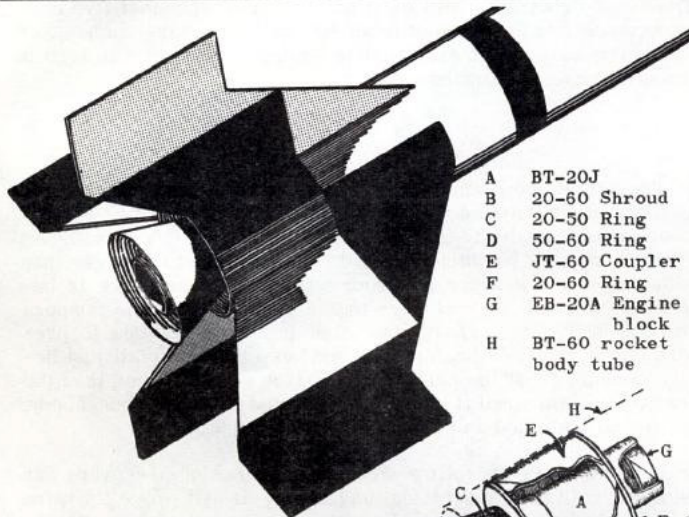

- A BT-20J
- B 20-60 Shroud
- C 20-50 Ring
- D 50-60 Ring
- E JT-60 Coupler
- F 20-60 Ring
- G EB-20A Engine block
- H BT-60 rocket body tube

Now add that extra touch to your semi-scale bird! This unit resembles the divergent section of the nozzle as used on many famous launch vehicles. It won't get you to the moon, but it can pretty up your rocket.

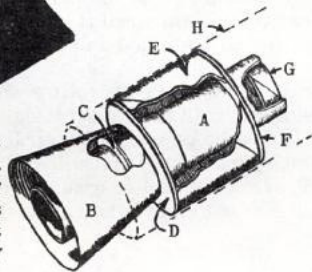

4th Place Winner!

A suggestion of JIM THOMPSON of OTTUMWA, IOWA, for flying with Series I or Series III engines. A 1" section of engine casing or 1" section of BT-40 cut and properly overlapped serves as a spacer between a Series III engine and engine block. This can be removed at will for use of the larger Series I engines above $\frac{1}{4}$ A class.

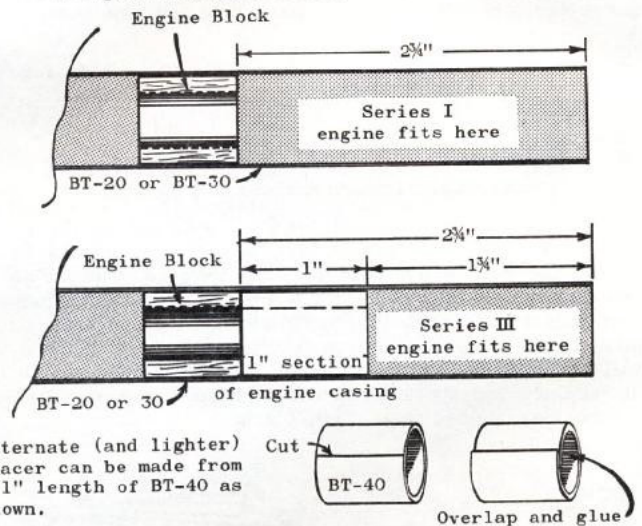

DAVID CHASNEY of DETROIT, MICHIGAN, is using an old toothbrush to remove the ejection charge deposits from the inside of his birds making the engines a lot easier to insert and insuring him a trouble free ejection every time.

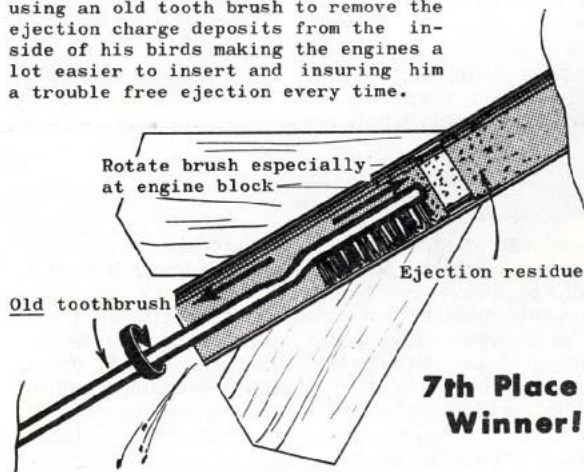

7th Place Winner!

One of the best ways we've found to quickly dry and cure a freshly painted rocket, no matter what the temperature or humidity, is to stand the rocket before an electric fan-circulated heater. This procedure is excellent for drying glue joints as well. Aside from suggesting that you revolve the rocket to promote even drying, we strongly advise that you place your rocket no closer than two feet from the heater. Closer, and you risk blistering your paint job.

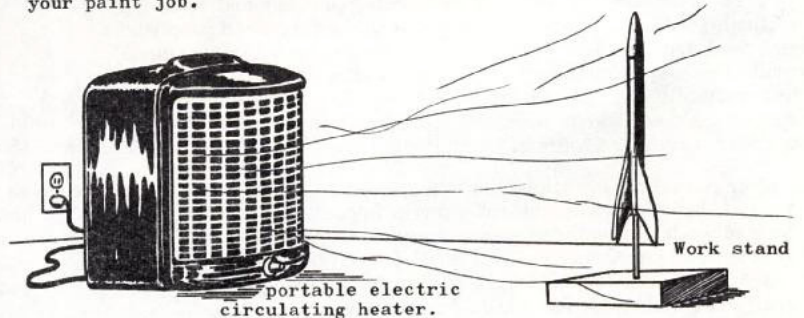

Estes Industries Rocket Plan No. 19

LOADLIFTER 1-A

Winning Design
Favorite Design Contest
by Merrell Lane

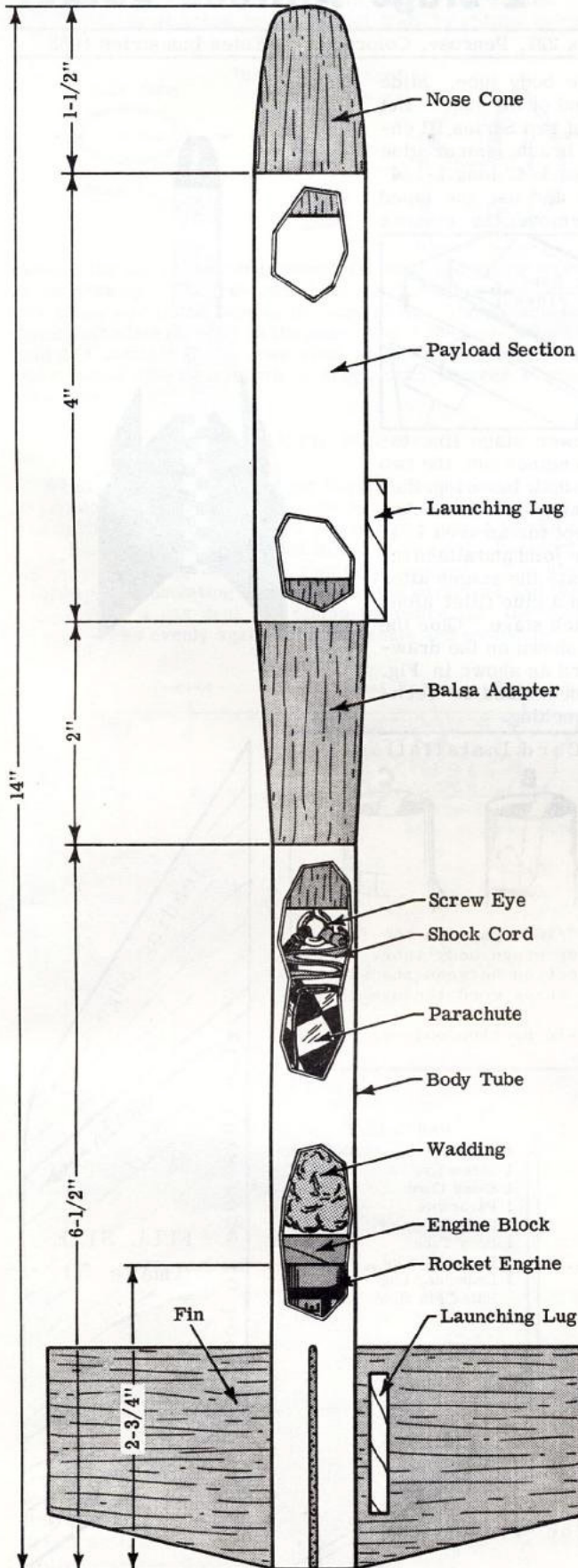

Assembly Instructions

Spread glue around the inside of one end of the 6-1/2" long body tube as far in as you can reach with your little finger. Insert an engine block and push it forward into the body tube with an empty engine casing. Move the block forward until the end of the engine casing is even with the end of the body tube (and the engine block is 2-3/4" from the end of the body). Remove the engine casing immediately.

Cut out four fins and glue them to the body tube. Be sure to match the grain on the balsa with the grain direction indicated on the fin pattern. Align each fin by sighting along the body and adjusting it until the fin is parallel to the body and projects straight away from it. After the glue has dried run a fillet of glue along each of the fin-body joints.

Glue the launching lugs into place as shown in the drawing. Apply glue to the large end of the balsa adapter and insert it into one end of the payload section tube. The nose cone should fit tightly in the other end of the payload tube. If it is too loose wrap its shoulder with tape to increase the diameter.

Attach the shock cord and recovery system as shown in the illustration. Paint the model and apply decals.

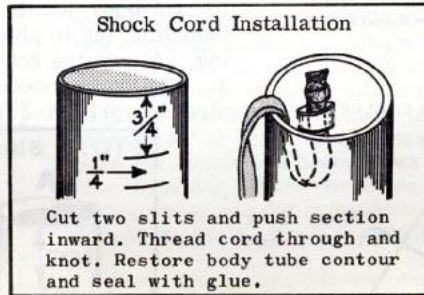

PARTS LIST

- 1 Nose Cone #BNC-50J
- 1 Body Tube #BT-50S
- 2 Launching Lugs #LL-1A
- 1 Balsa Adapter #TA-2050
- 1 Screw Eye #SE-1
- 1 Shock Cord #SC-1
- 1 Parachute #PK-12
- 1 Body Tube #BT-20D
- 1 Engine Block #EB-20A
- Balsa Fin Stock #BFS-20

Recommended Engines

- 1/4A, 8-2 1/2A, 8-2
- A, 8-3 B, 8-4
- B, 3-5

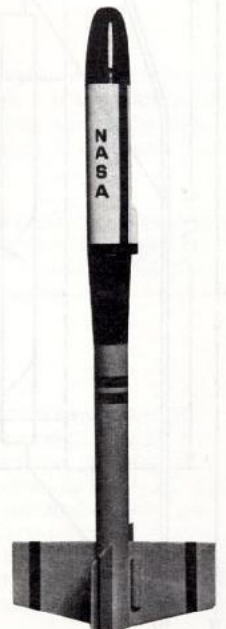
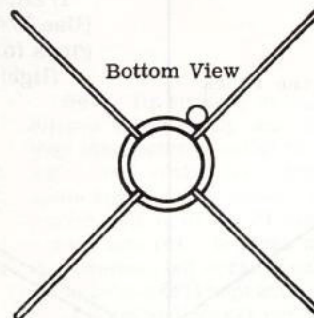
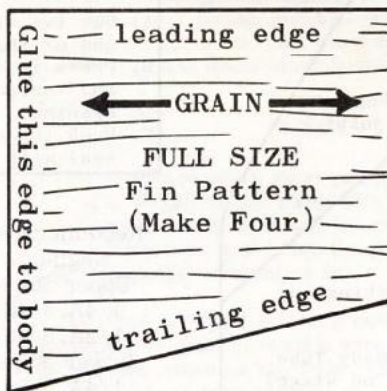

Estes Industries Rocket Plan No. 18

MMSV-II

2-Stage Altitude Rocket

Published as a service to its customers by Estes Industries, Inc., Box 227, Penrose, Colorado. © Estes Industries 1963

Apply glue to the last 1/4" of the inside of the 2-1/2" long lower stage body tube. Slide the engine block into the tube until the end of the block is even with the end of the tube. Let the glue dry. Wrap a layer of cellophane tape tightly around the joint of two Series III engines and slide them into the lower stage. Using your little finger or a brush, smear glue around the inside of the 3-1/2" long upper stage body tube to cover an area 1/4" long 1-1/4" from the end of the body tube. Insert an engine block into the body tube and use the taped engines and the lower stage body to slide the block into position. Remove the engines immediately.

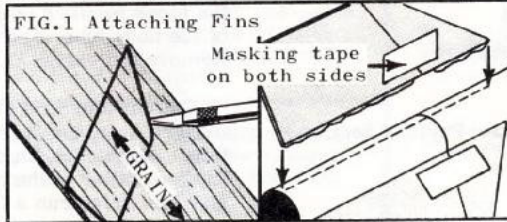
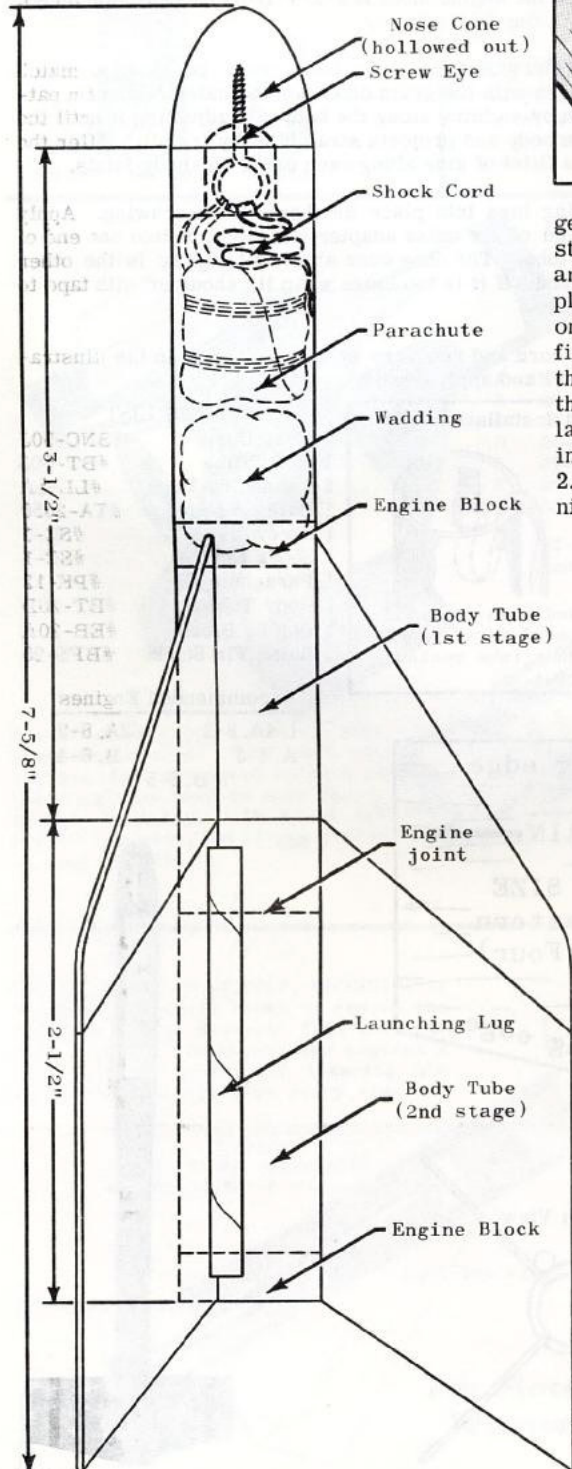

Tape the upper and lower stage fins together. Insert the taped engines into the two stages. They will hold the body tubes together and insure proper positioning of the fins. Apply glue to the fins except for an area 1/4" on either side of the stage joint and attach the fins to the rocket. Separate the stages after the glue has dried and run a glue fillet along the fin-body joints on each stage. Glue the launching lug in place as shown on the drawing. Attach the shock cord as shown in Fig. 2. Follow procedures described in Technical Report TR-2 for launching.

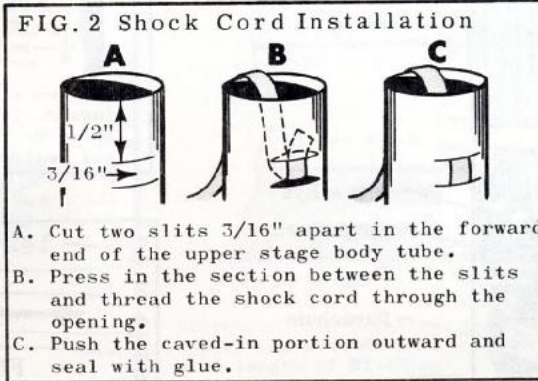

Recommended Engines
 Upper Stage
 1/4A. 8-4S
 1/2A. 8-4S
 Lower Stage
 1/4A. 8-0S
 1/2A. 8-0S
 (Use 1/4A engines for first flights.)

PARTS LIST

- | | |
|-----------------|----------|
| 1 Nose Cone | #BNC-20A |
| 1 Screw Eye | #SE-1 |
| 1 Shock Cord | #SC-1 |
| 1 Parachute | #PK-12 |
| 1 Body Tube | #BT-20J |
| 1 Body Tube | #BT-20G |
| 2 Engine Blocks | #EB-20A |
| 1 Launching Lug | #LL-1B |
| Balsa Fin Stock | #BFS-20 |

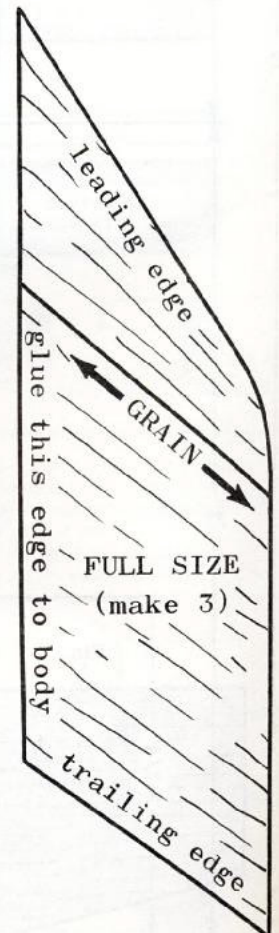
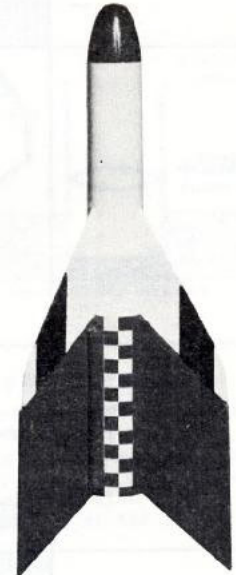
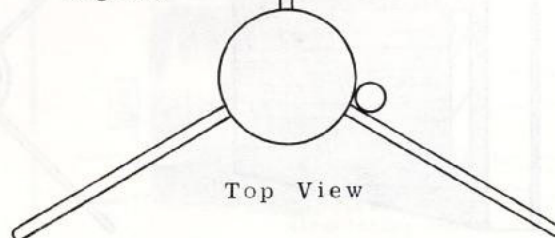

Estes Industries Technical Report TR-2

MULTI-STAGING

by Vernon Estes

These reports are published as a service to its customers by Estes Industries, Inc., Box 227, Penrose, Colorado.
Copyright 1963 by Estes Industries, Inc.

Multi-staging is one of the most prominent characteristics of modern rocketry. This technique is used with solid propellant rockets and liquid propellant rockets, in rockets less than a foot tall and in rockets which tower to over one hundred feet. Multi-stage rockets are used to send up payloads from ants to humans to 500 feet, into orbit, and on to other planets.

The performance necessary for high orbits, moon shots and interplanetary probes is provided by multi-stage rockets. The principle advantage of multi-staging is the elimination of unnecessary weight in the later portions of the rocket's flight. For example, compare two rockets weighing 1500 pounds at takeoff, one a single stage missile and the other a two stage rocket. The single stage rocket holds 1000 pounds of fuel inside a 500 pound body while the two stage rocket consists of two 250 pound bodies, each carrying 500 pounds of fuel. When half the fuel in the single stage rocket is used there is still another 1000 pounds for the remaining half of the fuel to carry. On the other hand, when half the total fuel load of the two stage rocket is used the stages separate, leaving 250 pounds of dead weight behind, with only 750 pounds for the remaining half of the fuel to move. This weight saving is even greater at burnout when the single stage rocket weighs 500 pounds and the multi-stage rocket only 250.

The principles of model rocketry and professional rocketry are identical although the model rocketeer uses somewhat different operating methods than the professional. The young rocketeer who masters the principles of multi-staging is gaining knowledge which he will find useful in his future career.

IGNITION

The lower or first stage of a multi-stage rocket is always ignited by standard electrical means. For further details, refer to the instruction sheet which is included with all rocket engines. The second stage ignition is accomplished automatically upon burnout of the first stage. As you will notice in figure 1A, the first stage engine has no delay or ejection charge. This is to assure instant ignition of the following stage upon burnout.

In figure 1B the propellant has been partially burned leaving a relatively large combustion chamber. As the propellant continues to burn, the remaining wall of propellant becomes thinner and thinner until it is too thin to withstand the high pressure inside the combustion chamber. At this point the remaining propellant wall ruptures, allowing the high pressure inside the combustion chamber to exhaust forward toward the nozzle of the next stage, carrying hot gases and small pieces of burning propellant into the nozzle of the second stage engine. This action is illustrated in figure 1C.

For this system to work, the rocket must be designed and built to make the best use of the operation of the engines. If the upper stage engine is simply placed

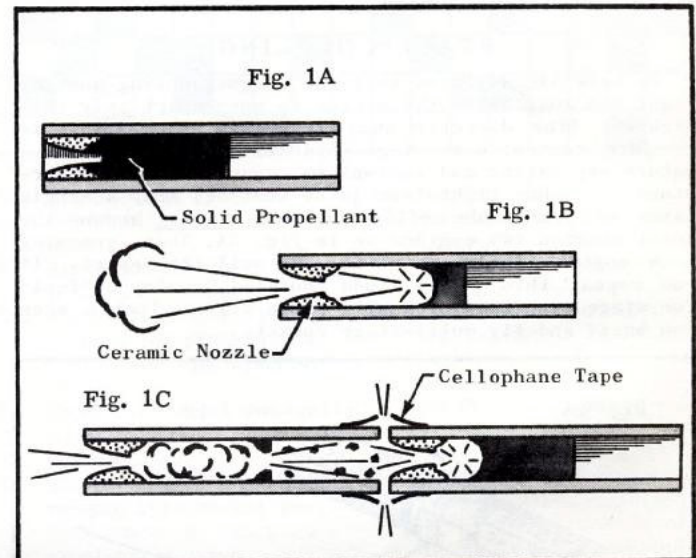

ahead of the booster engine so that the two can separate easily, ignition reliability may fall as low as 40 percent, depending on the type of booster used (except when a Series II engine is used in the upper stage, in which case reliability will be about 80 percent). This unreliability in ignition is the result of several causes. First, when the forward propellant wall of the booster burns through, high pressure is built up in the area between engines. This pressure will force the stages apart. Second, the nozzle of the upper stage engine is quite small (.009 square inches in a Series I engine), making a difficult target for the hot gases and burning particles. Also, the nozzle of the upper stage will cool gases slightly as they enter it.

These problems in multi-stage ignition led to an extensive research program at Estes Industries. Revisions in engine design, gimmicks such as pressure relief vents, etc., were tried, but none proved satisfactory. What was needed was a method of controlling stage separation so that the hot ignition gases would have a proper chance to act on the upper stage engine before the upper and lower stages parted company.

After data on several hundred test firings had been collected, the problem was reanalysed to find the factors which contributed most to reliability. There were two: An extremely tight joint between stages and a coupling which forced the two stages to move apart in a completely straight line.

The simplest, most reliable method of joining stages tightly was immediately considered--tape. By wrapping one layer of cellophane tape around the joint between engines and then recessing this joint 1/2" rearward in the booster body tube, as in fig. 2, reliability suddenly jumped to almost 100%. Thus it was discovered that the coupling system played the most important part in multi-stage ignition reliability.

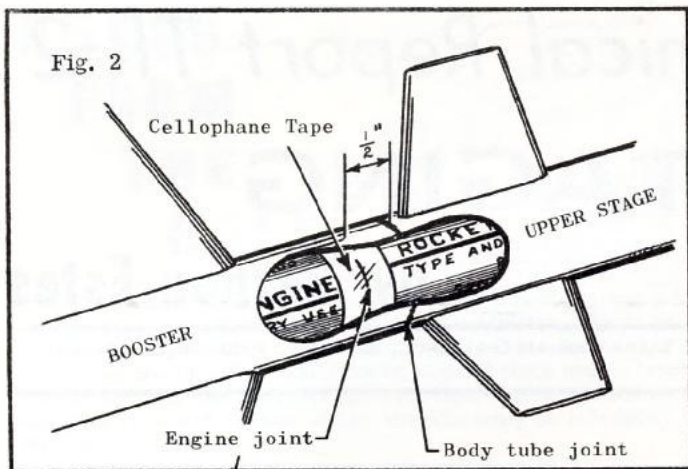

STAGE COUPLING

We have already seen that the stage coupling must be tight and must allow the stages to move apart only in a straight line directly away from each other. This is to gain control over stage separation, preventing premature separation and incomplete separation. To understand just how tight this joint must be, wrap a single layer of 1/2" wide cellophane tape tightly around the joint between two engines as in fig. 3A. Then, grasping each engine firmly as in fig. 3B, pull them apart. If you repeat this a few times you will develop a "feel" for stage coupling which will prove very valuable when you build and fly multi-stage rockets.

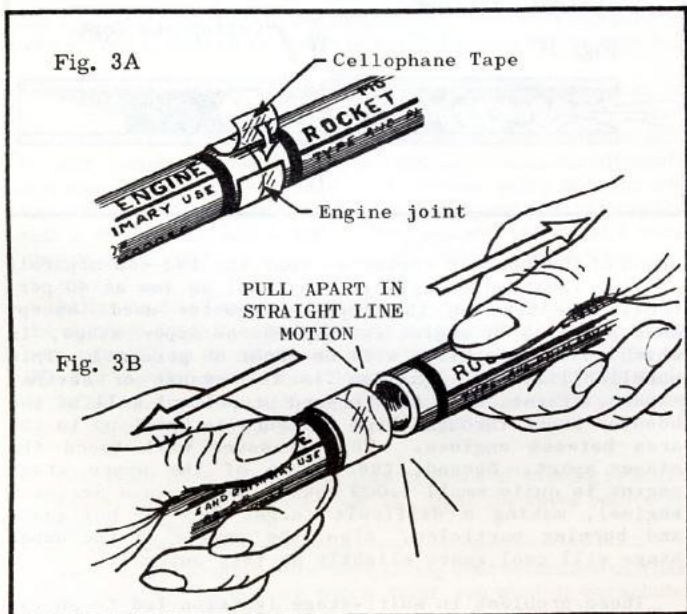

The proper coupling system to use in a rocket will depend on the size of the body tube. The coupling system for rockets using tubes of approximately 3/4" diameter (BT-20, BT-30, and BT-40) is shown in fig. 4. With this system the upper stage engine must project at least 1/2" rearward into the booster body tube to provide straight line separation. The engines are taped together before being inserted into the rocket. Check carefully before and after taping to be sure the engines are in their proper positions (nozzle of upper stage engine against top end of booster engine). Failure to check carefully can be highly embarrassing as well as damaging to the rocket.

When the engines are taped together they can be inserted into the rocket. Wrap masking tape around the upper stage engine at the front and near the rear as in fig. 5 to give it a tight fit in the body and push it into place. Then wrap the booster engine and push the booster into position. Failure to get the upper stage engine in place tightly enough will result in the recovery system malfunctioning, while failure to get the booster on tightly can result in its dropping off under

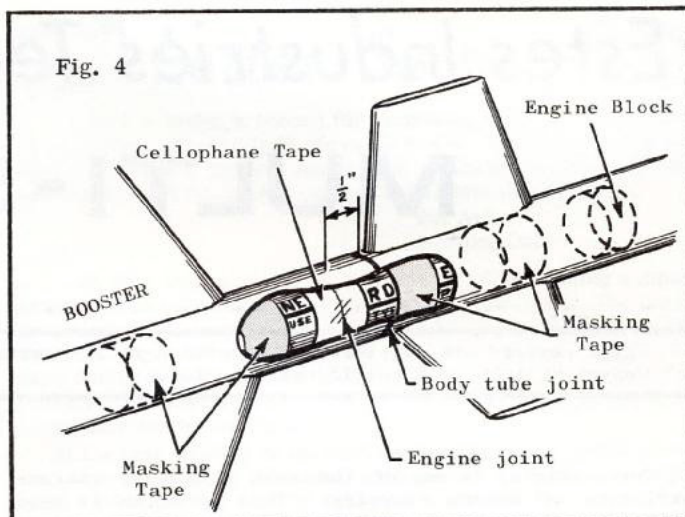

acceleration, leaving the entire engine unit dangling from the upper stage while the rocket loops around in the air.

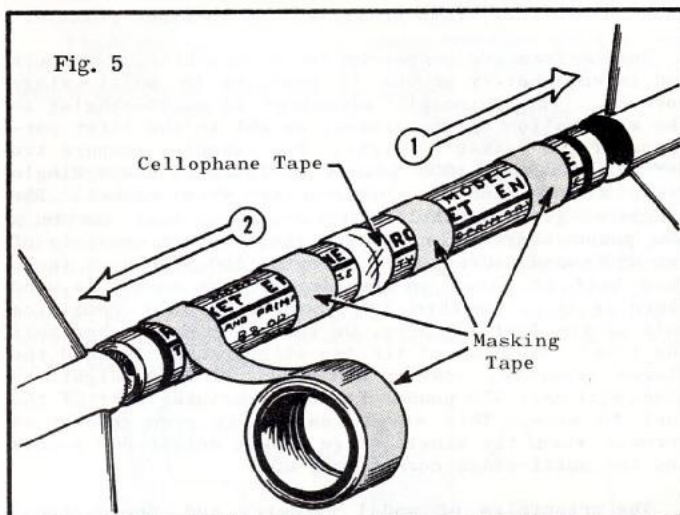

The procedures used for two stage rockets should also be used on rockets with more stages. It is important, however, to get considerable experience with two stage rockets before attempting to design a 3 or 4 stage model.

Rockets using large diameter tubes (BT-50 and BT-60) require somewhat different methods, but the same principles of tight coupling and straight line separation must be followed. The recommended coupling method for larger diameter tubes is illustrated in fig. 6. The stage coupler is glued to the booster body tube, with the adapter for the upper stage engine mounting positioned forward to allow the stage coupler to fit into the upper stage, while the tube adapter in the booster is positioned to the rear.

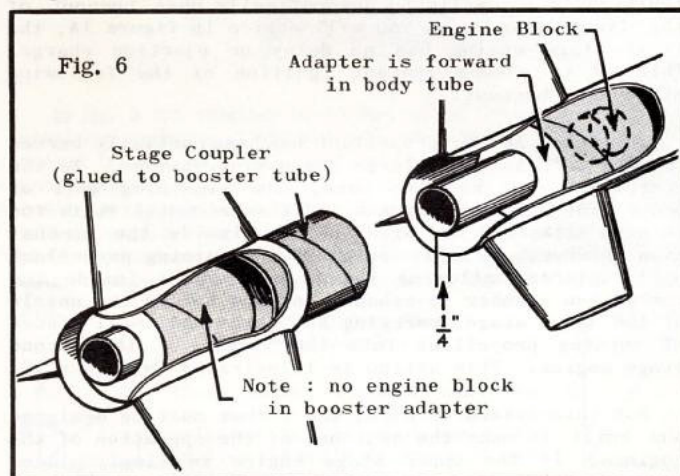

The most satisfactory method of mounting engines in rockets with large diameter tubes involves positioning the upper stage engine holder tube to project 1/4" rearward from the end of the main body and positioning the engine block so the engine projects 1/4" rearward from the end of the engine holder tube (see fig. 7). This allows the engine to be held in place in its mounting by wrapping a layer of masking tape tightly around the end of the tube and the engine as in fig. 7B. The engine mounting in the booster must be built to leave space for this engine mounting (see fig. 7C).

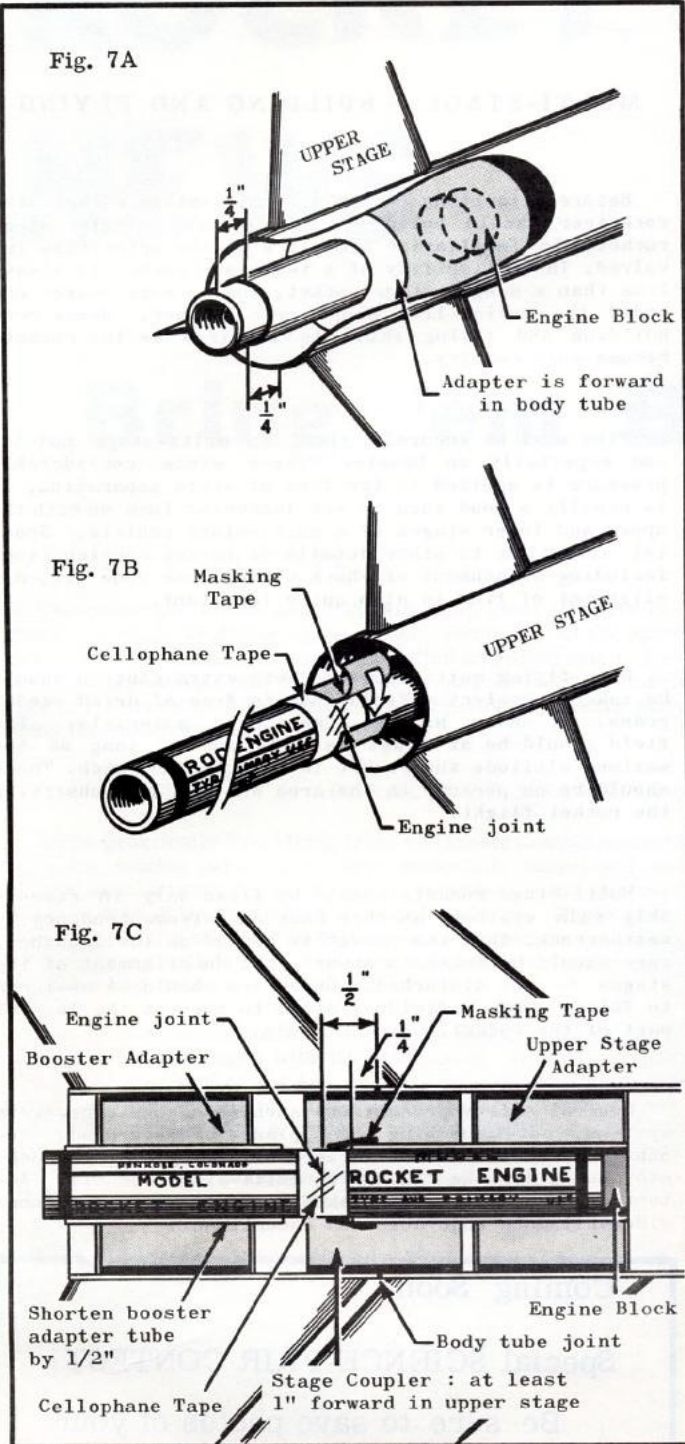

Normal procedures call for taping the engines together with cellophane tape before mounting in the rocket. By doing this a better coupling is achieved. Figure 8 illustrates a slightly different method, recommended for use with Series I and Series III boosters only. Applying tape to the outside of the rocket is easier than taping the engines, but is also poor aerodynamic practice.

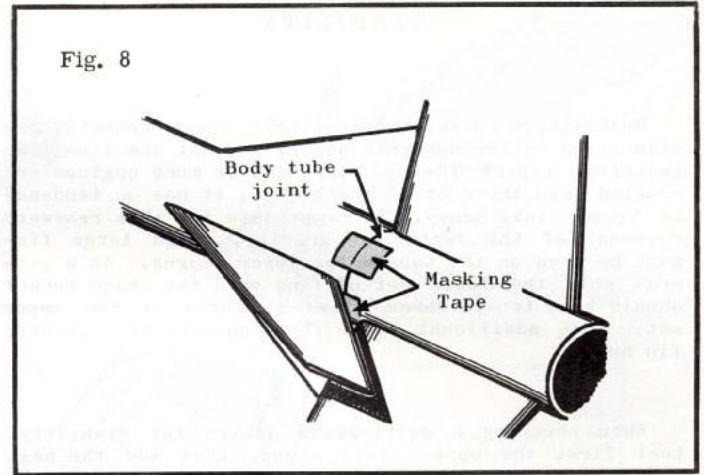

With any coupling system, certain rules must be carefully followed. Engines must be held in their respective stages securely. Engine blocks must be strongly glued. Engines may be secured in their body tubes by (1) wrapping tape around the middle of the engine until it makes a very tight friction fit in the body as in fig. 9A, (2) taping the end of the engine to the engine holder tube as in fig. 9B, or (3) by a combination of wrapping the engine with tape and properly positioning engine blocks as in fig. 9C.

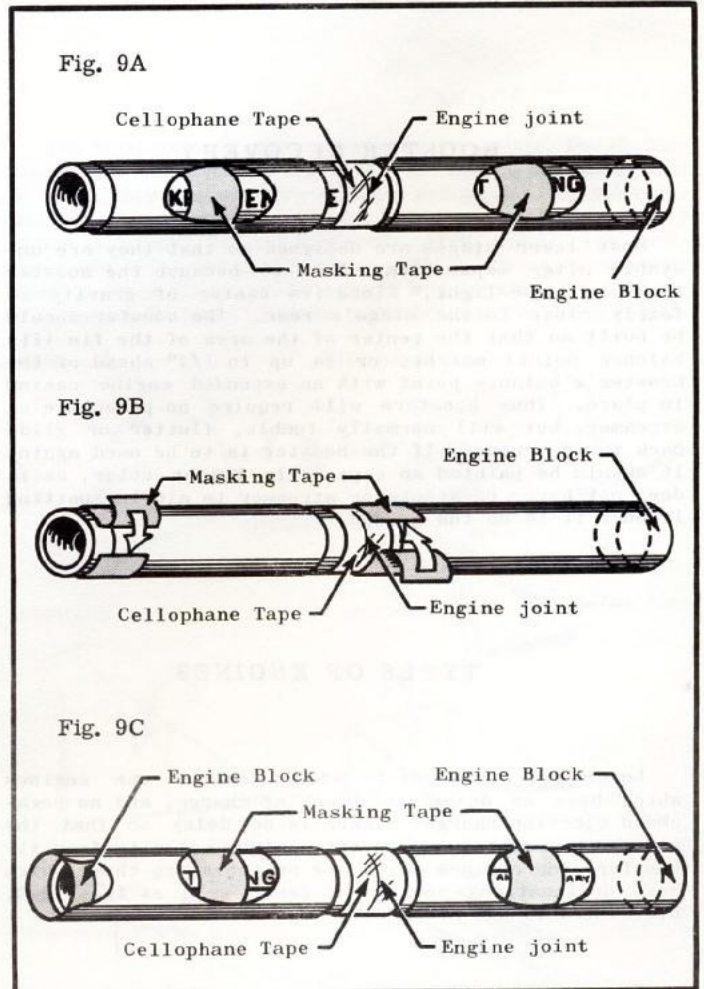

When the forward wall of propellant in the booster ruptures and hot gases blow forward, the joint between the engines is pressurized. If the rocket has been constructed with proper care and the engines mounted carefully, the tape that holds the stages together will break, allowing the stages to separate, but not until the upper stage has ignited. If proper care is not exercised, almost anything can happen.

STABILITY

Multi-stage rockets, like single stage rockets, are stabilized by air currents acting against the fins (see technical report TR-1). Since two or more engines are mounted near the rear of the rocket, it has a tendency to become tail-heavy. To compensate for this rearward movement of the center of gravity, extra large fins must be used on the booster or lower stages. As a general rule the lower set of fins on a two stage rocket should have two to three times the area of the upper set. Each additional stage then requires even greater fin area.

When checking a multi-stage design for stability, test first the upper stage alone, then add the next lower stage and test, and so on. In this manner the builder can be sure that his rocket will be stable in each step of its flight, and he will also be able to locate any stage which does not have sufficient fin area. Always check for stability with engines in place.

To obtain the maximum stability from the fin area, care should be taken in construction to create an aerodynamically "clean" shape. The transitions between stages should be as smooth as possible to prevent interrupting the air flow and causing turbulence.

BOOSTER RECOVERY

Most lower stages are designed so that they are unstable after separation. This is because the booster alone is "nose-light," since its center of gravity is fairly close to the stage's rear. The booster should be built so that the center of the area of the fin (its balance point) matches or is up to 1/4" ahead of the booster's balance point with an expended engine casing in place. Thus boosters will require no parachute or streamer, but will normally tumble, flutter or glide back to the ground. If the booster is to be used again, it should be painted an especially bright color, as it does not have a parachute or streamer to aid in spotting it once it is on the ground.

TYPES OF ENGINES

Lower and intermediate stages always use engines which have no delay and tracking charge, and no parachute ejection charge. There is no delay so that the next stage will receive the maximum velocity from its booster. The engines which are suitable are those which have designations ending in zero, such as the A.8-0, B.8-0, 1/4A.8-0S, and B 3-0.

The selection of booster engines will depend on several factors, including the rocket's stability and weight, launch rod length, and weather conditions. Generally heavy rockets and rockets with large fin area should use 1/4A, 1/2A, or B 3 booster engines unless there is no wind blowing. Experience has shown that even a gentle breeze is enough to make these models weather-cock severely, resulting in a loss of altitude and a long chase after the rocket. This is especially so when engines other than those mentioned are used.

In the upper stage an engine with a delay and tracking charge and parachute ejection charge is used. As a general rule the longest possible delay should be used, as multi-staging imparts considerably more velocity to the final stage, and the rocket must have an opportunity to lose this velocity before the parachute is ejected. Greater altitude will be obtained and damage to the recovery system avoided in this manner. Engines suitable for upper stage use are those with long delays such as the B.8-6, A.8-4, B 3-5, etc.

MULTI-STAGE -- BUILDING AND FLYING

Before attempting to build a multi-stage rocket, the rocketeer should build and fly several single stage rockets to familiarize himself with the principles involved. The reliability of a two stage rocket is always less than a single stage rocket, and as more stages are added the reliability drops even farther. Hence more building and flying skill is required as the rockets become more complex.

Fins must be securely glued on multi-stage models, and especially on booster stages since considerable pressure is applied to the fins at stage separation. It is usually a good idea to put launching lugs on both the upper and lower stages of a multi-stage vehicle. Special attention to other details of rocket construction, including attachment of shock cords, nose cone fit, and alignment of fins is also quite important.

When flying multi-stage rockets extra caution should be taken to select a field that is free of dried weeds, grass, or other highly combustible materials. The field should be at least as wide and as long as the maximum altitude the rocket is expected to reach. There should be no persons in the area who are not observing the rocket flight.

Multi-stage rockets should be flown only in reasonably calm weather, as they have an extreme tendency to weathercock. When the rocket is placed on the launcher, care should be taken to assure that the alignment of the stages is not disturbed. Observers should be assigned to follow each individual stage to prevent the loss of part of the rocket.

General safety precautions such as adequate recovery systems, not launching when planes are overhead, and others which are normally taken with single stage rockets should also be taken with multi-stage rockets. Attention to safety rules makes rocketry activities considerably more enjoyable and educational.

Coming Soon:

Special SCIENCE FAIR CONTEST!

Be sure to save photos of your project and a copy of your report: This contest will be open to any project using model rocketry.

Rules and more information in the next issue of the MRN.

STABILITY

Multi-stage rockets, like single stage rockets, are stabilized by air currents acting against the fins (see technical report TR-1). Since two or more engines are mounted near the rear of the rocket, it has a tendency to become tail-heavy. To compensate for this rearward movement of the center of gravity, extra large fins must be used on the booster or lower stages. As a general rule the lower set of fins on a two stage rocket should have two to three times the area of the upper set. Each additional stage then requires even greater fin area.

When checking a multi-stage design for stability, test first the upper stage alone, then add the next lower stage and test, and so on. In this manner the builder can be sure that his rocket will be stable in each step of its flight, and he will also be able to locate any stage which does not have sufficient fin area. Always check for stability with engines in place.

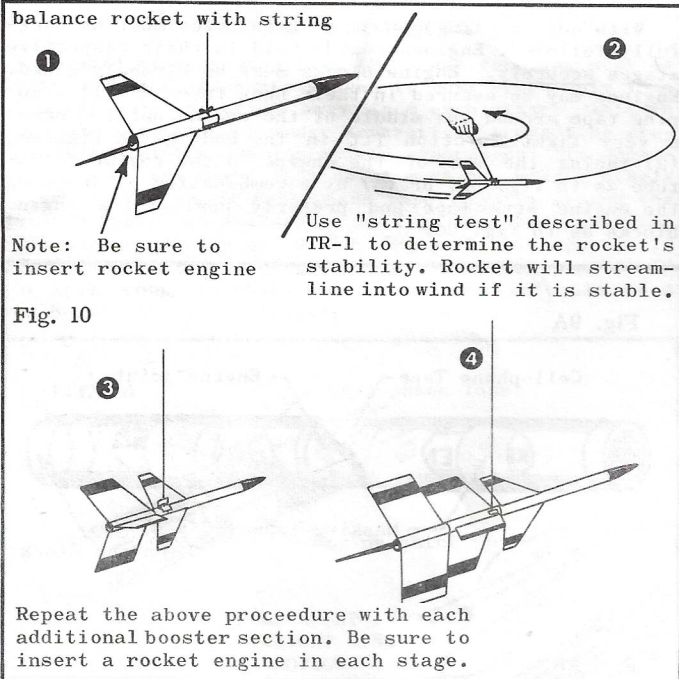

To obtain the maximum stability from the fin area, care should be taken in construction to create an aerodynamically "clean" shape. The transitions between stages should be as smooth as possible to prevent interrupting the air flow and causing turbulence.

BOOSTER RECOVERY

Most lower stages are designed so that they are unstable after separation. This is because the booster

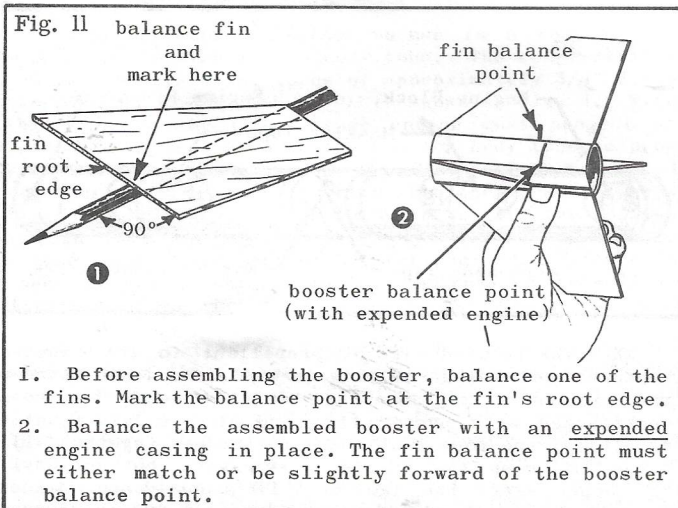

alone is "nose-light," since its center of gravity is fairly close to the stage's rear. The booster should be built so that the center of the area of the fin (its balance point) matches or is up to 1/4" ahead of the booster's balance point with an expended engine casing in place. Thus booster's will require no parachute or streamer, but will normally tumble, flutter or glide back to the ground. If the booster is to be used again, it should be painted an especially bright color, as it does not have a parachute or streamer to aid in spotting it once it is on the ground.

TYPES OF ENGINES

Lower and intermediate stages always use engines which have no delay and tracking charge, and no parachute ejection charge. There is no delay so that the next stage will receive the maximum velocity from its booster. The engines which are suitable are those which have designations ending in zero, such as the A.8-0, B.8-0. 1/4A.8-0S, and B 3-0.

The selection of booster engines will depend on several factors, including the rocket's stability and weight, launch rod length, and weather conditions. Generally heavy rockets and rockets with large fin area should use 1/4A, 1/2A, or B 3 booster engines unless there is no wind blowing. Experience has shown that even a gentle breeze is enough to make these models weather-cock severely, resulting in a loss of altitude and a long chase after the rocket. This is especially so when engines other than those mentioned are used.

In the upper stage an engine with a delay and tracking charge and parachute ejection charge is used. As a general rule the longest possible delay should be used, as multi-staging imparts considerably more velocity to the final stage, and the rocket must have an opportunity to lose this velocity before the parachute is ejected. Greater altitude will be obtained and damage to the recovery system avoided in this manner. Engines suitable for upper stage use are those with long delays such as the B.8-6, A.8-4, B 3-5, etc.

MULTI-STAGE -- BUILDING AND FLYING

Before attempting to build a multi-stage rocket, the rocketeer should build and fly several single stage rockets to familiarize himself with the principles involved. The reliability of a two stage rocket is always less than a single stage rocket, and as more stages are added the reliability drops even farther. Hence more building and flying skill is required as the rockets become more complex.

Fins must be securely glued on multi-stage models, and especially on booster stages since considerable pressure is applied to the fins at stage separation. It is usually a good idea to put launching lugs on both the upper and lower stages of a multi-stage vehicle. Special attention to other details of rocket construction, including attachment of shock cords, nose cone fit, and alignment of fins is also quite important.

When flying multi-stage rockets extra caution should be taken to select a field that is free of dried weeds, grass, or other highly combustible materials. The field should be at least as wide and as long as the maximum altitude the rocket is expected to reach. There should be no persons in the area who are not observing the rocket flight.

Multi-stage rockets should be flown only in reasonably calm weather, as they have an extreme tendency to weathercock. When the rocket is placed on the launcher, care should be taken to assure that the alignment of the stages is not disturbed. Observers should be assigned to follow each individual stage to prevent the loss of part of the rocket.

General safety precautions such as adequate recovery systems, not launching when planes are overhead, and others which are normally taken with single stage rockets should also be taken with multi-stage rockets. Attention to safety rules makes rocketry activities considerably more enjoyable and educational.