

MODEL ROCKET NEWS

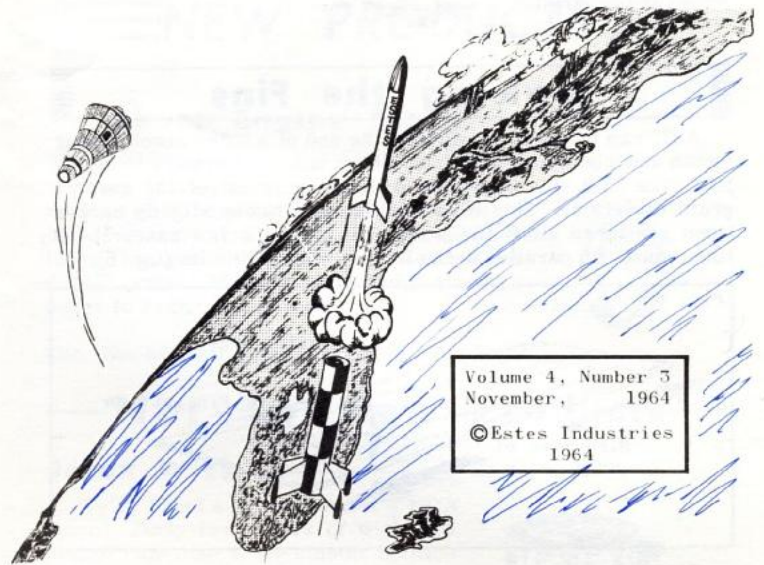

Build It Right The First Time!

More than one newcomer to model rocketry has uncorked his first box of supplies, stared at it and wondered: "Okay, so now whadda I do with it?" Even worse, many an experienced rocketeer has stared at another's latest creation and asked, "What is it--a flying garbage scow?"

The way a model rocket is built makes a world of difference both in its looks and flight. A rocket that is simply thrown together will show it on the ground and in the air. On the other hand, a carefully constructed model is a thing to be proud of. It gives people a good impression of the builder and it gives top performance time after time.

The best way to learn correct techniques is to use them. The Sly Bolt (plan on page 7) is a good model for this purpose. When building it refer back to this article. Once one rocket has been built correctly, others will come almost naturally.

Crooked, unevenly spaced fins are obvious signs of a careless rocketeer. Prepare a fin spacing guide as in fig. 3A, wrap it around one end of the body and mark. Locate a "V" notch in a cabinet, etc., lay the tube in the notch and draw a line through each mark. (See fig. 3B.)

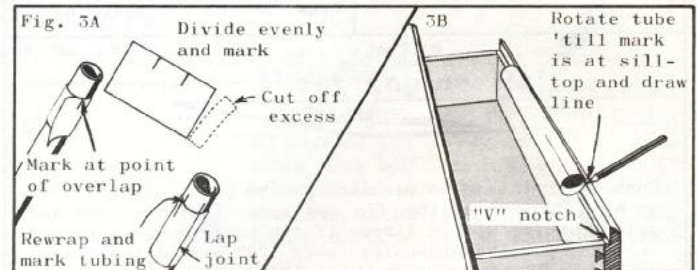

If the model uses an engine block to position the engine in the body, smear a liberal amount of glue around the inside of the tube about 2 inches from the end with the fin alignment marks. Use your little finger or a brush to apply the glue. Place the block in the end of the tube, push it in to the position specified in the plans with an empty engine casing and remove the casing immediately (fig. 4).

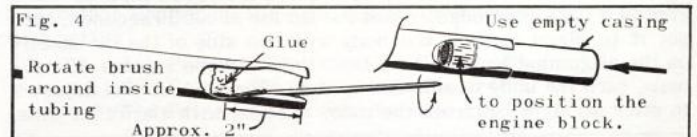

On models using a strap engine holder mark the tube exactly between two fin spacing marks at the specified distance from the rear (use a ruler and measure). Cut a 1/10" slit in the tube through the mark. Push one end of the holder into the hole so its long section lies flat against the body. Sight down the tube, align the holder parallel to the body and anchor its rear in place with masking tape. Glue the holder in place as shown in fig. 5.

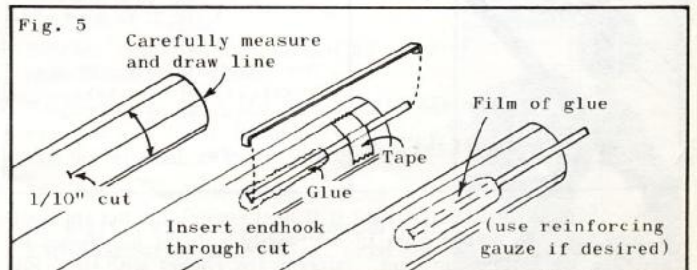

Preparing the Body Tube

There are two purposes in tube cutting--to get the correct body length and to obtain clean, square ends. Begin by sanding one end of the body as shown in fig. 1 to even it up. Then meas-

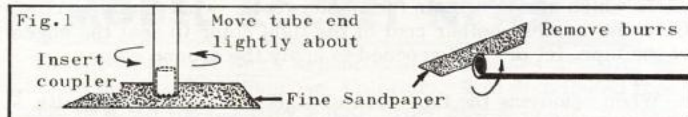

ure the correct distance from the clean end with a ruler and mark the tube at this point--don't guess. Make a tube cutting guide as in fig. 2A, wrap it around the body exactly on the mark

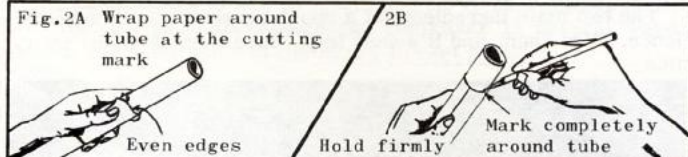

and draw a straight line all the way around the tube (fig. 2B). Cut the body with a sharp knife, following the exact center of the line (fig. 2C). Sand this end the same way as the first end.

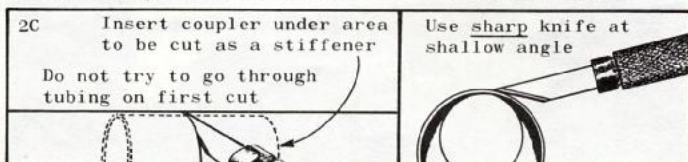

Making the Fins

A fin can be made by sticking the end of a balsa sheet in your mouth and chomping down, but there are better ways to do the job. The first rule in proper fin making is to get the correct grain direction. This direction is indicated by slightly darker lines scattered along the wood. In all but a few cases these lines must run parallel to the leading edge of the fin (fig. 6).

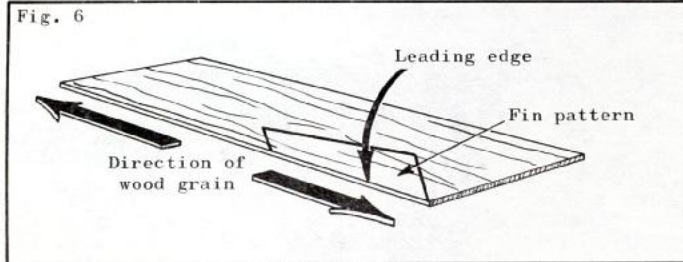

The three main methods of transferring fin patterns to the balsa are illustrated in fig. 7. Whichever method is used, align the pattern properly, then follow the lines exactly in marking.

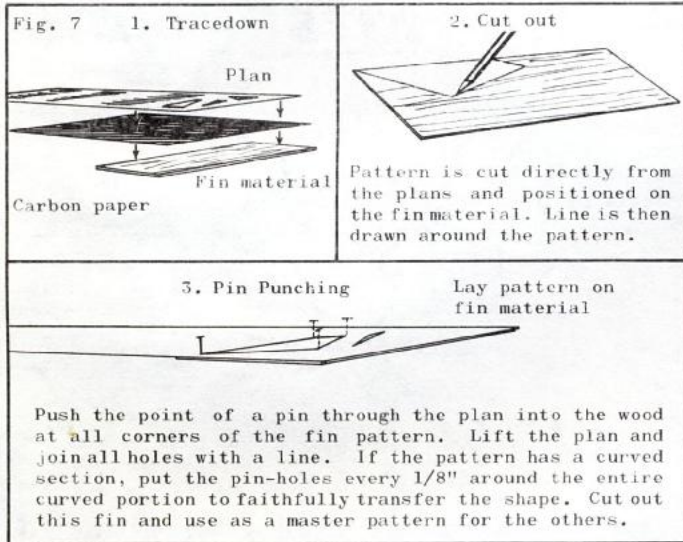

Use an extra sharp knife or single edge razor blade to cut out the fins. Cut along the center of the line with light pressure. Make several strokes along a line with the blade to cut through rather than try to cut all the way in one stroke.

To attach the fins to the body apply a thin, even layer of white glue to a fin's root edge. Hold the fin for about 30 seconds, then put it in place against the body with one side of the fin exactly on the alignment line on the tube. Hold it there another 30 seconds, turn the body upside down, sight along the fin and adjust it to stick straight out from the tube. Repeat with the other fins,

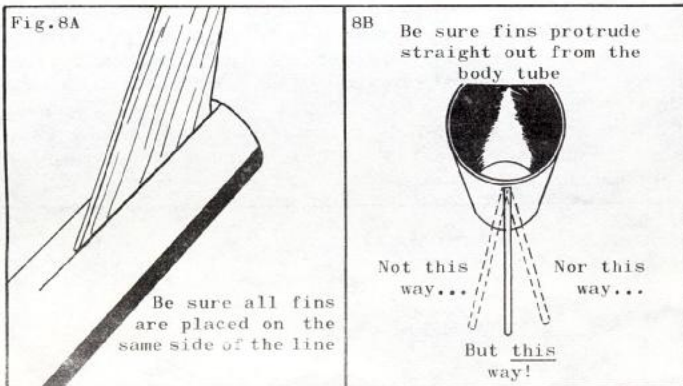

double-check alignment (correct it if necessary) and set the unit aside to dry. When the glue is dry apply a fillet as shown in fig. 8C to each fin-body joint. Support the rocket with the body

level until the fillet dries. (Do not set it on its fins!)

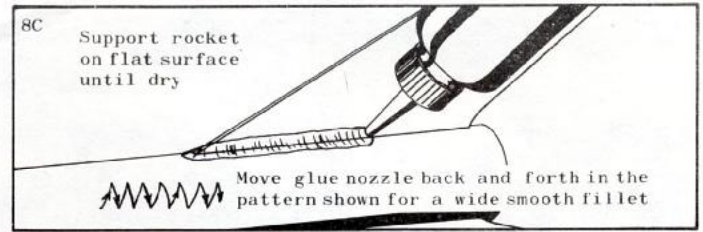

Final Steps

Slit the body at the front as shown in the drawing. Knot the end of the shock cord, thread it through the slits and glue it in place as in fig. 9. While this dries apply glue to one side of the launching lug. Attach it to the body either between two fins



or in the corner between a fin and the body tube (depending on which position the plans show).

Insert the screw eye into the base of the nose cone. Remove it, squirt glue into the hole and reinsert the screw eye (fig. 10).

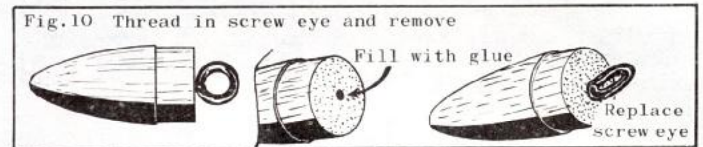

The rocket should be painted only after all glue has dried completely. Paint cannot replace sandpaper, so use extra fine sandpaper and keep using it until every balsa surface is perfectly smooth. Apply an even coat of sanding sealer to the wood, let it dry--and sand some more. Repeat this operation until all the pores in the wood are sealed.

Most rocketeers get best results with spray enamel paint. It is easy to apply, fast drying and gives a durable, glossy finish. Instead of trying to do all the painting with one squirt from the can, apply several thin but even coats, allowing the rocket to dry in a dust-free area between coats.

If the rocket is to be painted a fluorescent color give it an even, white undercoat first. This brings out the full effect of the fluorescent paint. For a two-tone paint job apply the lighter color first, let it dry completely (at least one day) and cover all parts which are to remain the lighter color with masking tape. Give the model another coat of the light color to seal the edges of the tape, let dry and proceed to apply the second color.

When removing the tape scratch lightly along its edge with a very sharp knife to prevent peeling the paint when the tape is lifted. To touch up any goofs squirt paint onto a sheet of waxed paper and apply it carefully with a small brush.

The two main ingredients of a good rocket are care and patience. Use them and it's easy to produce a great model every time.

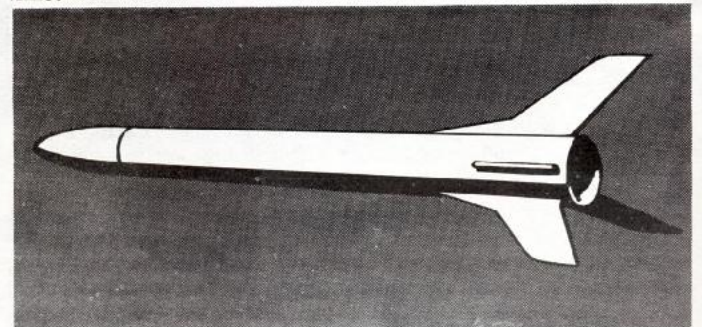

CONTEST WINNERS!

Multi-Stage Rocket

Place	Winner	Rocket
1st	Ronald Tessendorf, Mondovi, Wis.	Deacon
2nd	Carl Hynes, Kenmore, New York	Optima
3rd	Danny Elliot, Tampa, Florida	(nameless)
4th	Wayne Kinashito, Hilo, Hawaii	Viking II
5th	Danny Taylor, Fayetteville, N. C.	Venus III
6th	Craley Society of Rocket Technology Indianapolis, Indiana	Bison
7th	James P. Fox, Pottsville, Pa.	Flying Fox
8th	David F. Craft, Jr., Worcester, Mass.	Pegasus-III
9th	Jonathan Weinberg, Dewitt, New York	Jeanyip
10th	David Greig, Hinckley, Minn.	Troposphere TR-2

Boost-Glider

Place	Winner	Rocket
1st	David Williams, Loogootee, Indiana	Eagle
2nd	George Jakenta, Pittsburgh, Pa.	(nameless)
3rd	Bill Bever, Elwood, Illinois	Pioneer I
4th	Richard Warner, Culver, Indiana	Kinky I
5th	Howard Rotz, Floral Park, New York	Aeolus 15
6th	Alan Hathway, Thomaston, Conn.	Sky Bolt C
7th	Jim Kobus, Plainview, New York	Warhawk 2-C
8th	Gary Adams, Florence, Kentucky	Sky Schooner 3X
9th	Sven Donaldson, Woodstock, New York	The Bat
10th	Jon Lown, Kingston, New York	Hi-Fli III

Science Fair Project

1st Place; Gordon Mandell, Great Neck, New York; "Research and Development in Improved Boost-Glide Methods." This project was a study of the factors influencing front engine boost-glider operation. (For a condensed version of the results of the research, see Technical Report TR-7 on page 10.)

2nd Place; Jeffrey Owens, Brookfield, Wisconsin; "The Krushnic Effect." The project consisted of research into the nature of the effect and its probable causes.

3rd Place; William L. Luken, Jr., Dayton, Ohio; "Mathematical Analysis of Drag." The project involved research to derive formulas to describe the effect of drag on model rockets.

4th Place; Dan Masys, Columbus, Ohio; "Aerodynamics: Drag and its Effect on Vehicle Efficiency." This was an exploration of the relationship of the amount of drag surface to vehicle efficiency.

MODEL ROCKET NEWS

The Model Rocket News is published four times annually by Estes Industries, Inc., Penrose, Colorado. It is distributed free of charge to all the company's mail order customers from whom a substantial order has been received within a period of one year. The Model Rocket News is distributed for the purpose of advertising and promoting a safe form of youth rocketry and for informing customers of new products and services available from Estes Industries. Rocketeers can contribute in several ways towards the publication of the Model Rocket News:

- (1) Write to Estes Industries concerning things you and your club are doing in this field which might be of interest to others.
- (2) Continue to support the company's development program by purchasing rocket supplies from Estes Industries, as it is only through this support that free services such as the Model Rocket News, rocket plans, etc., can be made available. This support also enables the company to develop new rocket kits, engines, etc.
- (3) Write to the company about their products and tell what you like, what you don't like, new ideas, suggestions, etc. Every letter will be read carefully, and every effort will be made to give a prompt, personal reply.

Vernon Estes
Publisher

William Simon
Editor

NEW PRODUCTS

Short Engine Block

Designed especially for use as an engine retainer in the booster section of two stage rockets or as an extra-light engine block in high performance models. Fits BT-20 body tubes, measures only 1/8" long and weighs 0.0045 ounce. Made of special high strength paper to resist heat and wear.



Cat. No. 641-EB-20B \$.10 each, 3 for \$.20

Not - So - New Products

Jetex Wick

We've found a source, and it's back again! Forty-two inches of wick in a sealed can--use it for cluster ignition (see Technical Report TR-6).



Cat. No. 641-JW-1 \$.35 each

Engine Holder

New flat spring steel design gives easy installation and low drag. Recommended especially for sport and demonstration models built from BT-20 and BT-30, the engine holder is 2.8" long, 0.1" wide and only 0.025" thick. Mount it on the model with glue and gauze as shown. Net weight 0.032 oz. each, shipping weight 1 oz.

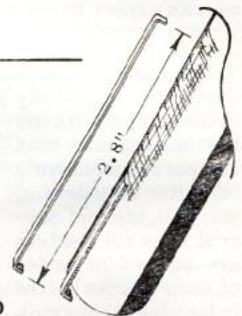

Cat. No. 641-EH-2 \$.15 each, 3 for \$.30

Short Engine Holder

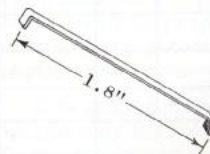

Specially designed for use with Series III engines and BT-20 and BT-30 body tubes, this holder is 1.8" long and 0.1" wide for the same easy installation and low drag as the standard model. Net weight 0.022 oz. each, shipping weight 1 oz.

Cat. No. 641-EH-3 \$.15 each, 3 for \$.30

PHOTO CONTEST

Here's one for you hot-dog photogs! Send in your favorite picture (or pictures) of model rocket activities, launchings, etc., to: Photo Contest, Box 227, Penrose, Colorado 81240. Entries will be judged on picture quality and subject interest. If you clicked that shutter at the right time, you may win one of these great prizes!

- 1st Prize--\$50 in merchandise credit.
- 2nd Prize--\$25 in merchandise credit.
- 3rd Prize--\$10 in merchandise credit.
- 4th Prize--\$5 in merchandise credit.
- 5th through 10th Prizes--Aerobee 300 kits.

Contest Rules

- 1) Each entry must consist of a photograph accompanied by a sheet of paper bearing the name and address of the entrant, the type of camera used and the type of film.
- 2) Entries must be postmarked no later than January 31, 1965.
- 3) Employees of Estes Industries, Inc. and members of their immediate families are not eligible to enter this contest.
- 4) The decision of the judges is final.
- 5) All entries will become the property of Estes Industries, Inc. No material can be returned.



NOTES FROM THE BOSS

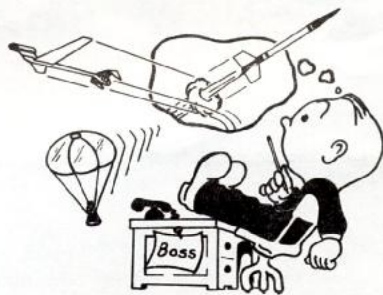

This year's E. I. Science Fair contest brought in quite a few excellent entries. According to the judges, the average project was better than the average for last year's contest. There were more projects involving original research, better reports and generally better displays. Everyone who took the time and effort to enter the contest has good reason to be proud of himself.

There will be another contest next year and now is the time to start preparing for it. The official announcement and rules will be carried in Vol. 5, No. 1 of the MRN, but the rules will be basically the same as this year. If present trends continue, we can expect to see even bigger and better projects next year.

Speaking of contests, the inset below shows the form that is used for preliminary judging in rocket design contests. The 20 to 30 designs with the best scores are then compared extensively and after long debate, many flights and several days the designs are ranked in order of their merits (as the judges feel they rate). At least two additional copies of the top rated design are then built and tested thoroughly to insure its suitability. If the additional models perform correctly the model is officially declared the first place winner and the plans are published. If something goes wrong with the test models the cause is traced down to determine whether there was an error in construction or a basic fault in the design.

	Poor	Good	Excellent
How Original?			
Performance?			
Practical To Build?			
Practical To Fly?			
Pleasing Design?			
Neat Plans?			
All Details Clear?			
Complete Instructions?			

When a flaw in the rocket's design shows up the judges go back to debating, test flying, etc. until they have agreed on a new ranking of designs. The outcome of the judging depends on the merits of the designs themselves, and the best models come to the top fairly rapidly.

Since the judges rank among the most experienced model rocketeers in the land, they have little difficulty in separating out the designs which don't measure up to reasonable standards. A rocketeer has the best chance of winning if he tests his model carefully and makes any necessary changes before sending the plans in. And, of course, using the old think box is still the best way to come up with a winner.

What new products, methods and systems we develop next depends largely on the results of the survey included on this issue's wrapper. When we know what you want we can go ahead and try to do something about it. If we don't know, there's not much we can do about it. Even though you consider an item pretty far out, write it down--many of the things that we take for granted today were considered impossible not too long ago.

Knowing your attitude toward model rocketry also helps. If we have a good general idea of what model rocketry means to you we can work towards developing materials which fit better with your special interests. The results of these surveys are a big factor in shaping our programs and policies. The more we know about you, the rocketeer, the more we can do for you.

Rocket Math

THE MATHEMATICS OF PROPULSION

When a rocketeer wants to compare the capabilities of two models or two engines he can approach the problem in any of several ways. He can fly both under controlled conditions and make his comparison on that basis, he can ask another rocketeer for his opinion or he can spend a minute or two calculating some simple performance data before flying or even building and still make a valid comparison.

Three of the most valuable standards for comparing engines and models are impulse, specific impulse and mass ratio. They allow easy comparison of power, engine efficiency and total performance capability.

IMPULSE

The amount of "push" delivered by a rocket engine at any particular moment is known as thrust and is measured in pounds and ounces. The amount of thrust produced by a model rocket engine can be determined using a device like the one shown in fig. 1. If one pound of pressure (or thrust) will move the spring one inch, two pounds two inches, etc., we can measure the line made by the pen to find the greatest amount of thrust produced by the engine. A line 1-7/16" long would then represent 1.44 pounds or 23 ounces of thrust.

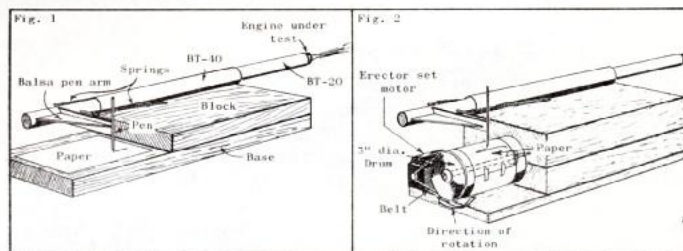

The amount of thrust produced by an engine is important because it determines the engine's weight-lifting ability. Quite obviously an engine with a peak thrust of nine pounds will be able to kick more weight into the air than one with a peak thrust of 1.5 pounds. The more force an engine produces, the greater its ability to boost a load.

If we replace the stationary piece of paper on the test stand of fig. 1 with a strip mounted on a revolving drum as in fig. 2 we can make an additional measurement of thrust--its duration (time). Fig. 3 shows the line a B.8-0P engine would make if the drum turned at one inch per second.

Immediately we see that the engine's thrust is not constant. Instead it rises to an initial peak of 23 ounces; then drops to a sustaining level of 12 ounces. To find the total amount of power, or total impulse, produced by the engine we lay a grid over the thrust-time curve as in fig. 4. Each square on the grid is 0.1 pound times 0.1 second or 0.01 lb. sec. of impulse. By counting the number of squares inside the curve we find the total impulse. (A square that is more than one half inside the line counts as a

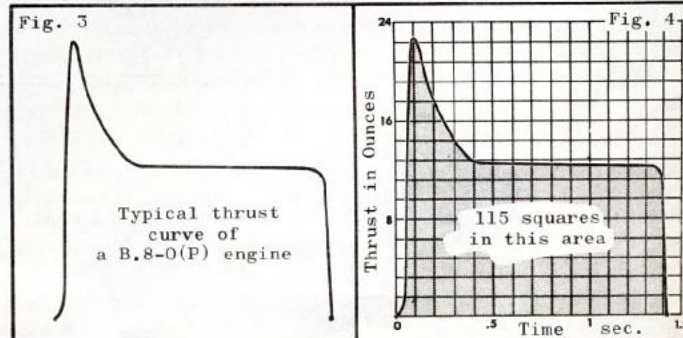

whole square; those less than half inside are not counted. This system produces an accurate average.) There are 115 squares inside the curve in fig. 4 so we multiply 115 times 0.01 lb. sec. and find that the engine produced 1.15 lb. sec. total impulse.

The basic formula for total impulse is:

$I = F \times t$ Where: I = total impulse
 F = average thrust
 t = duration of thrust (time)

An engine that delivers a constant 1 pound of thrust for 1 second has the same total impulse as an engine that produces 10 pounds of thrust for 0.1 second--one pound second for each.

The formula for total impulse can be turned around to find average thrust. It will then become $F = \frac{I}{t}$. Since the B.8-0P

in fig. 4 produced 1.15 pound seconds impulse in 1.4 seconds, we divide 1.15 by 1.4 and find that the average thrust is 0.821 pounds. For practice determine the total impulse and average thrust of the engine whose thrust-time curve is shown in fig. 5. (Answers 1 and 2 at end of article.)

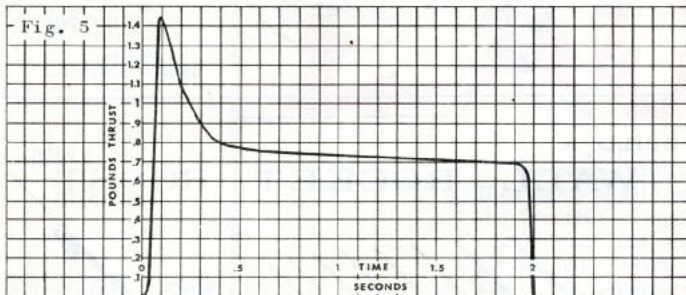

If all other conditions are equal a rocket with more total impulse will go farther and faster than one with less. As a result we can expect a rocket to go higher with a B engine than with an A engine. Similarly an engine with high average thrust can lift more weight off the pad satisfactorily than one with low average thrust. By applying this knowledge to the data in the engine selection chart it is easy to choose the best engine for any set of conditions.

SPECIFIC IMPULSE

The efficiency of a rocket engine or propellant is described by specific impulse. This figure is the number of pound seconds total impulse one pound of propellant would deliver. While we could try building an engine around a pound of propellant and then measuring the total impulse, there is an easier, safer way to find specific impulse. The formula for this is:

$I_{sp} = \frac{I}{W_p}$ Where: I_{sp} = specific impulse
 I = total impulse (in pound seconds)
 W_p = weight of propellant (in pounds)

Table One shows propellant weights for the Estes engines in Series I, II and III. Continuing with the B.8-0P engine we divide its total impulse (1.15 pound seconds) by its propellant weight (0.0139 pounds) to find its specific impulse--83 pound seconds per pound (abbreviated as "83 seconds"). Using this formula, what is the specific impulse of an engine which develops 1.4 lb. sec. total impulse from 0.02 pounds of propellant? (Answer 3 at end of article.)

TABLE 1

Engine Type	Propellant Weight	Total Impulse	Thrust Duration	Average Thrust
C	0.0181 lb.	1.50 lb. sec.	2.00 sec.	0.75 lb.
B Series I	0.0139 lb.	1.15 lb. sec.	1.40 sec.	0.82 lb.
B Series II	0.0139 lb.	1.15 lb. sec.	0.35 sec.	3.30 lb.
A	0.00844 lb.	0.70 lb. sec.	0.90 sec.	0.85 lb.
1/2A	0.00422 lb.	0.35 lb. sec.	0.40 sec.	0.87 lb.
1/4A	0.00211 lb.	0.17 lb. sec.	0.17 sec.	1.00 lb.

While the specific impulse of all present Estes model rocket engines is practically the same it is useful to be aware of the effect of specific impulse on rocket flight. If two rockets of identical size, shape, weight and propellant weight were tested and it was found that one had a specific impulse of 50 seconds and the other 100 seconds we would know immediately that the one with the greater specific impulse would be twice as efficient as the other and would perform correspondingly. Fig. 6 illustrates the effect of specific impulse.

An engine's specific impulse is also used to estimate the velocity of its exhaust gases. The formula for exhaust velocity is:

$c = g \times I_{sp}$

Where: c = exhaust velocity
 g = acceleration of gravity (32 ft. per sec. per sec.)
 I_{sp} = Specific Impulse

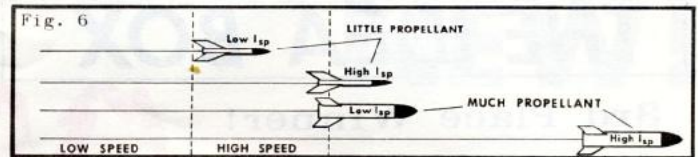

With our B.8-0P engine we multiply the acceleration of gravity (32) by the specific impulse and find that the engine's exhaust velocity is approximately 2656 feet per second.

Exhaust velocity helps explain why an engine with a high specific impulse is more efficient than an engine with low specific impulse. According to Newton's third law, "For every action there is an equal and opposite reaction." There is more "action" to a molecule of gas leaving the nozzle at 2500 feet per second than to the same molecule leaving at only 1000 feet per second. Thus the fast-moving molecule also produces more "reaction."

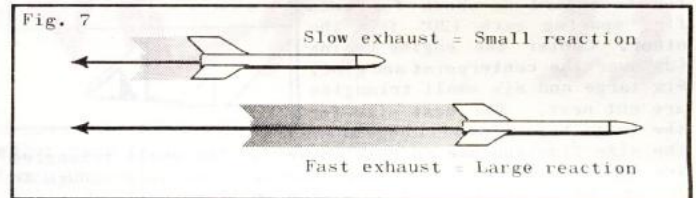

MASS RATIO

The relationship between the takeoff weight of a rocket and the weight of the rocket after the propellant has been expended is known as the mass ratio. This is expressed as a number obtained by dividing the initial weight of the rocket by its burn-out weight. Mathematically we find that:

$n = \frac{W_i}{W_i - W_p}$ Where: n = mass ratio
 W_i = initial rocket weight
 W_p = propellant weight

If all other conditions are identical, a rocket with a high mass ratio will reach a greater velocity than one with a low mass ratio because a greater percentage of the rocket with the high mass ratio is propellant. Using the mass ratio it is easy to compare the potential performance of a rocket under various payload and engine size conditions.

It is quite possible to build a single stage payload rocket that weighs only 0.4 ounce without engine. Using a 1/2A.8-2S engine in the rocket and no payload would result in a mass ratio of 1.10. However, an A.8-3 engine and a one ounce payload weight would give the rocket a mass ratio of only 1.07. The rocket offers greater potential performance with the smaller engine and no payload. With a B.8-4 engine and a one ounce payload the same rocket would have an initial weight of 2.11 ounces. What would its mass ratio be? (Answer 4 at end of article.)

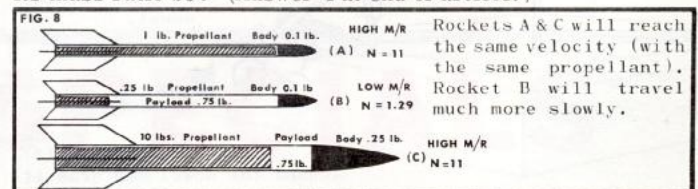

In practice the rocketeer can generally expect a rocket with a higher mass ratio to go higher than a rocket with a lower one. If it doesn't, there is probably something wrong with the design of the model which should be corrected to get top performance. Quite often poor performance is caused by poor aerodynamic design. Careful attention to reducing the frontal area of the model, sanding and painting it will do much to improve it.

One mark of the true scientist is the complete and accurate records he keeps. By keeping accurate records of the performance data for various rockets, including preflight calculations and altitude attained, the rocketeer can build up a valuable store of information on the effects of different conditions on rocket flight. These records can often prove especially useful as the raw material for science projects and can serve as guidelines for designing and building better rockets.

ANSWERS

- 1) 1.5 lb. sec. total impulse 3) 70 pound seconds per pound
 2) 0.75 pounds average thrust 4) 1.12 mass ratio

THE IDEA BOX

3rd Place Winner!

H.G. Hermann, of Columbus, Ohio sent this handy tool idea. The E-Z FIN SPACER can become a permanent part of your tool kit and is made from things you'll have on hand or can easily get.

The drawing is for a three fin guide but four fins can be aligned by marking the base of the spacer at 90° angles instead of the 120° angles shown for the three fin unit.

Draw a line from the center of the baseboard as shown for each fin, spacing each 120° from the other. Center the engine casing (2) over the centerpoint and glue. Six large and six small triangles are cut next. The best size for the large triangles will depend on the size fins you use on your rockets. The small triangles are supports for the large ones so make them big enough to do the job. Cut accurately as the small triangles support the larger ones at a perfect 90° and insure accurate fin positioning. Spacing the guides at least 1/4" (3) away from the engine casing will let you use the guide for a variety of body tube sizes.

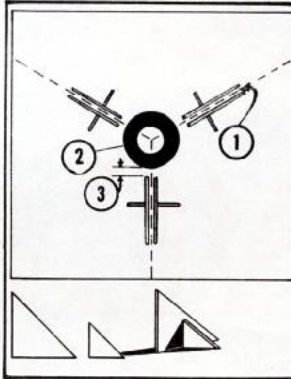

MODEL "GANTRY" PROVES USEFUL

To get the clips out of the way of the tail on your front engine boost-glider try this idea. Use it as an addition to your present pad or build a second special purpose launcher.

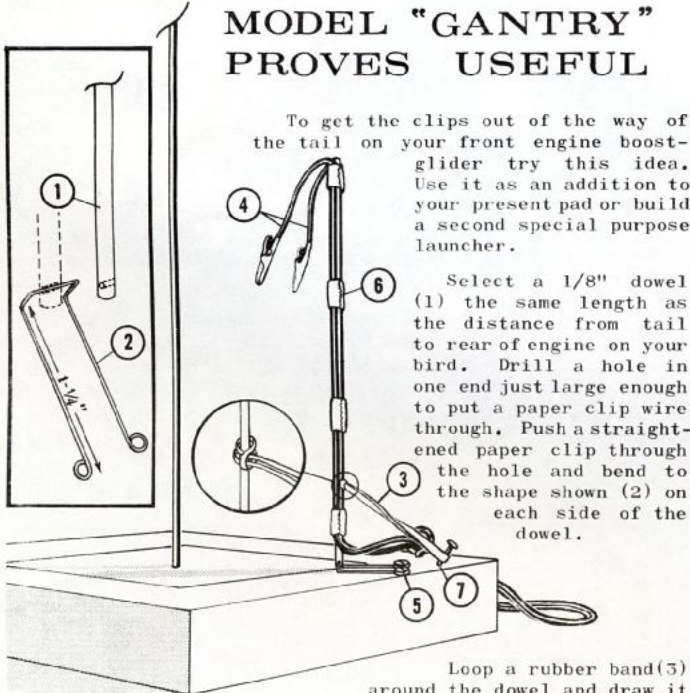

Select a 1/8" dowel (1) the same length as the distance from tail to rear of engine on your bird. Drill a hole in one end just large enough to put a paper clip wire through. Push a straightened paper clip through the hole and bend to the shape shown (2) on each side of the dowel.

Loop a rubber band (5) around the dowel and draw it snug. Cut the proper length leads, allowing 2" loose wire at the top (4) and enough for battery and switch connections at the other end. Place your bird in position on the pad and select the best position for the "gantry". Use a pair of small wood screws to mount it (5). Attach micro clips to the leads and tape the leads to the rod (6) at two to three inch intervals. How quickly the clips get away from the engine depends on the tension on the rubber band. Find the proper tension for rapid action and drive a small nail into the block to anchor the rubber band (7).

INSULATE YOUR IGNITERS

To keep nichrome igniters from shorting out and misfiring, insulate them with butyrate dope. Bend a normal length of nichrome in half (1) and dip into dope leaving a 1/2" "pigtail" on each end as shown (2). After second dip has dried form loop (3) and stow in field kit.

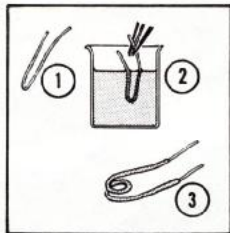

ENGINE BLOCKS "STAY PUT"

Balsa or paper engine blocks will stay where you install them if you first bevel the edge that enters the tube first. Besides making it easier to start the block into the tube, the bevel acts as a scoop to insure a layer of glue between the block and tube wall. Glue will also pile up ahead of the block and so the block makes its own fillet as it is positioned. Be careful you do not stop once you start to insert the block into place.

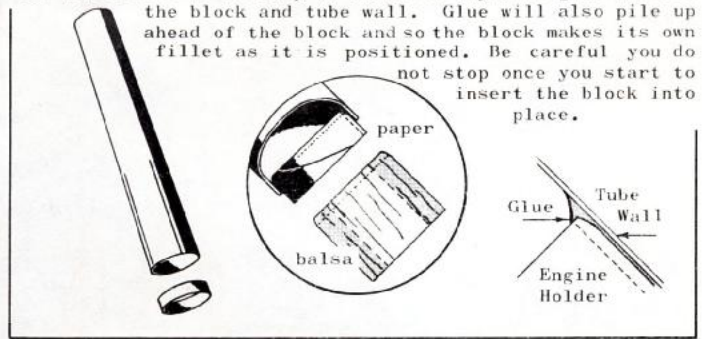

BUILD A WALL ROCKET ROOST

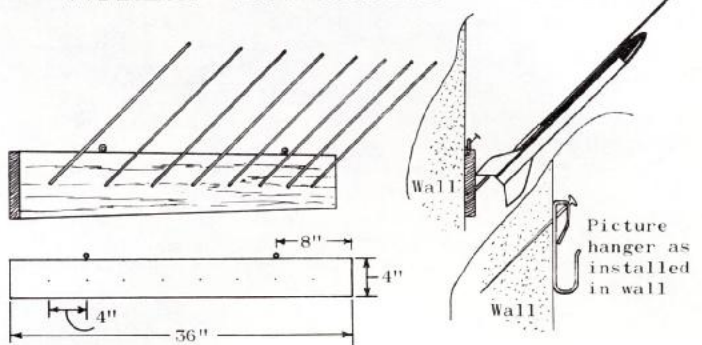

Build a combined display and storage rack for your birds that is both practical and good looking. Materials required are 8 1/8" (WD-1) dowels, 2 (SE-2) screw eyes, 1"x4"x36" pine board, sandpaper and paint or varnish.

Sand all edges and one face of the board. Drill 1/8" holes 4" apart starting 4" from the left edge and 2" from the bottom edge of the board, drilling at a 45° angle. Coat 1/2" of one end of a full length dowel with glue and insert into a hole. Continue this action with the remaining dowels. Install the screw eyes 8" in from each end along the top edge of the board and apply paint or varnish to the entire structure.

When dry, mount the rack on the wall at the desired level with nails or standard picture hangers.

An Answer to a Sticky Problem...

A "frozen engine" need never be a problem if you use this idea sent in by Robert C. Colabella, of Bordentown, N.J.

An ordinary inch or inch-and-a-quarter wood screw in the field kit will help you pull those really stubborn engines.



6th Place Winner!

Don't use with live engine!

Winners of the 1963 Idea Box Contest

Estes Industries Rocket Plan No. 26

Sly Bolt

Easy to Build Sport Bird

Published as a service to its customers by Estes Industries, Inc., Box 227, Penrose, Colorado. ©Estes Industries 1964

BUILDING

The Sly Bolt rocket is a companion piece to the feature article on pages 1 and 2 of this issue of the Model Rocket News. The construction procedures set forth in that article should be referred to as you proceed to build this rocket.

Note that the Sly Bolt uses an engine holder (EH-2) rather than an engine block for easy engine changing and that its body tube is of sturdy BT-50 for a long lasting bird which will turn in many fine flights.

Parts List

1	Body Tube	BT-50
1	Nose Cone	BNC-50M
1	Engine Holder	EH-2
1	Screw Eye	SE-1
1	Shock Cord	SC-1
1	Parachute Kit	PK-12
1	Launching Lug	LL-1B
1	Sheet Fin Stock	BFS-20

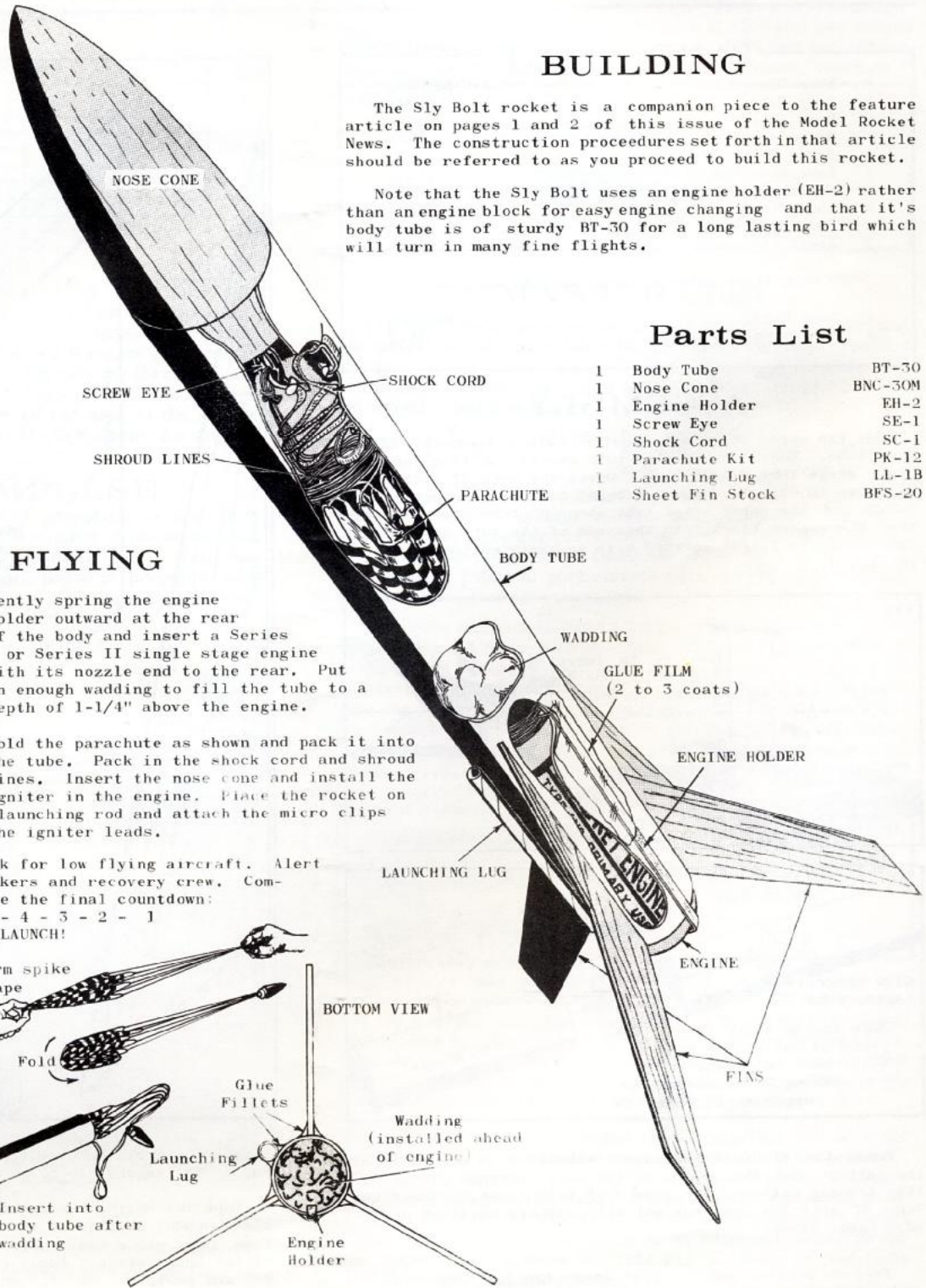
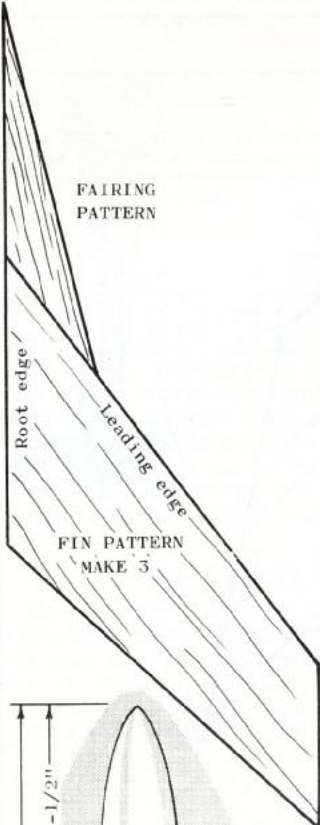

FLYING

Gently spring the engine holder outward at the rear of the body and insert a Series I or Series II single stage engine with its nozzle end to the rear. Put in enough wadding to fill the tube to a depth of 1-1/4" above the engine.

Fold the parachute as shown and pack it into the tube. Pack in the shock cord and shroud lines. Insert the nose cone and install the igniter in the engine. Place the rocket on the launching rod and attach the micro clips to the igniter leads.

Check for low flying aircraft. Alert trackers and recovery crew. Commence the final countdown:
 - 5 - 4 - 3 - 2 - 1
 LAUNCH!

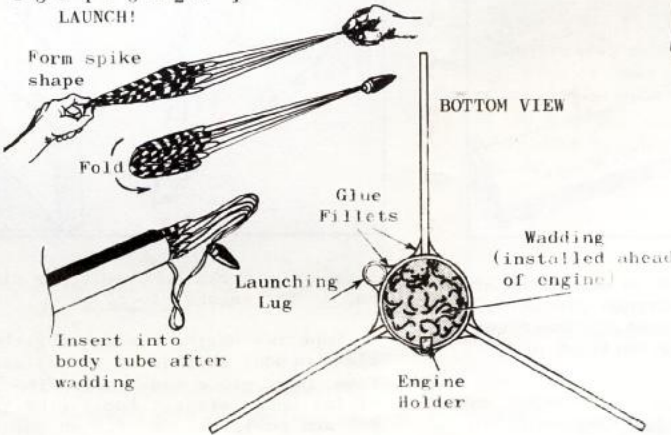
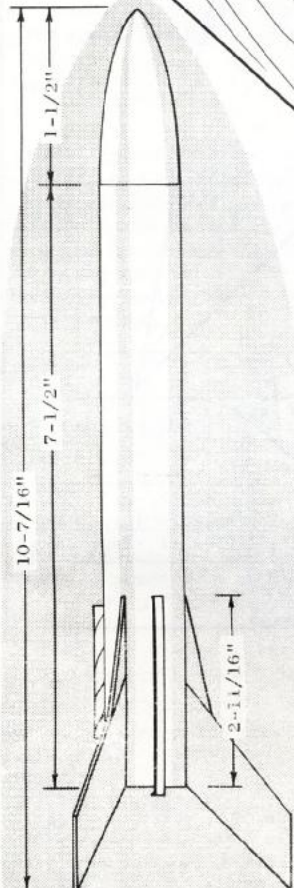

Estes Industries Rocket Plan No. 27

DEACON

FIRST PLACE WINNER! '64 MULTI-STAGE CONTEST

Design by Ronald Tessendorf

Published as a service to its customers by Estes Industries, Inc., Box 227, Penrose, Colorado

PARTS LIST

1	Nose Cone	BNC-50K
1	Body Tube	BT-50S
1	Body Tube	BT-20
1	Balsa Adapter	TA-2050
1	Screw Eye	SE-2
1	Launching Lug	LL-1C
1	Engine Block	EB-20
1	Shock Cord	SC-1
2	Parachute Kits	PK-12
3	Sheet Fin Stock	BFS-20

When flown without large payload section

1	Nose Cone	BNC-20N
1	Screw Eye	SE-2

ASSEMBLY

Cut the upper stage and booster bodies from the BT-20 body tube. Make the booster tube exactly 3" long and the upper stage tube 9-1/2" long. Dress the ends of each piece as shown in Fig. 1. Smear a liberal coat of glue around the inside of the upper stage tube about 2" from one end. Insert the engine block into this end of the tube and push it into position 2-1/4" forward with an empty engine casing as in Fig. 2.

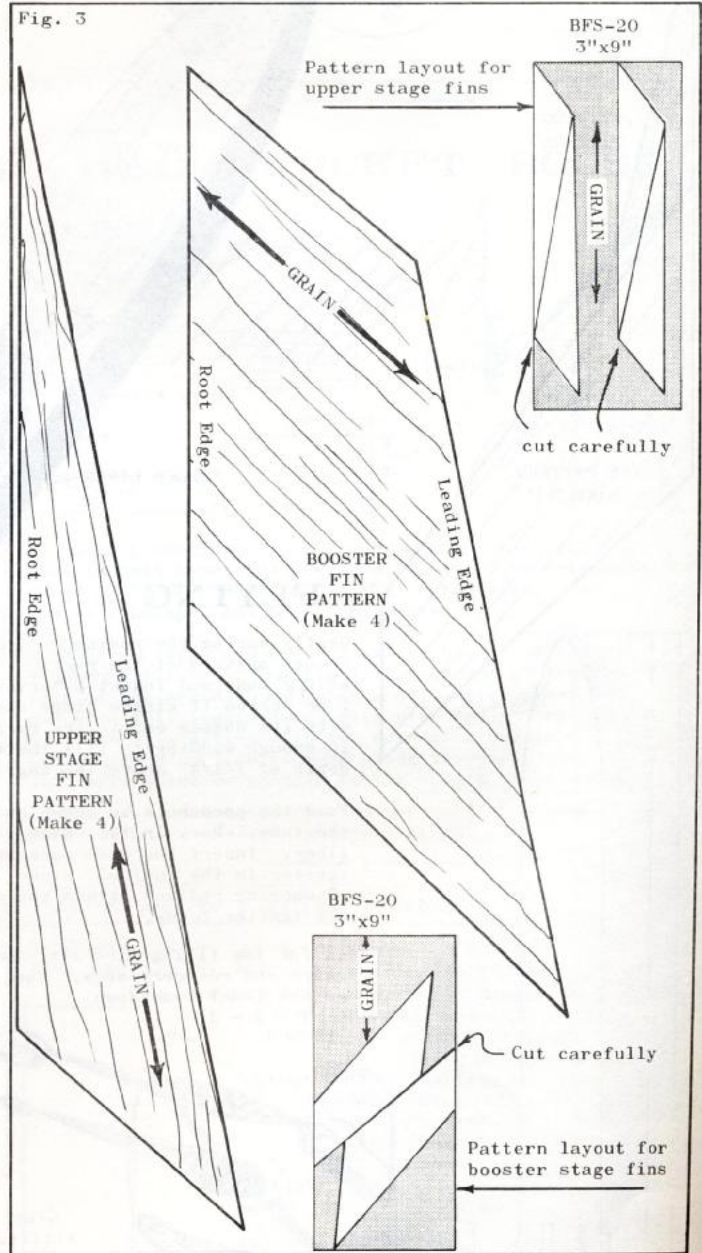
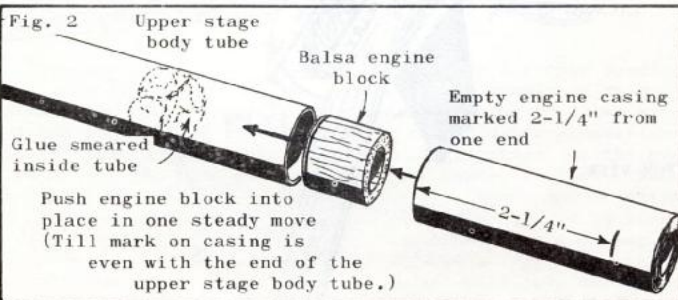
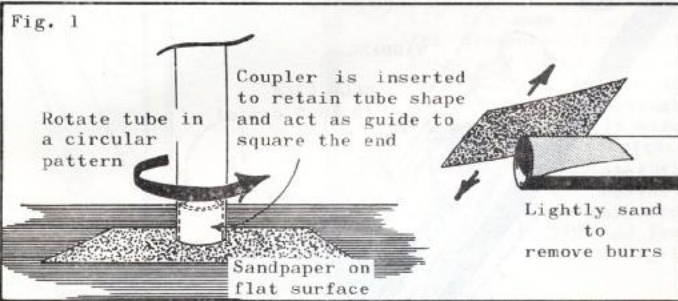

Trace the fin patterns onto the balsa with the grain of the pattern and the grain of the balsa aligned perfectly. (For tracing methods, see page 2 of this issue.) Trace out four of each fin and cut out with a sharp knife or single edge razor blade.

Tape one booster and one upper stage fin together as shown and carefully sand until rounded, all exposed edges except the root edge. Sand the root edge flat. Repeat with the other sets (see Fig. 4). Make a fin marking guide as shown in Fig. 4B and mark both the booster and upper stage bodies for four

fins. The marks on the upper stage should be at the same end as the engine block.

Tape two engine casings together with cellophane tape and place in body section in normal position. Slide the booster tube into place and line up the fin guide lines with those of the upper stage. Apply glue to the root edge of one fin set and position one fin on one side of a guide line as in Fig. 5. Attach the other three fin sets in place in the same manner, making sure that each set is on the same side of the guide line. Be sure all fins protrude straight out from the body tube. set the rocket aside to dry, but do not

set it on its fins. (For best results support the rocket in a vertical position.)

Glue the balsa adapter in one end of the payload section (BT-50S) and check the fit of the nose cone BNC-50K in the other end. Tape or sand the shoulder of the nose cone until it is a firm fit into the payload tube. A slight taper as shown in Fig. 6 will make the nose cone easier to insert. Sand the adapter and nose cone with fine sandpaper and apply the first coat of sanding sealer to both. During this part of the work protect the shoulder of the adapter with a scrap piece of BT-20. Leave the scrap in place while sanding and applying sealer.

Before separating the upper stage and booster, draw a line parallel to the root edge of one fin set exactly $5/32$ " from the root edge. Cut the launching lug LL-1C into three pieces as shown in Fig. 7A. Install two of these pieces as shown in Fig. 7B. If the fins have been glued carefully, removal of the tape may be all that is needed to separate the upper stage from the booster. If a film of glue has bridged the tube separation point, carefully insert a knife blade between the fins near the root edge and cut this film. The booster and engine casings may now be easily separated from the upper stage.

Install the screw eye in the center of the adapter base as in Fig. 8. Remove the screw eye, squirt glue into the hole and replace the screw eye. Install the third piece of the launching lug (see Fig. 7A) on the payload tube with the rear of the lug even with the tube-adapter joint. Align it carefully to parallel the centerline of the section.

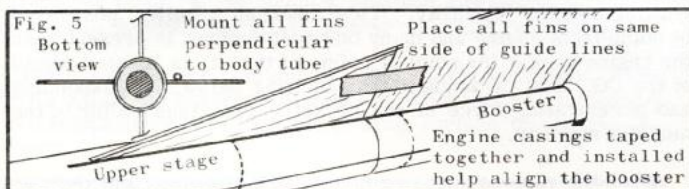
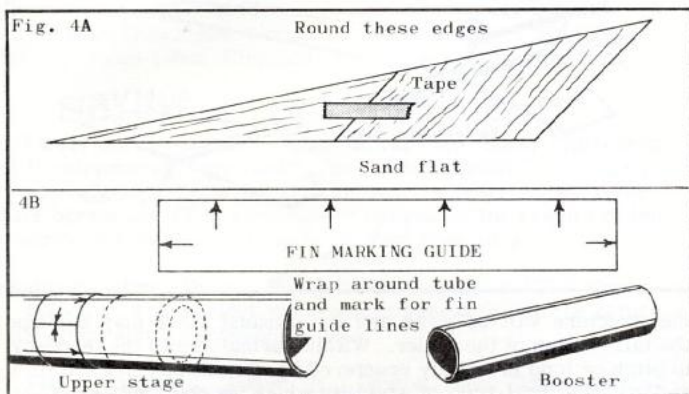

Recovery System

Drill a small hole $1/2$ " from the trailing edge of the fin opposite the one on which the launching lug is mounted. Thread one end of the static line (a 10" piece of shroud line) through this and make a large knot. Secure the other end of the static line to the shock cord. Make a small loop in the free end of the shock cord as in Fig. 9. Cut a $1/2$ " long by $1/32$ " wide slit in the upper end of the body directly above the fin with the hole, to admit the static line.

Cut out the parachutes and attach the shroud lines. Tie one set of lines to the payload section screw eye. Tie the other chute lines to the shock cord loop and your bird is ready for final assembly and painting.

Painting

Sand, seal and paint your model as described on page two of this issue.

Launching

Follow the procedures described in Technical Report No. TR-2.

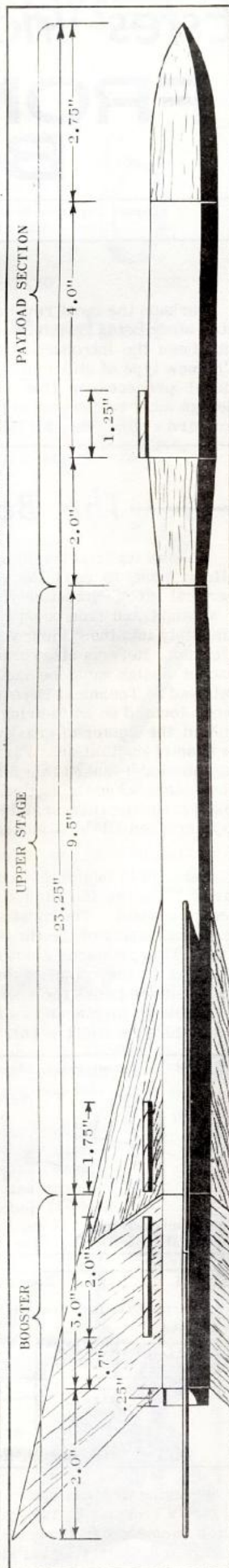
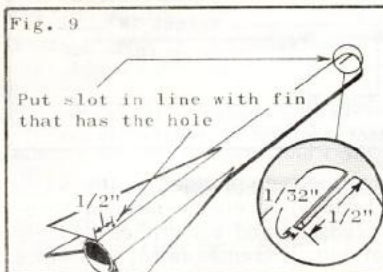
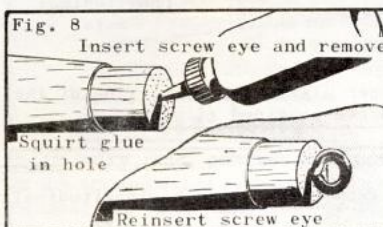
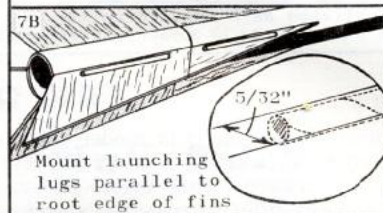
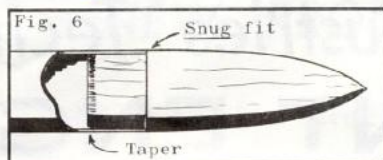

Estes Industries Technical Report No. TR-7

FRONT ENGINE BOOST GLIDERS

By
Gordon Mandell

These reports are published as a service to its customers by Estes Industries, Inc., Box 227, Penrose, Colorado
Copyright 1964 by Estes Industries, Inc.

Introduction

Perhaps the most revolutionary development in model rocketry since Estes Industries created the first boost-glider in 1961 has been the introduction of the forward engine boost-glider. The new type of glider is so radically different from its conventional predecessor that many formerly accepted ideas about design must be changed to fit the special cases encountered in forward engine design if the best configuration is to be achieved.

This report contains the findings of a research program conducted since June, 1963, which succeeded in determining the requirements for good forward engine design. As flight testing was the major research method, many criteria are qualitative, but due to the fine tolerance demanded in forward-engine design the uncertainty in quantitative data is only plus or minus 5%.

The Boost Phase

Despite its airplane-like appearance the front engine boost-glider must, to meet the definition of its type, be capable of a vertical liftoff without relying on lifting surfaces. It must have a straight and true boost trajectory and must enter quickly and smoothly into the gliding recovery phase of flight after engine ejection. Here as elsewhere conflicting demands of aircraft and rocket design must be met to obtain a workable vehicle. As detailed in Technical Report TR-4 the glider must have its surfaces located so as to bring the center of pressure far enough behind the center of gravity to produce enough corrective force in case of oscillation. Fortunately the arrangement of the front engine model makes this fairly easy since weight is concentrated in the nose when the engine is in place. In building and flight testing nearly fifty vehicles not a single case of instability due to misplaced CP location was encountered.

This aid to design is countered by several undesirable features including the high degree of asymmetry of most forward engine models. The most serious of the results of asymmetry is the offsetting of the thrust line from the CG along the vertical axis. This produces a down-pitching effect whose moment-arm is equal to the offset distance and whose magnitude is equal to this distance times the engine's thrust (figs. 2 and 3). If the CP is similarly displaced, as it often is, the resulting pitching will also affect the flight. This effect, however, is normally small.

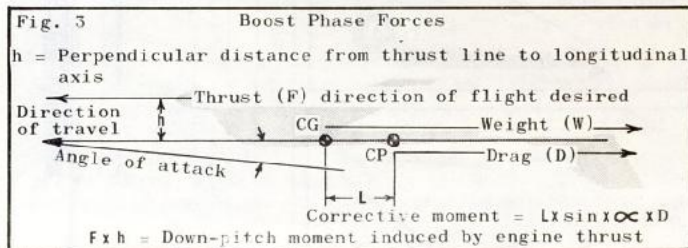
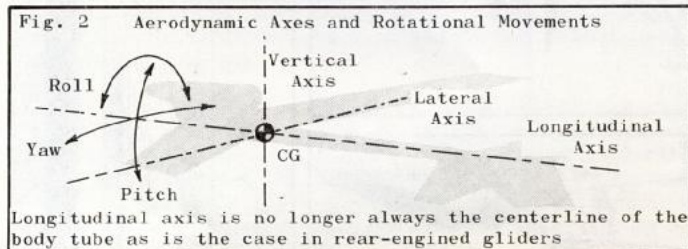

By using low pylons and large amounts of dihedral (the angle of the "V" formed by two-panel wings) the engine-induced down-pitch moment can be greatly reduced and sometimes entirely eliminated. Carrying the practice to extremes is not wise since

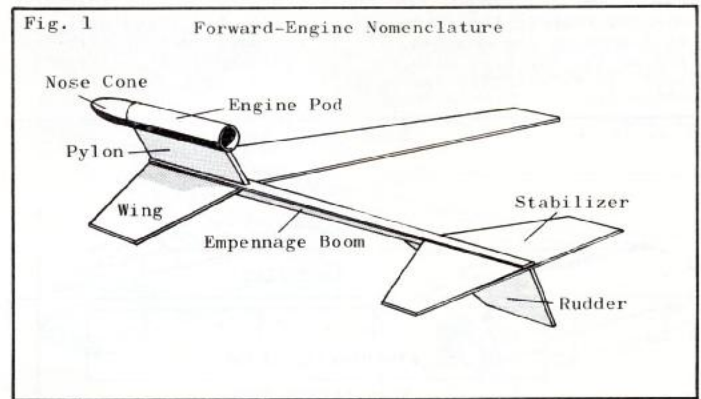

the structure will be weak and the exhaust blast may damage the tail section of the glider. Within normal limits the tendency to pitch or loop is readily countered by normal positive stability and an additional type of stability which we shall call stick, or trailing member, stability. This inherent stability, possessed by some front engine and many odd-ball designs, is present when the engine nozzle (or point of origin of thrust) is located ahead of the CG. The CG tends to trail or hang below the suspending and accelerating force of the rocket engine, thus adding to the model's stability.

When the various opposing factors are combined and the results analyzed by flight testing we find that minimum stability for front engine boost-glidiers is about 3/4 body diameter.

The Glide Phase

The big advantage of the front engine boost-glider lies in its method of attaining and maintaining a gliding attitude following engine ejection. Although a number of front engine designs use ailerons and other high-lift devices to increase the lift/drag ratio, the basic front engine configuration has no moving parts. It relies solely on the shift of the CG and the loss of weight that accompanies ejection to initiate the recovery phase, and so can be more reliable than many conventional designs.

There are two major methods of designing the glider to automatically initiate glide. One is the addition of negative incidence to the horizontal stabilizer, i.e., placing a small shim of balsa under the stabilizer trailing edge so that the stabilizer forms a slight negative angle with the empennage boom. This angle, never exceeding one degree, makes possible the use of very thin wings, and even wings with no airfoil at all. Its disadvantage is that it often produces poor boost characteristics, especially a nose-up pitching moment which greatly reduces altitude and occasionally results in loops and crashes. An extremely del-

icate balance must be maintained between the nose-down engine moment and the nose-up stabilizer moment, a balance far more critical than that commonly found in free-flight model airplanes. Such a condition can not be easily produced, and once produced, can not be reliably duplicated. It is thus unacceptable for general use.

been found that thin, flat-bottomed sections with a maximum thickness of seven to ten percent of the wing chord (the distance from the leading to the trailing edge) and with the maximum thickness between 25% and 35% back on the wing are satisfactory. Little work has been done with airfoils other than flat-bottomed, but experience to date indicates that the range of available types is quite broad.

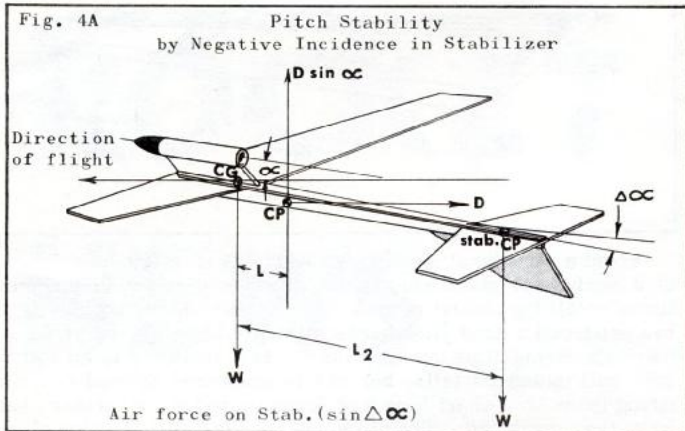

A second method which largely solves the problems encountered with the first is the use of an airfoiled wing. The wing airfoil operates on a principle discovered by the Swiss physicist Daniel Bernoulli, producing a lifting force even when held at zero angle of attack to the relative airstream. Bernoulli found that when air moves rapidly its pressure decreases. The upper side of the wing, being more highly curved than the often flat and sometimes undercambered lower side, forces the air to move more rapidly around it. This produces a low-pressure area directly above the wing into which the wing is forced by the relatively high pressure below it. Since such a wing may be mounted at zero angle of attack and since it "stalls," or loses lift, when at a high angle of attack, it produces little pitch-up moment in boost phase, allowing a smoother vertical flight while producing a superior glide.

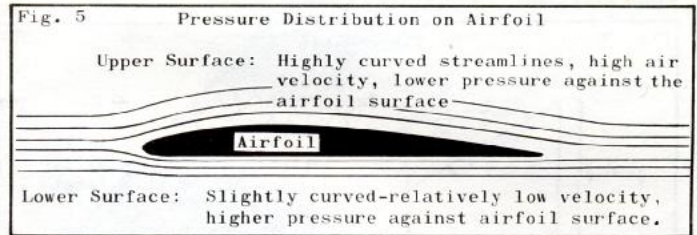

The proportions and areas of the various parts of a forward engine boost-glider and their relations to each other have great effect on its performance. For instance, front engine boost-glide designs operate best with a wing area between 20 and 40 square inches. Less area results in high wing loadings and a rapid descent, while more area results in excessive drag and susceptibility to warping. The balsa empennage boom must not be too short, or a loss of stability results, while too much length adds weight. The best length is between 0.9 and 1.1 times the wing span. The area of the horizontal stabilizer should not fall below 30% of the wing area when zero-incidence airfoiled wings are used, but areas over 40% add excessive weight and drag. The rudder area, including stabilizer tip plates (if any) should generally be between 8% and 15% of the wing area, since less area results in loss of control and more in unnecessary drag. As the rudder is normally below the empennage boom to avoid the exhaust gases, a large one will also reduce roll stability and may result in spiral diving. There is a wide range of usable dihedral angles for wings. Values between 0° and 28° have been used successfully. Best results come between 4° and 16°. In this range the dihedral does its job of increasing roll stability without any shortcoming.

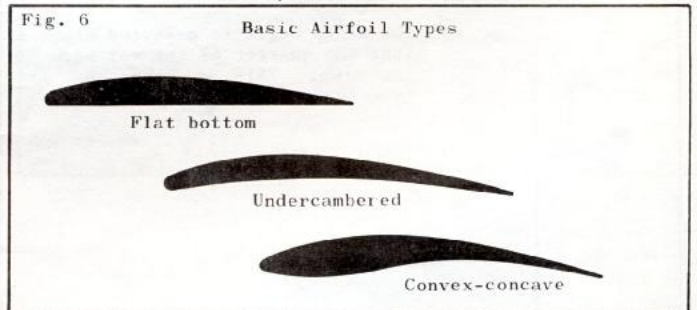
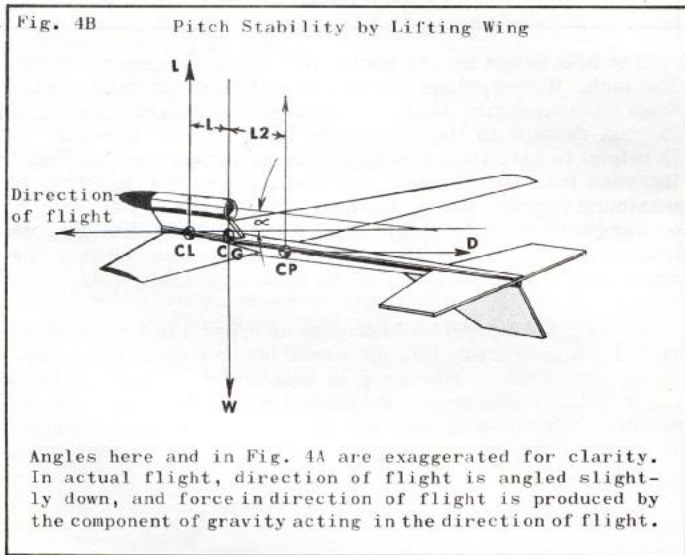

Front engine gliders can usually use higher aspect ratios than rear engine models (normally up to 4.5) with the upper limit imposed by structural requirements. Taper ratio (fig. 8) should be between 0.3 and 0.6. Lower ratios reduce roll stability and higher ones are subject to structural limitations. There is a wide variation allowable in the selection of sweep angle. Successful models have been built with sweeps from 15° to 55°, but the best compromise between structural and aerodynamic requirements lies between 40° and 45°. The sweep of the wing (within certain limits) increases the effectiveness of dihedral.

Airfoil Shape

There are many airfoil shapes, some more efficient than others. The boost-glider is an unusual case of very small size and low velocity (when gliding), both of which tend to make the Reynolds Number quite small. Boost-glider Reynolds Numbers range from 25,000 to 100,000 in most cases, while those for full size aircraft are well up in the millions. A full discussion of Reynolds Numbers is not in order here, and may be found in most aerodynamics texts if further information is desired. The important effect, however, is that airfoils suited for larger and faster vehicles are relatively poor on the boost-glider. It has

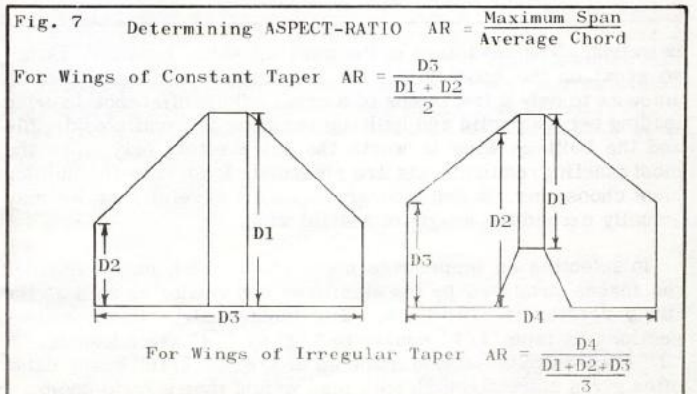

A final item to consider with forward engine designs is wing loading. This is the factor which, along with the high lift/drag ratio, helps explain the superior performance of a well-designed front engine glider. The average loading for a forward engine model is between 0.17 and 0.3 pounds per square foot as compared with 0.25 to 0.7 for most rear engine designs. Loadings higher than these result in rapid descent and short duration, while lower ones raise doubts as to structural strength.

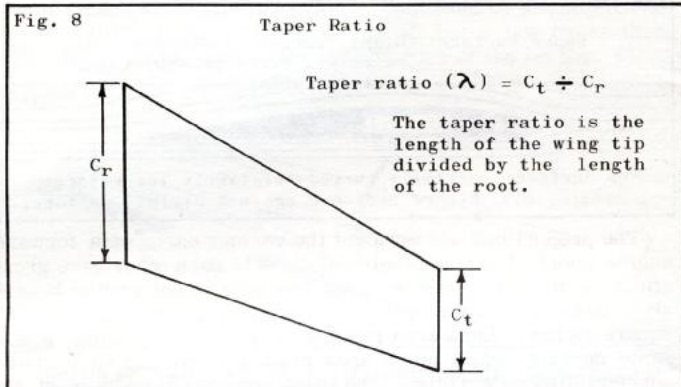

— Structural Considerations —

Structural considerations as limiting factors for aspect ratio, wing loading, etc. have already been discussed. Some other criteria peculiar to front engine designs also deserve mention, including wing structure. There are two basic types of wing construction: solid and built-up. The first is the common sheet blasa wing with a sanded-in airfoil and the second is a framework of ribs and spars with a covering of silk or treated paper such as "silkspar." In large model airplanes the built-up wing is used almost exclusively since it offers a considerable saving

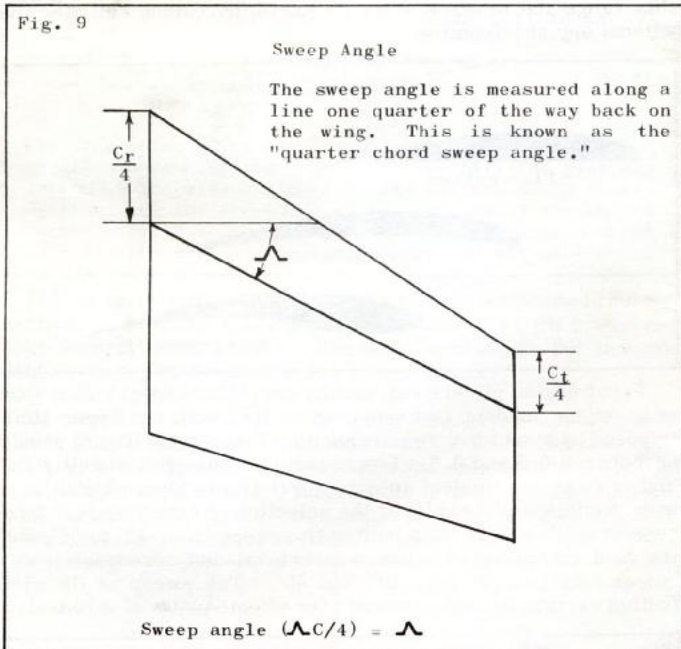

in weight. The advantage of the built-up wing, however, is not so great on the boost-glider as the actual weight saving often amounts to only a few tenths of a gram. The difference in wing loading between solid and built-up versions is usually negligible and the built-up wing is worth the extra effort only when the most exacting requirements are enforced. Even here the builder must choose his rib and spar arrangement carefully or he may actually exceed the weight of a solid wing.

In selecting an empennage boom the builder must consider the forces produced by the stabilizer and rudder as well as the likely accelerative loadings. For most models boom cross-sections of from 1/4" square to 1/4" by 1/2" are adequate. A "T" shaped cross-section made up of 1/8" or 1/16" sheet balsa often gives more strength with less weight than a solid boom.

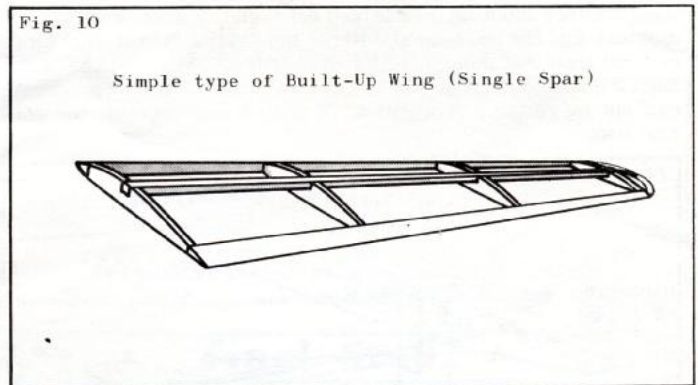

From a structural standpoint the standard tail configuration of a horizontal stabilizer with a single subrudder (and sometimes small tip plates) is best. A "V" shaped, or butterfly, tail has produced a good glide but is more apt to break and tends to catch the firing clips during launch. This tendency is also present with standard tails, but can be combated by mounting the firing leads on a short length of dowel or rod about three inches from the launch rod. The clips will then fall to a position along the "gantry" rod rather than vertically along the launch rod.

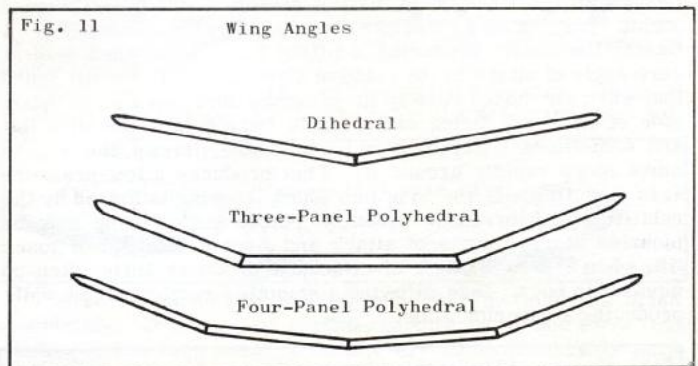

The best height for the engine pod pylon is approximately a half inch. Higher pylons are weaker and result in greater nose-down moment during boost. Lower pylons generally result in exhaust damage to the empennage boom and tail structure. It is helpful to have the pylon angled as far forward as possible to increase both aerodynamic and trailing-member stability; the maximum forward sweep, however, is limited to an angle of 15° or more with the longitudinal axis. Less angle results in engine damage to the pylon trailing edge and often in a noseheavy configuration. Pylon angles of 30° to 45° are generally best.

Structural strength could impose an upper limit on wing dihedral, but in practice this limit need not be considered as maximum aerodynamic efficiency is reached at a point well below the structural maximum. Polyhedral wings, however, will encounter difficulties if they are not sufficiently thick to resist warping caused by accelerative and aerodynamic loads on the wingtips.

— Flying Practice —

Front engine boost-gliders have been multi-staged with some success, the booster stage simply consisting of a length of body tube. However, stability is reduced, the stages are difficult to retrieve undamaged, and the larger, multi-staged gliders often give shorter duration than small, light single stage vehicles.

One last structural requirement arises when it is not desirable to allow the engine to fall free following ejection. This requirement can be met by constructing the engine pod from a larger diameter body tube than is a glove-fit for the engine and taking up the added diameter with streamer material taped on the engine. A six to eight inch streamer may thus be used on the engine casing and will unroll from the engine after ejection.



ELECTRO-

NEW!

LAUNCH II

Adjustable
Launch Angle

Safety
Interlock

Continuity Check
Light

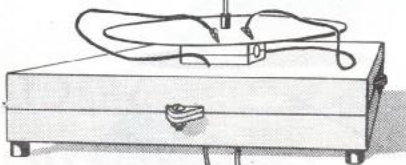

The biggest little launcher in the world! The Electro-Launch II brings you all the features that made the old Electro-Launch the favorite of model rocketeers around the world, plus all new convenience and versatility never before available. High impact plastic base, extra-large blast deflector, easy-to-adjust launch angle and collapsible two-piece 36" launch rod make the pad unit the best ever. Add a control panel that features a safety interlock to prevent accidental launchings, combination arm and continuity check light to eliminate misfirings and push-button ignition control and you have the ultimate model rocket launcher! Use it for rockets weighing up to 6 oz., or anchor the base to the ground for heavier models. Requires 4 size D photoflash batteries for 6 volt operation, gives long battery life. Easily converted to 12 volts for extra heavy-duty use, requires only 4 more batteries and a 12 volt pilot bulb to make the change. In easy-to-assemble kit form, complete with all parts and instructions (but no batteries). Shipping weight 30 oz.

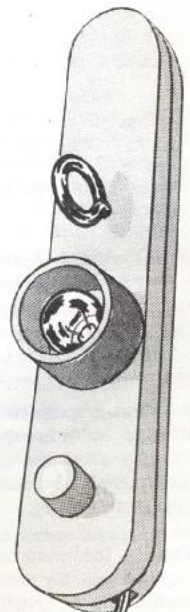

Cat. No. 641-FS-1A

\$3.00 p.p.

The same kit as above and complete with 4 batteries:

Cat. No. 641-FS-1C Shipping weight 46 oz. **\$4.00 p.p.**

STARTER SPECIALS

\$6.00

Beginners Special

The complete outfit for getting started in model rocketry. Contains:

1 WAC CORPORAL KIT	#K-11
1 DESIGN BOOKLET	#P-1
1 ENGINE	#1/2A. 8-2
1 ENGINE	#A. 8-3
1 ELECTRO-LAUNCH II	#FS-1A
4 BATTERIES	#PFB-1

Shipping weight 3 lb.

Cat. No. 641-SK-6C \$6.00 each p.p.

Start your friends out in model rocketry with these great new Beginners Specials. Easy-to-build WAC Corporal kit gets them going in scale modeling and parachute recovery right from the first. Design booklet gives up-to-date, authoritative information on model rocketry.

**Great
for Christmas
Giving**

\$2.00

Beginners Special

Recommended for those who have access to an electrical launching system or can build their own. Contains:

1 WAC CORPORAL KIT	#K-11
1 DESIGN BOOKLET	#P-1
1 ENGINE	#1/2A. 8-2
1 ENGINE	#A. 8-3

Shipping weight 12 oz.

Cat. No. 641-SK-2 \$2.00 each p.p.

THE CAMROC

Rocket Camera

EXCITING NEW BREAKTHROUGH!

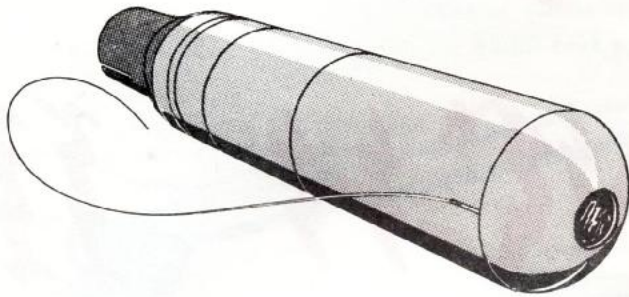

The Camroc opens an entire new field for the model rocketeer. Now you can study space-age reconnaissance techniques the practical way—over familiar terrain with known objects. At the same time you learn the principles of camera construction and operation.

With a ready-to-fly weight of under one ounce the Camroc can be carried to high altitudes by lightweight model rockets. When mounted on a suitable launch vehicle such as the Astron Delta and propelled by the correct engines, camera and rocket will follow the flight path illustrated at right, taking a picture when the lens is pointed toward the ground.

A single exposure film disc is mounted in a detachable, light-tight film holder for quick and easy replacement in the field. The camera comes complete with one film holder loaded with an unexposed film disc and one empty film holder for practising and experimenting.

The kit includes complete instructions for camera assembly and operation as well as materials for practising and checking the camera's operation. NOTE: While the camera system is quite simple in its operation, we recommend that you first learn to build and fly model rockets correctly and only then advance to camera work if good results are to be obtained.

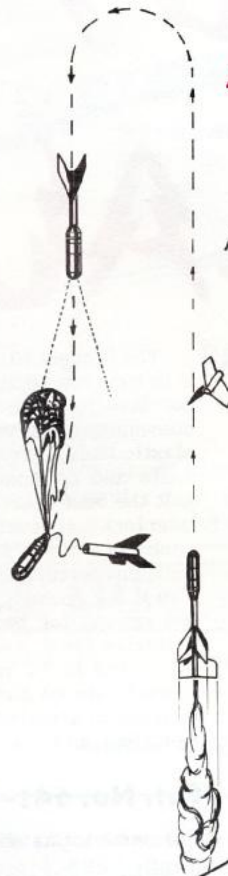

ADVANCE TO ROCKET
AERIAL PHOTOGRAPHY

ADD A NEW DIMENSION TO
YOUR MODEL ROCKET
ACTIVITIES

Specifications:
Diameter 1.6"
Length 5.3"
Fits: BT-50

**SPECIAL
COMBINATION
OFFER**

Complete Camroc kit plus Astron Delta kit. You save \$.50.

CAT. NO. 641-RC-1

\$4.00

CAT. NO. 641-C-1 \$3.00

(AVAILABLE DEC. 10)

(All items shipped postpaid.)

TYPES OF PICTURES

Some of the types of pictures which can be obtained with the Camroc are shown on this page and the next. The picture on the left shows farm land east of Estes Industries. This type of aerial photo, known as an oblique, is especially useful for mapping large areas.

The right hand photo, a low oblique, shows the engine manufacturing area at Estes Industries. The building in the center houses Mable, the engine-making machine. At the left of the picture is the end of the machine shop and part of one of the warehouses can be seen at the upper left. The two structures at the right in the picture are for propellant processing. Shown on the next page is a vertical photo of the Estes Industries main office.

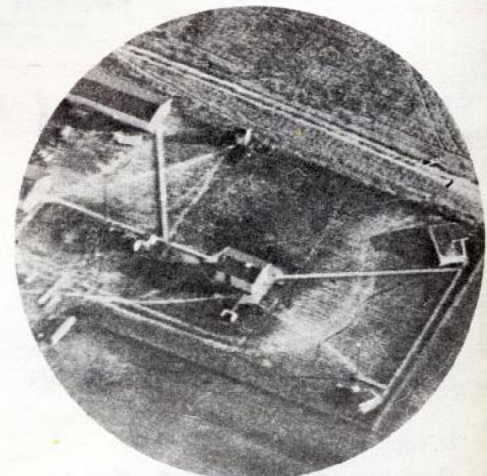
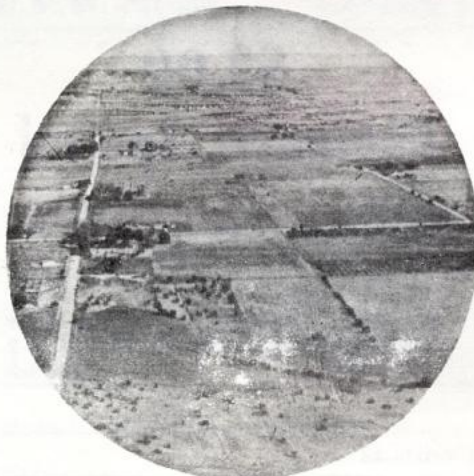

PROCESSING AND SUPPLIES

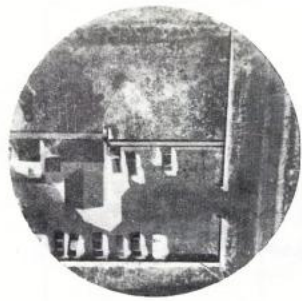

ACTUAL - SIZE
NEGATIVE 1-1/2"

PRINT SIZE 3"

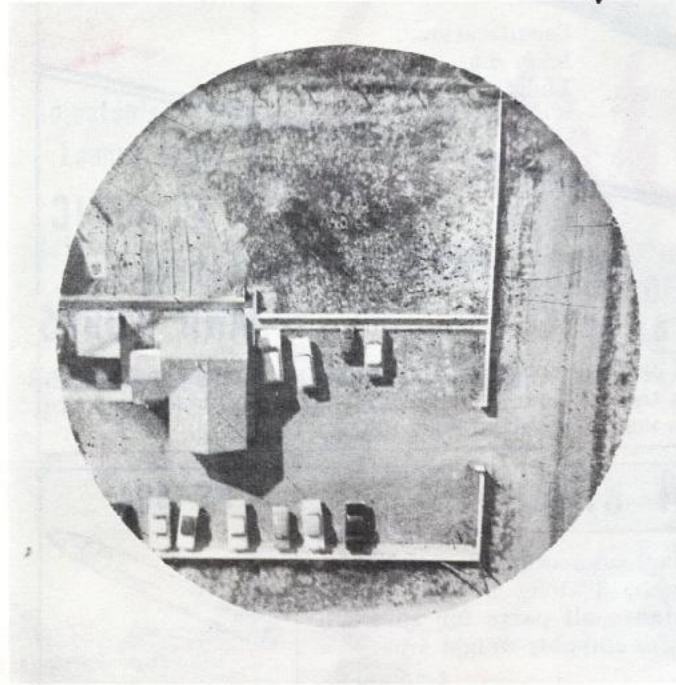

Rocketeers who have access to a photographic darkroom can develop and print negatives from the Camroc with no difficulty. For those who would rather not do their own processing, Estes Industries offers developing and printing services. All prints produced in the E.I. photo lab are enlarged 2 times from the negative size as shown.

FILM HOLDERS AND FILM:

Four sealed film holder sections for the Camroc, each pre-loaded with a fresh Astroman 400 film disc. A discount of \$.25 on the price of the loaded film holders is allowed for each used film holder returned at the time the order is placed. (Film holders containing exposed film returned for processing at the same time may be counted towards this discount. However, a discount will be allowed only on orders for loaded film holders.)

Cat. No. 641-FFH-4

4 for \$2.00

DEVELOPING AND PRINTING:

Film returned in film holders is developed under controlled conditions and one glossy print of each negative made at 2 times enlargement (3 inch diameter image). A refund of \$.20 will be made on any negative which does not meet the requirements for making a satisfactory print due to incorrect exposure, and the negative will be returned unprinted.

Cat. No. 641-FDP-1

\$.75 each,

4 for \$2.00

EXTRA PRINTS:

Additional prints at 2x enlargement of negatives which have been previously developed. The negative(s) must be enclosed in a suitable protective package with the order. (Please do not order additional prints until you have checked the negative and the first print to determine whether it is good enough to justify making additional prints.)

Cat. No. 641-NP-1

\$.40 each,

4 for \$1.10

FILM ONLY:

Six precut Astroman 400 film discs to fit the Camroc film holder. Packaged in light-proof double envelope. The envelope should be opened only in total darkness to prevent fogging of the film. (Loading instructions included in camera instructions.)

Cat. No. 641-NF-6

6 for \$.75

Specifications:
Length 13.6"
Body Dia. 1"
Weight 1.45 oz.

ASTRON DELTA

Specially designed as a booster vehicle for the Camroc, the Astron Delta features positive upper stage ignition, parachute recovery and high stability for the best camera operation in flight after flight. May be flown either as a single or multi-stage rocket, accepts a standard nose cone or payload section as well as a camera. Complete with all parts and instructions (nose section and engines not included). Shipping weight 8 oz.

CATALOG NO. 641-K-16

\$1.50

ENGINES FOR CAMERA ROCKETS

Cat. No. and Engine type	Total Impulse	Thrust Duration	Maximum Thrust	Time Delay	Engine Length	Initial Weight	Maximum Rocket Weight	Primary Use In Camera Rockets	PRICES		
									Each	3 for	12 or more
B5-0	1.15 lb.sec.	0.35 sec.	9.0 lb.	none	2.75 in.	0.61 oz.	6.0 oz.	Booster Only	\$.50	\$ 1.00	\$.53 each
B5-5	1.15 lb.sec.	0.35 sec.	9.0 lb.	5-5½ sec.	2.75 in.	0.69 oz.	5.0 oz.	Single Stage High Obliques	\$.50	\$ 1.00	\$.53 each
B5-6	1.15 lb.sec.	0.35 sec.	9.0 lb.	6-6½ sec.	2.75 in.	0.71 oz.	4.0 oz.	Single Stage Verticals	\$.50	\$ 1.00	\$.53 each
B5-7	1.15 lb.sec.	0.35 sec.	9.0 lb.	7-7½ sec.	2.75 in.	0.73 oz.	3.0 oz.	Upper Stage Verticals	\$.50	\$ 1.00	\$.53 each

(Production vehicle design subject to change)

THE PERFECT
VEHICLE
FOR CAMERA
LAUNCHING

NOTE: Catalog #651 will be published at the end of February and will be mailed out immediately thereafter to all rocketeers who are on our mailing list at that time.

AEROBEE 300

High-flying scale model of a great sounding rocket. Easily built, gives top performance flight after flight. Features parachute recovery for gentle landings, payload space for small specimens. Complete kit with all parts and easy-to-follow instructions (engines not included).

Cat. No. 641-K-17

Shipping weight 14 oz.
\$2.00 each p.p.

Flying Scale Model!





Specifications:
Body dia. 1"
Length 20"
Weight 0.85 oz.

**CLEAR PLASTIC
PAYLOAD SECTIONS
AND TUBES**

For BT-50
and BT-60

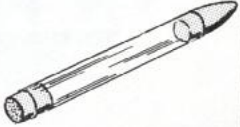
See-through plastic walls permit easy observation of payload condition, give models a unique appearance. Ideal for biological specimens or wherever a quick check on the payload is desirable. Smooth plastic surface gives an extra-slick finish with enamel paint. Specially designed to match standard body tubes.

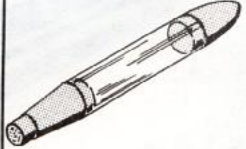
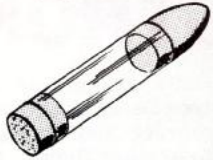
PAYLOAD TUBES	PAYLOAD SECTION KITS	
<p>PST-50S </p> <p>Four inch long clear plastic tube matches BT-50, measures 0.950" i.d. by 0.980" o.d. Requires self-adhesive paper (#PRM-1 or #TD-2) for gluing to balsa or other objects. Net weight only 0.11 oz., shipping weight 4 oz.</p> <p>Cat. No. 641-PST-50S \$.20 each</p>	<p>Complete clear plastic payload section kit, fits BT-50. Measures 0.950" diameter by 3" long inside, overall outside length 6.50". Includes all parts for easy assembly. Net weight 0.39 oz., shipping weight 4 oz.</p> <p>Cat. No. 641-PS-50A \$.90 each</p>	<p>PS-50A</p> 
<p>PST-60R </p> <p>Five inch long clear plastic tube to match BT-60, measures 1.595" i.d. by 1.637" o.d. Self-adhesive paper (#PRM-1 or #TD-2) is required for gluing to balsa, etc. Net weight 0.35 oz., shipping weight 6 oz.</p> <p>Cat. No. 641-PST-60R \$.35 each</p>	<p>Extra large clear plastic payload compartment kit for BT-50 rockets. Measures 1.595" diameter by 4" long inside and 10.5" long outside. Includes all parts plus extra launching lug and balsa standoff for rocket body. Net weight 1.04 oz. (may be reduced by hollowing nose cone and adapter), shipping weight 11 oz.</p> <p>Cat. No. 641-PS-50C \$1.30 each</p>	<p>PS-50C</p> 
	<p>High capacity clear plastic payload section for rockets using BT-60. Measures 1.595" diameter by 4" long inside and 9.5" long outside. Includes all parts and complete instructions, easy to assemble. Net weight 0.98 oz. (may be lightened by hollowing blasa nose cone and nose block), shipping weight 11 oz.</p> <p>Cat. No. 641-PS-60A \$1.30 each</p>	<p>PS-60A</p> 

Gift Certificate

Order Form

Amount: \$ _____

From: _____

To: _____

MAIL CERTIFICATE TO:

Name: _____

Address: _____

City: _____ State: _____ Zip: _____

A Gift Certificate is the convenient way of giving. It can be used in place of other gifts when you're not sure what the receiver would like. Fill out and mail this form or a reasonable facsimile to Estes Industries with your remittance in the amount desired for the gift. Your completed gift certificate will be returned via Air Mail. (Gift certificates make good gifts for birthdays and other occasions around the year as well as Christmas presents.)

DATE	CERT. NO.	ISSUED BY
------	-----------	-----------