

# MODEL ROCKET NEWS

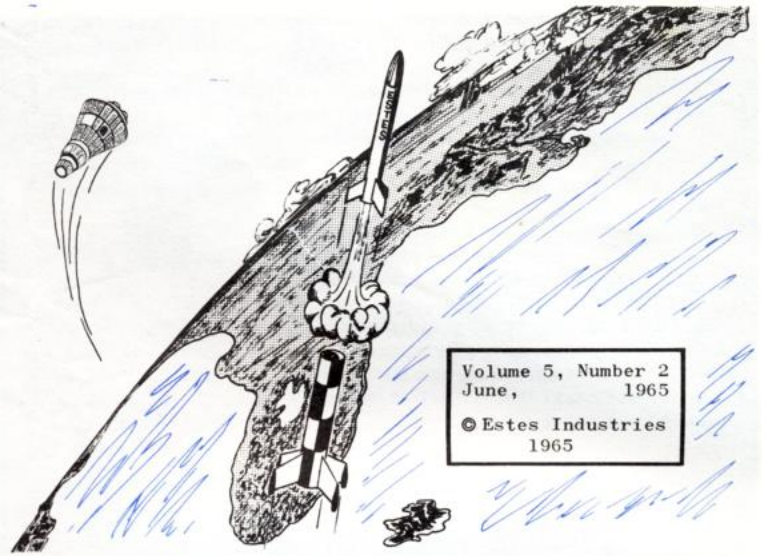

Volume 5, Number 2  
June, 1965  
© Estes Industries  
1965

## Photo Contest Winners!



Shown on this page and the next are some of the winning pictures from the photo contest which closed January 31. The entries included many excellent pictures and the rocketeers who sent them in deserve special congratulations. The ones presented here were awarded their places on a basis of composition, picture quality and subject interest.

Ed.

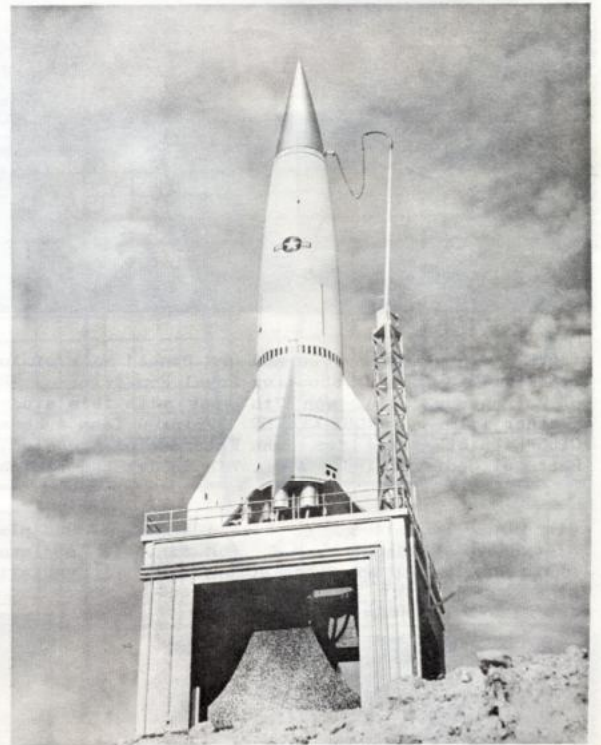

ABOVE: 1st place goes to Don Sahlin of New York, N.Y., for this group taken on Plus-X film. The close-up was taken by Rollicord Camera while the lift-off sequence was lifted from a 16 mm. movie strip shot with a Bolex.

ABOVE LEFT: 2nd place went to Rick Irvine and Gary Grimes both of Greeley, Colo., for their 9-photo series shot with a Pentax H3 using Tri-X Pan film. Exposure was f/16 at 1/1000<sup>th</sup> of a second.



LOWER LEFT: 3rd place was awarded to Fred Coy and Jeff Conner of Louisville, Ky., for this study in concentration. Camera was a Minolta SR-7 exposing Ektachrome-X film.

Blank Page Placeholder

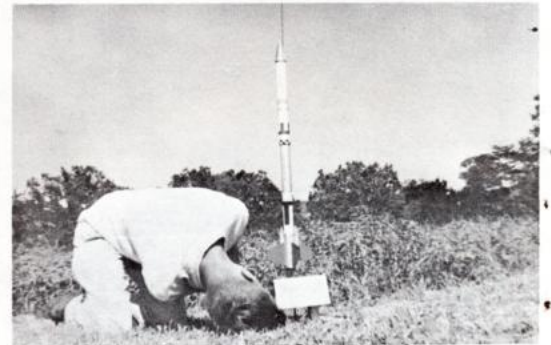
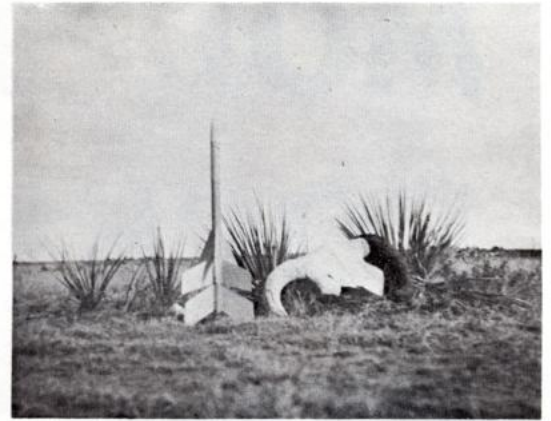

ABOVE: 4th place was earned by Donald Mack of Audubon Park, N. J., using a Graflex 3 1/4 X 3 1/4 camera shooting Royal Pan film. RIGHT TOP: Thomas Gerardy of Walsenburg, Colo. won 7th spot with this study of time and space. Camera? An Agfa Shur-Shot Special and Ansco 120 All-Weather film. RIGHT CENTER: Printed from a Kodachrome II slide taken by a Kodak Retinette IA, this photo entitled "Rocket Club" won 6th place for John Waterman of Evenston, Ill. RIGHT BOTTOM: A "hold" in the countdown took 8th place for Gary Potts of Bedford, Ind. A Brownie Bullet and Verichrome Pan film recorded this shot.

5th place laurels go to Edward Van Alstyne of Kinderhook, N.Y. for his photo of two future space scientists at work. A Petri 2.8 camera exposed the Plus-X 135 film.



9th place honors went to Jon Winborn of Iowa City, Iowa for his space age variation on a classical theme.



"Neither rain nor snow..." and Sam Vecchione of Uxbridge, Mass., as well doesn't allow weather to impede his rocketry progress... as seen in his 10th place Poloroid 110B shot on Type 42 film.



# New Products

## GRAPH PAPER

For rocket performance charts, stability graphs and countless other uses. In 8-1/2" x 11" sheets with a 7-1/2" x 10" grid area divided into 1/10" squares. Shipping wt. 4 oz.

Cat. No. 641-GP-1 20 Sheets for \$4.00



## CLEAR SPRAY

Crystal clear spray coating goes on clear--stays clear. Gives extra gloss to enamel finishes, protects decals and decorations, makes fluorescent finish smooth, durable and glossy. For best results, let paint dry thoroughly before applying clear spray, use several light coats for maximum gloss. In handy 5 oz. spray can. Shipping weight 16 oz.

Cat. No. 641-EP-2

\$1.20 each



## 2050 RINGS

Precision die cut card stock rings for centering and mounting BT-20 in BT-50. In sets of 20 rings, net weight 0.004 oz. per ring. Shipping weight 2 oz. per set.

Cat. No. 641-RA-2050 \$.30 per Set



## 2060 RINGS

Die cut rings for centering and mounting BT-20 in BT-60. In sets of 10 rings. Net weight 0.0165 oz. per ring, shipping weight 2 oz. per set.

Cat. No. 641-RA-2060 \$.30 per Set

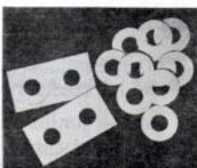

## IGNITER (Patent Pending)

Easy-to-use, extra reliable igniters--the same as are now supplied with all Estes engines. Suitable for ignition systems of 6 volts or more. Shipping weight 1 oz.

Cat. No. 641-NWI-1

6 for \$1.15

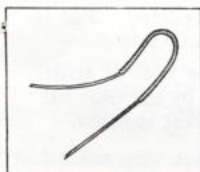

## MODEL ROCKET NEWS

The Model Rocket News is published four times annually by Estes Industries, Inc., Penrose, Colorado. It is distributed free of charge to all the company's mail order customers from whom a substantial order has been received within a period of one year. The Model Rocket News is distributed for the purpose of advertising and promoting a safe form of youth rocketry and for informing customers of new products and services available from Estes Industries. Rocketeers can contribute in several ways towards the publication of the Model Rocket News:

- (1) Write to Estes Industries concerning things you and your club are doing in this field which might be of interest to others.
- (2) Continue to support the company's development program by purchasing rocket supplies from Estes Industries, as it is only through this support that free services such as the Model Rocket News, rocket plans, etc., can be made available. This support also enables the company to develop new rocket kits, engines, etc.
- (3) Write to the company about their products and tell what you like, what you don't like, new ideas, suggestions, etc. Every letter will be read carefully, and every effort will be made to give a prompt, personal reply.

Vernon Estes  
Publisher

William Simon  
Editor

## STREAMER RECOVERY

by Gary Adams

For smaller model rockets streamer recovery is often the best system to use. It is lightweight and easy to use, cuts down on drifting in a breeze and is inexpensive while providing safe recovery for the model. Streamer recovery has been used with great success in many different applications. In addition to the recovery of small sport and competition models, it can be used for the recovery of payload sections, spent engine casings and booster stages.

Since it works by deploying a drag member, the streamer can be considered an interim step between the featherweight system and parachute recovery. A general layout is shown in figure 1. Streamer placement and ejection work in the same manner as the parachute. While the method of deployment is the same, the streamer recovers the model in a somewhat dif-

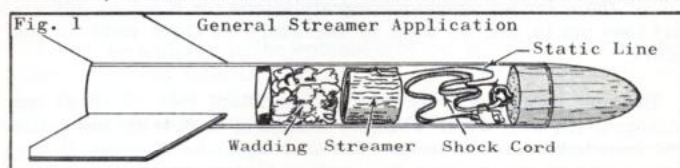

ferent way. The parachute traps air to create a large frontal area while a streamer breaks up the stability of the model and creates high surface drag.

Streamers can be made of crepe paper or plastic film. The plastic is least used since its surface is smooth and will not create the same amount of drag as crepe paper. The rough surface of crepe paper disturbs the air flowing around it, helping to make it flutter as it descends.

When the nose cone and streamer are ejected the streamer will make the rocket unstable if it is large enough. Generally a one inch wide streamer should be 10 inches long for each 3/4 ounce of rocket weight. A two inch wide streamer requires about 3/4 the length of a one inch wide one.

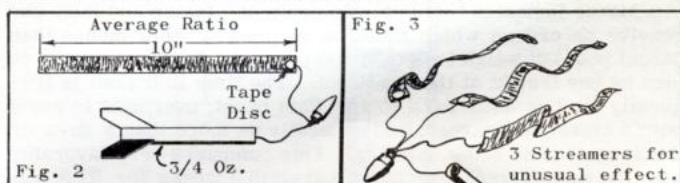

When using paper streamers select a material which has been treated to make it flame resistant. A nylon cord or shroud line should be used to connect the streamer to the screw eye of the nose cone. A length of shock cord is used to attach the nose cone to the rocket body.

Multiple streamers are an unusual variation in recovery methods. Several streamers are attached to a common line as shown in figure 3. By using three or four small streamers joined together a lower sink rate than that of a single streamer with equivalent length can be obtained.

A method that has been used successfully on single streamer models to obtain a lower sink rate is an off-center, twisted streamer. To construct one take a piece of material about three feet long and push the point of a snap swivel through the corner of a folded over end of the material. Twist the paper one complete turn, attach the other end (do not double) to the swivel and snap it together. This system is best for larger models since it is harder to pack into the body and its high resistance is not needed in small models.

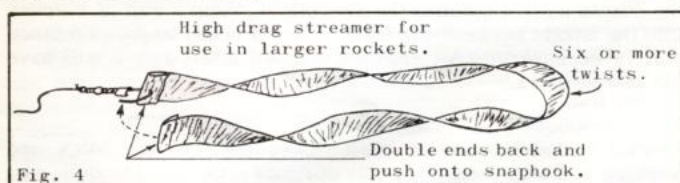

When preparing the model for flight the streamer should be rolled tightly with no overlapping edges. When it is inserted into the rocket body it should not be a tight fit. The same amount of wadding as would be used with a parachute should be packed into the body between the streamer and the engine.

# NOTES FROM THE BOSS



We were very pleased with the many entries received in the Photo Contest. There were many very good pictures, and the range of subjects and methods of treatment was truly fantastic. All of the entrants deserve congratulations for the time and effort they put in, and we hope to see more of their work in the future.

Because photography is such an important tool of all of the sciences, it's well worth while for a student to develop his skills and knowledge in this field. The techniques he develops in applying photography to model rocketry can very easily carry over into his future profession with the result that he is able to do more work of real value. Even in his science projects today photographic records of experiments add greatly to the effectiveness of the project. This is one of the reasons why we run contests of this sort--to encourage the development of useful skills and to recognize those who do outstanding work. If you didn't enter this contest, we hope you'll enter the next one. Even if you don't win, the work you'll have done will help you--and if you keep trying there's a very good chance that you'll win eventually.

Discount orders, especially those including more than 50 engines, often cannot be shipped by parcel post. Normally, this means that shipment is made via REA express. However, our experience indicates that bus shipments are faster and less expensive on orders which must be shipped by other means than parcel post but weigh less than 100 pounds. It is necessary to pick up bus freight at the bus depot. The time in transit is frequently as low as 3 days to the East coast, overnight to some points closer to Penrose, and generally no more than 5 days on the longest time cross-country. This compares very favorably with the up to 2 weeks for truck and up to 3 weeks for REA express. If you're a dealer, or will be sending in a quantity discount order and would like to try this, please specify on your order form.

The new igniter (see page 12) is, in our opinion, a considerable improvement over the old materials and methods. We've been working on the problem off and on (mostly off) since 1960, and it looks like we've finally reached a solution.

First of all, the portion of the igniter that fits into the nozzle is electrically insulated, so there's little chance of a short circuit causing a misfire. The igniter is designed so it heats most in the portion that is inside the nozzle, concentrating the heat where it is needed. Then, the composition is in intimate contact with the heating portion of the wire, so no heat is lost, and when the composition ignites, it in turn ignites the engine immediately. This combination results in a faster, more positive igniter that requires less power. Finally, the new igniter is easier to install. You simply bend it in the middle, insert it into the nozzle until it touches the propellant, tamp a wad of kleenex into the nozzle between the leads and it's ready to go. No fancy coil is necessary. All engines shipped after July 1 will have the new igniters.

Two rocketeers whose work you've seen in the MRN are working at Estes Industries this summer. Gordon Mandell, who wrote the technical reports on boost-giders, is designing and building a new wind tunnel for our research dept. Dean Black, who wrote the article on fins in Volume 3, Number 3, is working on kit design and development. Both are headed for college this fall. Gordon will be starting at MIT; Dean at the University of Utah.

# LETTER SECTION



We have received our order and would like to thank you for the quick service.

At Red Creek Central School the students are introduced to model rocketry in three ways. They receive information about it through their seventh and eighth grade science classes; through a unit on model rocketry in General Industrial Arts I under the area of Power Mechanics and Transportation; and through the model rocket club on the junior high school level.

The model rocket club is in its second year of existence and is under the joint advisorship of Mr. Matthew Osterhault, junior high science teacher and myself.

In all three instances our objectives are basically the same:

1. To orient and acquaint the students with the different types of space vehicles and their theory of operation
2. To provide an opportunity for creative expression and problem solving through research and experimentation.
3. To help the student acquire a basic understanding of the tools, materials, processes and occupations related to the rocket industry.
4. To help the student develop safe practices and learn to abide by the rules of the National Rocketry Association.

Both Mr. Osterhault and myself feel that the students interested in model rocketry must have some guidance. In the case of our school district and the fact that this is a rural community the guidance must come from the school.

At the Industrial Arts level I have managed to put the interest of model rocketry to work in several of my courses.

At the junior high level in General Industrial Arts I the students build the rockets as part of the course. This is the only course where work in this area is really required. However, at the senior high level the knowledge that the boys have about model rocketry helps our program in model rocketry. For instance:

- A. The Mechanical Drawing students in one unit of their work design a rocket to be constructed by the General Industrial Arts I students using your rocket engines.
- B. A switchboard for use in firing the rocket was needed by the General Industrial Arts I students and the model rocket club. The case and circuit were designed by an elec-electronics student who had a background in mechanical drawing and metalworking. The case is to be built in the metalworking course and wired in the elec-electronics course.

These are the ways that I have used model rocketry in my program.

We hope to have a safe and fruitful future in model rocketry.

Vincent C. D'Ambrosio  
Chairman Voc-Industrial Arts  
Department  
Red Creek, N. Y.

(Those who've been wondering how to fit model rocketry into the school curriculum should get some good ideas from Mr. D'Ambrosio. Ed.)

My girlfriend and I found a yellow and red plastic parachute with a red-type rocket or bullet attached. If you are interested, it came down some time today June 22, 1965, in our garden.

Kathy Janson  
Baldwin, L. I., N. Y.

(That's what you Wisconsin boys get for launching your birds in high winds. Ed.)

# The Idea Box

## DOUBLE DUTY DOWELING

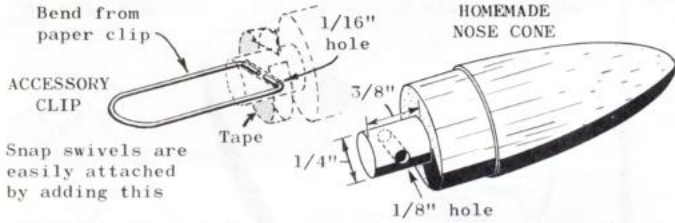

Snap swivels are easily attached by adding this

PHILIP BILLINGS of Monroeville, Penna., suggests letting the dowel substitute for a screw eye on homemade nose cones--just cut off and drill as shown.

## LOOK!... NO CUTTING!

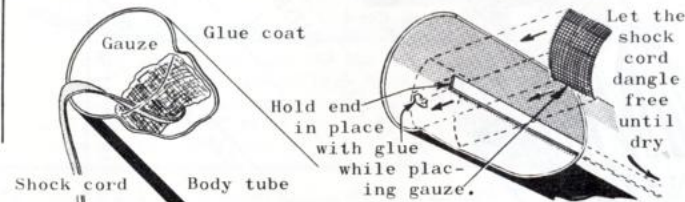

For an invisible shock cord attachment try this idea from EDWARD LIPMAN of Hamden, Conn. Let the glue dry until it is clear before stretching the cord. (A "natural" for scale models.)

## MAILING TUBE PARTS BIN

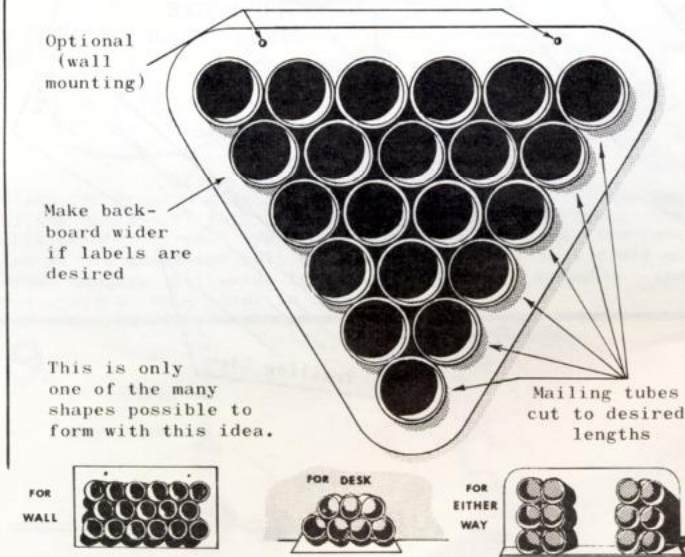

DOUGLAS CURTIS of Pittsfield, Mass., suggests using mailing tubes for storage bins. For most small parts cut the tubes into 5 equal lengths--or 4 lengths for engine storage. Form the honeycomb to the desired shape and glue to a backboard.

## REMEMBER

\$5.00 Gift Certificates are awarded for each idea used in this column. In event of idea duplication, the best presentation gets the award.

## STRAIGHT & SHARP

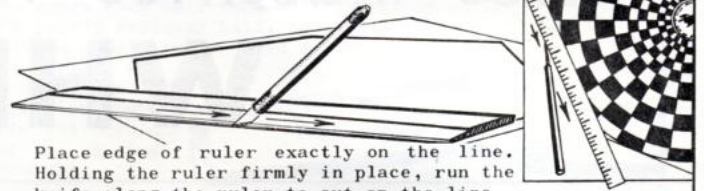

Place edge of ruler exactly on the line. Holding the ruler firmly in place, run the knife along the ruler to cut on the line.

Trim parachutes neatly with a metal straightedge and knife as in this idea by TIM and TOM HUFF of Wickenburg, Arizona. Protect your working surface with a thick mat of newspaper.

## MEET A 'CHUTE HANGER...

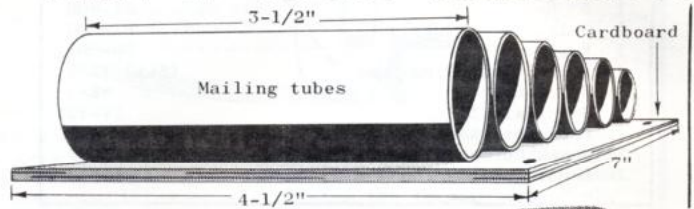

Hang the unit on wall with picture hooks or cup hooks as shown.

Write 'chute size on a bit of masking tape and apply to tube near the top.

DAVID BARNES of Corinth, Ky. uses mailing tubes to keep spare 'chutes ready for action in this handy storage rack.

## A GOOD PRIMER COAT...

Resists wear and damage to front of body tubes

Gives good seal with one light coat..

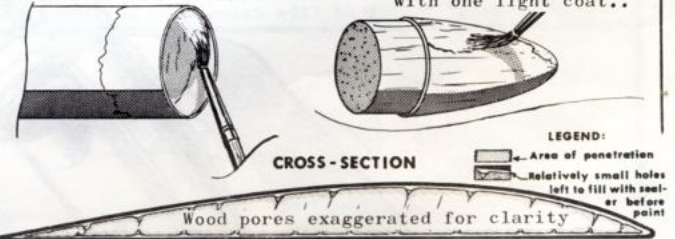

Mix equal parts of white glue and water to seal the pores in balsa parts or protect body tubes at points of wear, recommends PAUL C. CONNER of Riverdale, Md. Apply in thin coats to prevent running if brushed on. Dry until clear before proceeding with filler and final paintwork.

## KNIFE AND METAL RULER MAKE HANDY SHAPER

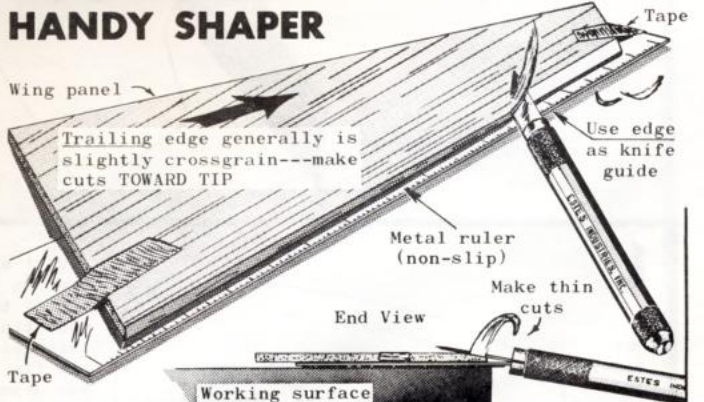

Airfoils may be quickly shaped using a flat blade to carve away the excess balsa as shown. Practice with scrap until you can maintain good control of cutting depth and angle.

# Estes Industries Rocket Plan No. 34

## WHEE II

Published as a service to its customers by Estes Industries, Inc., Box 227, Penrose, Colorado © Estes Industries, Inc. 1965

### Parts List

2 Balsa Nose Cone	Part No. BNC-60L
2 Balsa Fin Stock	BFS-20
1 5" Body Tube	BT-60R
1 3-1/2" Body Tube	BT-20G
1 Engine Block	EB-20A
1 2060 Spacer Ring	(Set) TA-1
1 Screw Eye	SE-1
1 Snap Swivel	SV-12
1 Parachute Kit	PK-12
1 Shock Cord	SC-1
1 Launching Lug	LL-1B

In addition to the parts listed above, you will need a model knife with gouge blade, scissors, white glue, ball point pen, 1 sheet each of fine and extra fine sandpaper and a piece of reinforcing gauze 1/2" by 1" in size.

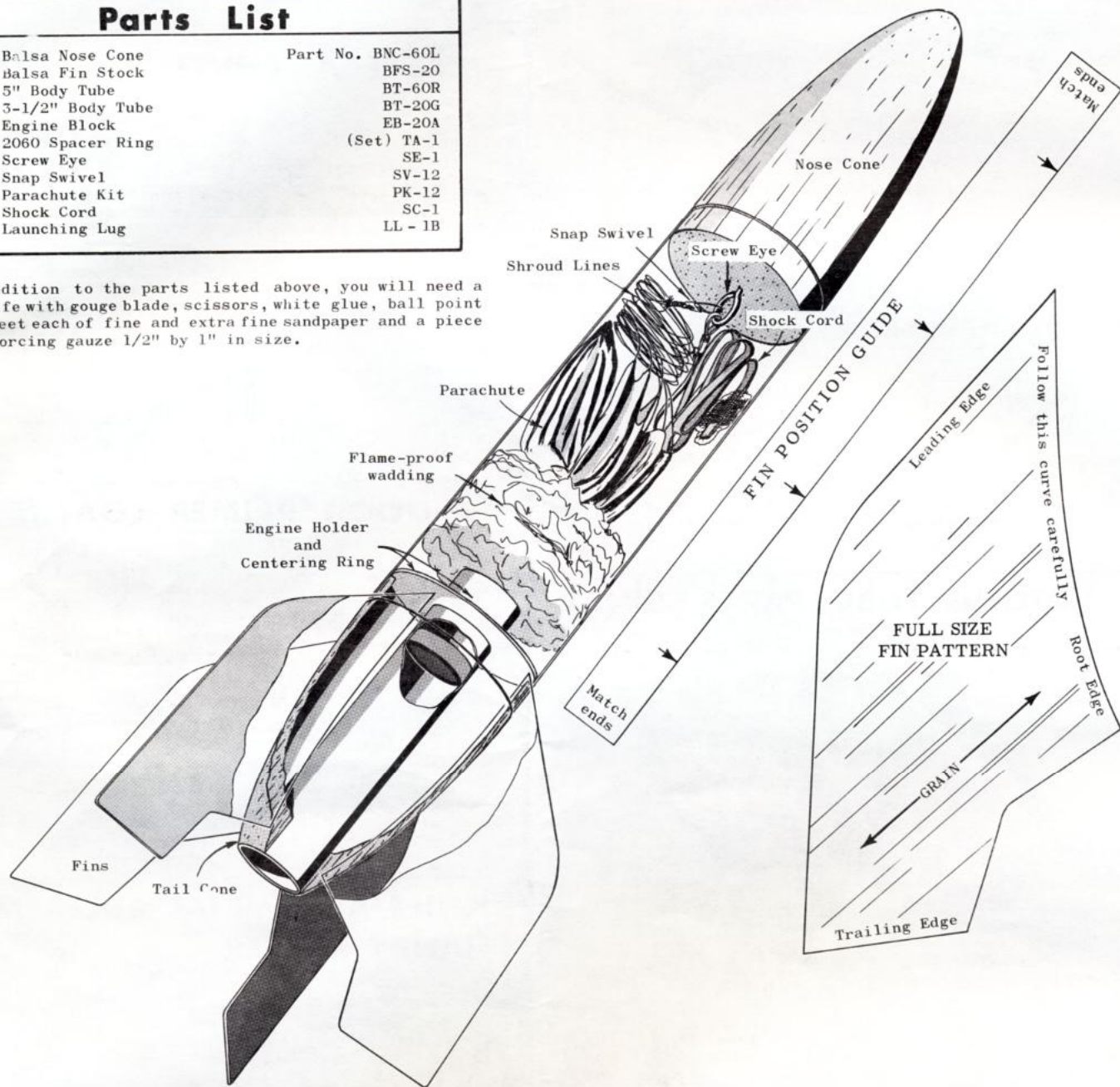

**1.**

Locate Tip Center

Tail Cone

5" Body Tube

Insert one nose cone in the 5" body tube and wrap the fin position guide with arrows pointing to the tip of the cone as shown. Locate the center of the cone tip and draw a line from each arrow through this point as shown. Center the engine tube over the tip of the cone and mark all the way around as shown on the right.

3-1/2" Engine Tube

Mark all the way around

2.

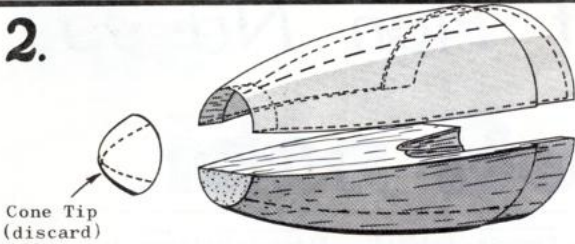

Cut away the tip of the cone and discard. Split the cone for hollowing and carefully gouge each half to a wall thickness of 1/8". At left is seen a partly hollowed half, and above it is shown how both pieces should appear when finished. Glue the pieces together. Use the small tube as a size gauge and finish the engine tube outlet to be a slide fit. Tape the tube or sand the opening to accomplish this fit.

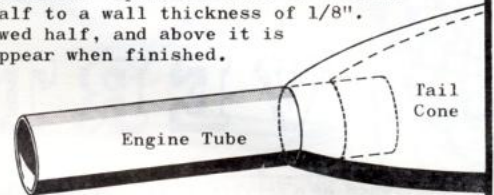

3.

Spread glue 1-1/4" down one end of the 3-1/2" body tube and insert the engine block into the other end. Press the block into the tube 2-1/4" with an empty engine casing. Slide on (do not glue) the 2060 spacer ring onto the front of the tube

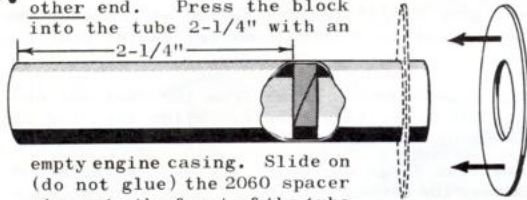

4.

Slide ring into firm contact with cone. Apply glue to this edge all around. Run fillet around this joint when ring is in place. Tube flush with cone.

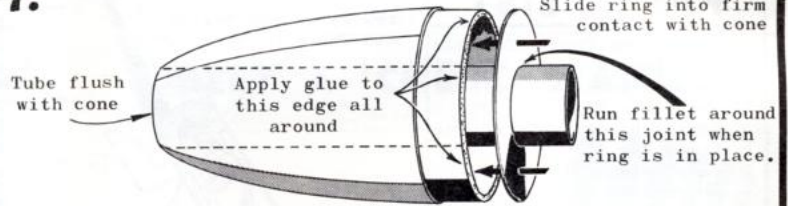

Spread glue inside the tail cone at the engine tube outlet. Slide the tube into place fitting the end flush with the end of the cone. Spread a line of glue around the front of the cone and slide the 2060 ring into contact. Center the forward end of the engine tube in the tail cone with this ring.

5.

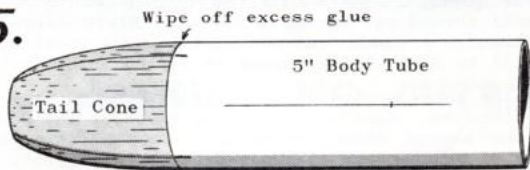

Apply glue inside one end of the 5" body tube and install the tail cone assembly. Draw a guide line midway between fin locations for the launching lug. Draw a small mark 1-3/4" from the forward end of the tube to show where the front of the lug will locate.

7. Shown are the launching lug and shock cord in their installed positions. Shock cord details are shown.

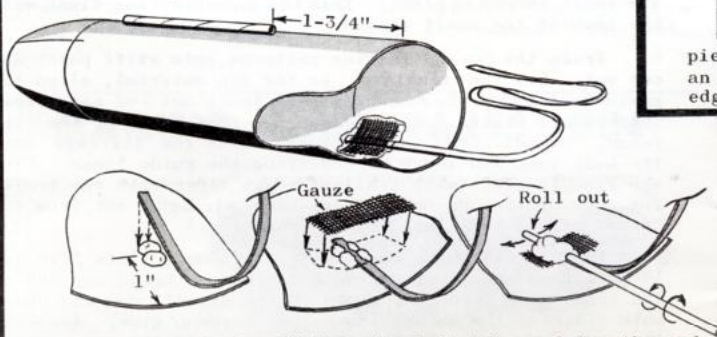

Place two drops of glue 1" into the body tube and lay the end of the shock cord into this. Lay the reinforcing gauze over this point as shown. Apply 5 or 6 drops of glue over the center of the gauze and roll out to either side with a dowel or brush handle. Set aside to dry completely. Assemble the parachute at this point in construction.

6.

Trace the fin pattern onto stiff paper. Lay the template on the finstock as shown and carefully trace two fins on each

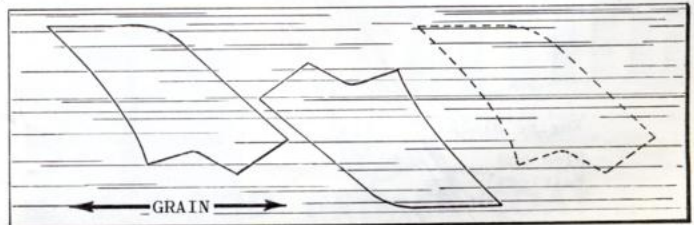

piece. You'll have spare wood for two more fins in case of an accident. Carefully cut out and sand the fins. Make all edges round except the root which will be fitted later.

8.

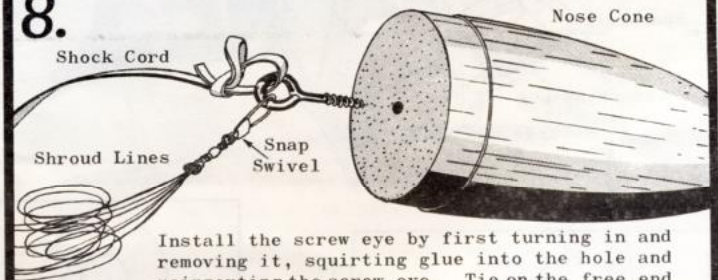

Install the screw eye by first turning it and removing it, squirting glue into the hole and reinserting the screw eye. Tie on the free end of the shock cord and clip on the snap swivel.

9.

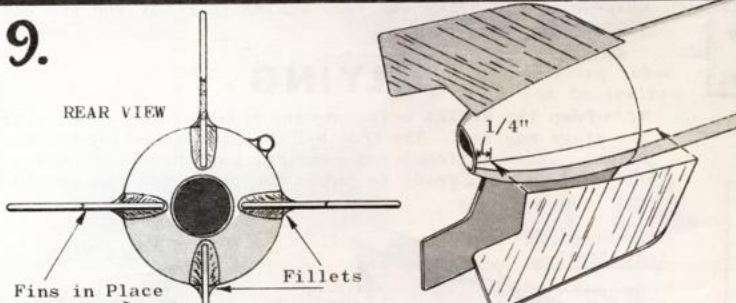

With parachute, nose cone and all other parts of the rocket in place, select one fin and one guide line to which the fin will be fitted, then glued. Carefully sand the root edge until contact is made along its entire length. Apply glue and align the fin to stick straight out from the tail cone and be in line with the centerline. Do the same with the other three fins and when dry, apply a generous fillet to each. Dry your WHEE II completely and paint to suit your taste. Prep your bird and start the countdown...5...4...3...2...1...LAUNCH!

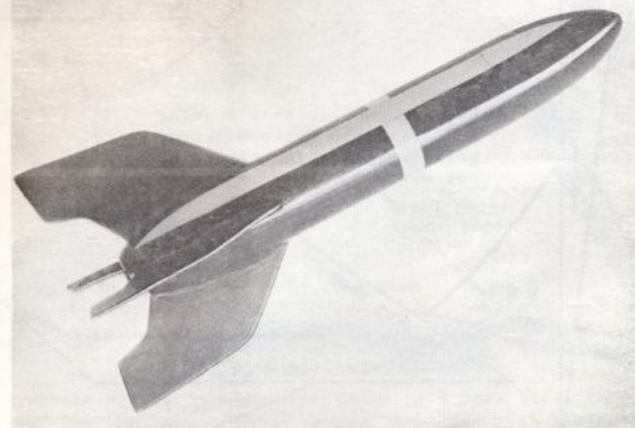



# Estes Industries Rocket Plan No. 35

## VERTEX

### SPORT ROCKET

Published as a service to its customers by Estes Industries, Inc., Box 227, Penrose, Colorado. Estes Industries, Inc. 1965

#### PARTS LIST

1	Balsa Nose Cone	#BNC-20R
1	Body Tube	BT-20B
1	Balsa Fin Stock	BFS-20
1	Parachute Kit	PK-12
1	Engine Block	EB-20A
1	Screw Eye	SE-2
1	Snap Swivel	SV-12
1	Shock Cord	SC-1
1	Launching Lug	LL-1B
1	Tube Adapter Set	TA-1

#### BUILDING...

1. Spread glue 2-1/4" inside one end of the body tube and install the engine block using a marked engine casing to push it forward.
2. Select a 2060 spacer ring from the TA-1 set and cut a 5/32" hole next to the center hole. Slide the ring onto the rear of the body tube 1/16" from the end and glue.
3. Cut out the large shroud on the BT-20 and BT-60 lines and lay it over the shroud drawing. Draw a line at each point shown. Draw the launching lug cut out. Form the shroud and cut away the portion needed to allow launching lug space. For the small shroud cut on the BT-20 and BT-50 lines and form the shroud. A small cut-out must be made in this one too, but will be done as the shroud is fitted into place.
4. Slide the large shroud onto the body tube and position it against the ring. Mark the tube at the front of the shroud and slide the shroud ahead far enough to expose this mark. Apply a line of glue around the body tube at this point. Align the launching lug cut out and the 5/32" hole and slide the shroud into place. Apply a line of glue around the joint between the ring and the shroud.
5. Push the launching lug through the 5/32" hole until the end just emerges from the shroud. Trim away the lug as shown and apply glue around the shroud-lug joint. Fit the small shroud and mark the area to cut away to admit the launching lug. Cut out that area and if the fit is satisfactory, glue the small shroud in place. Trim the launching lug flush with the rear of the small shroud.
6. Trace the fin and fairing patterns onto stiff paper and cut out. Lay the templates on the fin material, align the grain arrows with the wood grain and trace out 3 of each item. Cut out all pieces. Sand all but the root edges of the fins round. Do not round the fairings. Glue the fairings onto the body tube and large shroud along the guide lines. Glue the fins in place with trailing edges flush with the trailing edge of the shroud and sticking straight out from the center of the body tube. (See rear view.)
7. Install the shock cord by cutting small slots 3/4" and 1" back from the front of the body tube. Thread one end of the shock cord through as shown in the overall view and cover both sides of the connection with a layer of glue. Assemble the parachute and tie the shroud lines to the snap-swivel while the shock cord connection dries.
8. To secure the screw eye in the nose cone, turn the screw eye into place and remove. Squirt glue into the hole and reinsert the screw eye. Wipe away any excess glue from around the eye and tie on the free end of the shock cord. Clip the snap-swivel in place and your VERTEX is ready for the paint job of your choice.

#### FLYING...

9. Prep the VERTEX using any one of the Series I or II single stage engines. The 1/2A.8-2 is recommended for the first flight. Insert flameproof wadding, parachute and nose cone and your model is ready to put on the pad, connect, countdown and launch.

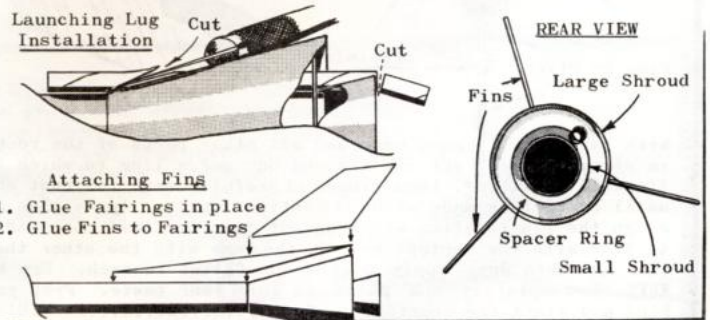
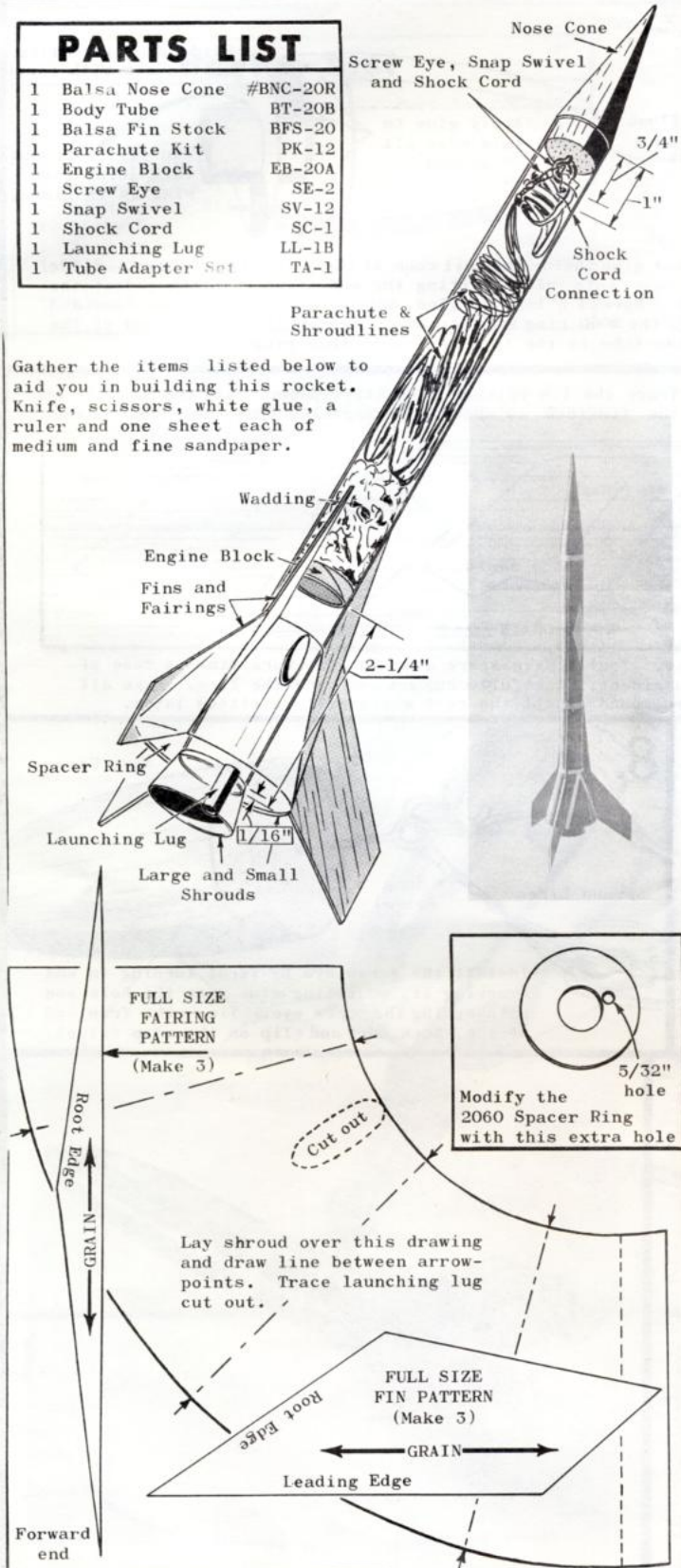

1. Glue Fairings in place
2. Glue Fins to Fairings

Gather the items listed below to aid you in building this rocket. Knife, scissors, white glue, a ruler and one sheet each of medium and fine sandpaper.

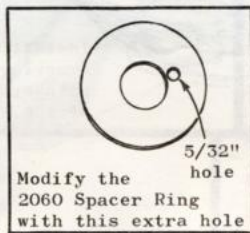
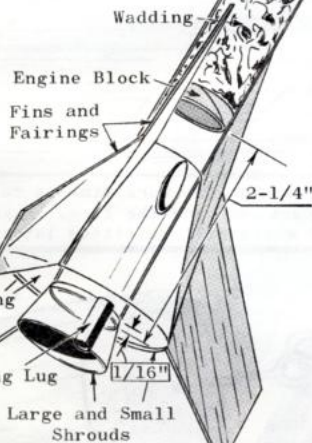

FULL SIZE FAIRING PATTERN (Make 3)

Lay shroud over this drawing and draw line between arrow-points. Trace launching lug cut out.

FULL SIZE FIN PATTERN (Make 3)

Forward end

# Estes Industries Technical Report No. TR-9

## DESIGNING STABLE ROCKETS

by William J. Taylor, III

These reports are published as a service to its customers by Estes Industries, Inc., Box 227, Penrose, Colorado  
Copyright 1965 by Estes Industries, Inc.

Model rockets can be designed to be stable by using the principle of moments and centroids. The advantage of this method to model rocket builders is that it is very accurate, yet doesn't

require a knowledge of higher mathematics. This accuracy has been proven in wind tunnel tests.

### METHOD OF DESIGN

The first step is to decide what kind of rocket you want to design and which component parts you want to use. After this decision has been made the design is started by weighing each item to be used. For the time being, the rocket's fins are completely ignored. Using the weight of each component part we find the center of gravity of the whole rocket neglecting the fins. The next step is to determine the cross-sectional area of the components that are exposed to the freestream (for our purposes this will be the portion of the nose cone that protrudes from the body tube, the body tube and any portion of the engine that extends out of the body). With these areas we can calculate the center of pressure.

These calculations will show that the center of pressure is significantly ahead of the center of gravity. With the center of pressure ahead of the center of gravity the rocket is likely to be highly unstable--with disastrous results. In order to move the CP behind the CG we add fins. The size of the fins determines where the final CP of the rocket will be. If we decide to locate the CP 1-1/2 diameters of the body tube behind the calculated CG we can determine the exact fin area needed.

### CENTER OF GRAVITY (CG)

The center of gravity of the complete rocket is found by accurately weighing each component of the rocket, determining the center of gravity of each part and then applying the principle of moments. A table (fig. 1) should be made with the various weights and the distances of the CG's from a reference line taken at the nose cone tip.

ITEMS	WEIGHT	DISTANCE OF CG FROM THE REF. LINE	WEIGHT TIMES DISTANCE
NOSE CONE	$W_1$	$D_1$	$W_1 D_1$
PARACHUTE	$W_2$	$D_2$	$W_2 D_2$
ENGINE BLOCK	$W_3$	$D_3$	$W_3 D_3$
BODY TUBE	$W_4$	$D_4$	$W_4 D_4$
LOADED ENGINE	$W_5$	$D_5$	$W_5 D_5$
TOTAL, ( $\Sigma$ )	$\Sigma W$		$\Sigma WD$

W - WEIGHT OF ITEM  
D - DISTANCE OF ITEM CG FROM REFERENCE LINE  
 $\Sigma$  - GREEK LETTER SIGMA, MEANING THE TOTAL

### CENTER OF GRAVITY : (CG)

$$CG = \frac{\Sigma WD}{\Sigma W}$$

Fig. 1

All of the weights in the column labeled WEIGHTS should be added up. This total is referred to as the "Weight Summation" or simply the total weight. The Greek letter Sigma ( $\Sigma$ ) is commonly used to indicate summation, or the total.

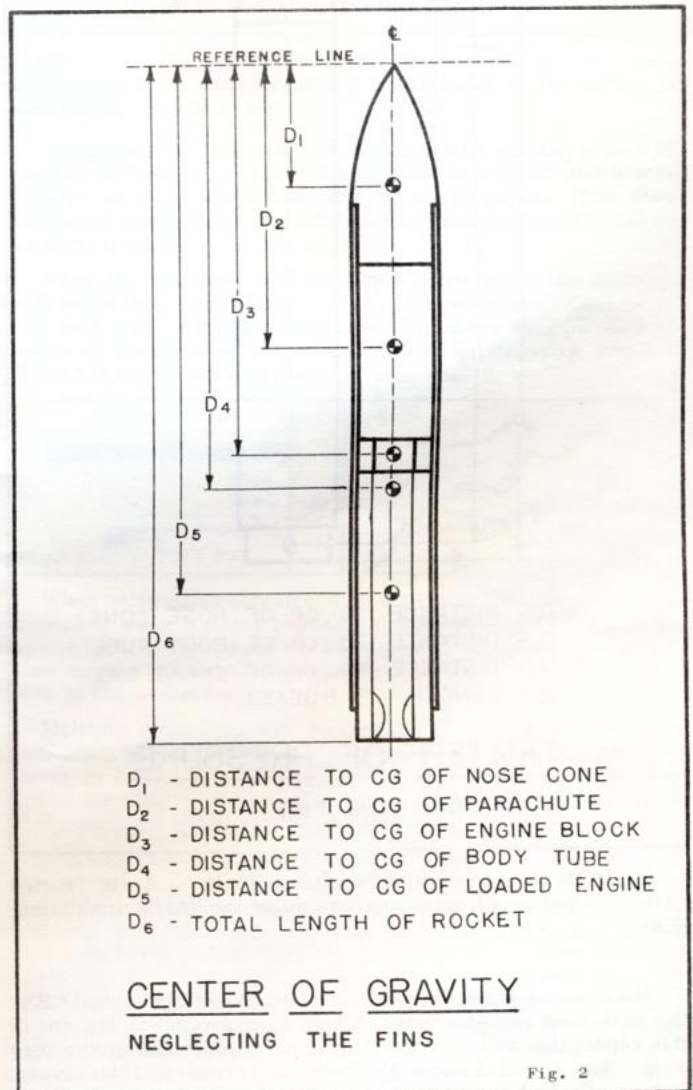

The distance from the reference line to each individual CG is the next item to determine. This can be found by balancing the item on a knife edge and then measuring this balance point's distance to the furthest forward point of the component. This distance is added to the distance between the reference line and the forward point on the part to find the item's CG distance from the reference line.

Next, multiply the weight by the distance and put the result in the column labeled "WEIGHT TIMES DISTANCE." This must be done for each item. All of the different products are then added up. This total is called the "Moment Summation, ( $\Sigma WD$ ).

Finally the values obtained from the table are substituted into the formula shown in fig. 1. Divide the WD summation by the W summation to find the CG distance from the reference line.

**CENTER OF PRESSURE (CP)**

The center of pressure is determined by accurately calculating the cross-sectional area of the components of the rocket which are exposed to the freestream in flight. Fig. 3 illustrates the portions of the rocket to be considered. Part of the nose cone is inserted into the body tube and is not used in this calculation. All of the body tube is exposed so we use all of it. The engine usually sticks out 1/4 to 1/2 inch and the part that sticks out must be included. You will notice that we are still not considering the fins.

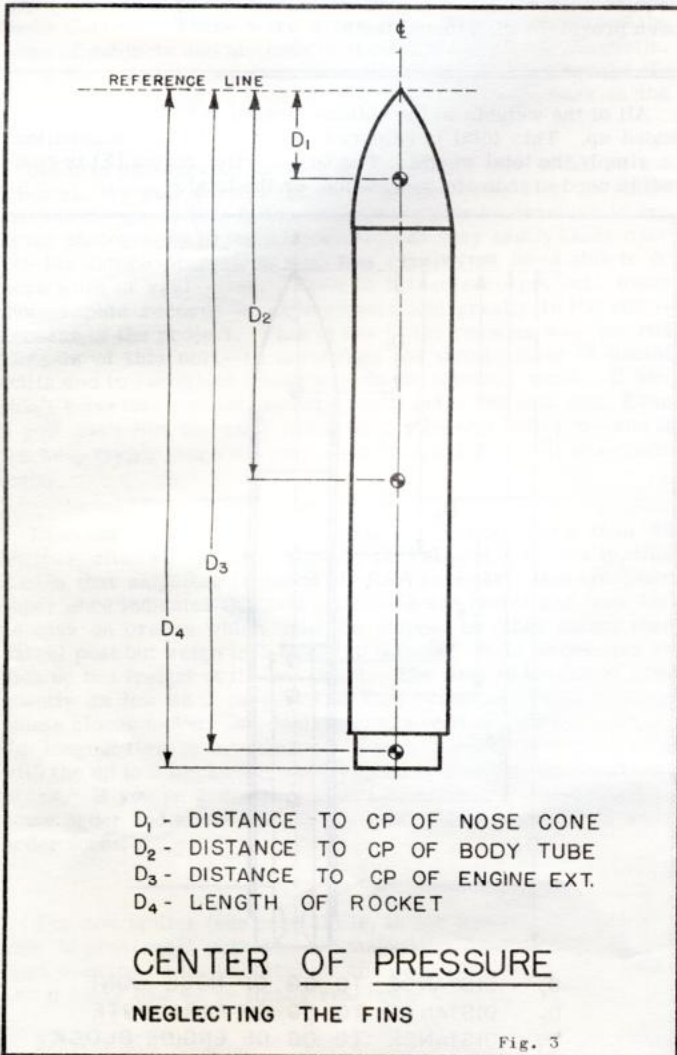

All of these areas should be listed in the column labeled "AREA." Add up all of these areas to get the "Area Summation, (ΣA)."

The distance from the reference line to each individual CP is the next item to determine. There is a section at the end of this report that will show you how to determine this for the nose cone. The CP of a rectangle (body tube cross-section) always lies exactly half way between its sides (1/2 of the length of the body tube). This distance is added to the exposed length of the nose cone to give you the distance from the reference line to the body CP. The exposed section of the engine is also a rectangle. Its CP is exactly 1/2 of the exposed length. The exposed engine CP is then added to the body tube length and the exposed nose cone length to give its CP distance from the reference line.

Finally the values obtained from the table are substituted into the formula shown in fig. 4. By dividing the AD summation by the A summation the CP distance from the reference line is calculated.

ITEMS	AREA	DISTANCE OF CP FROM THE REF. LINE	AREA TIMES DISTANCE
NOSE CONE	A <sub>1</sub>	D <sub>1</sub>	A <sub>1</sub> D <sub>1</sub>
BODY TUBE	A <sub>2</sub>	D <sub>2</sub>	A <sub>2</sub> D <sub>2</sub>
ENGINE EXTENSION	A <sub>3</sub>	D <sub>3</sub>	A <sub>3</sub> D <sub>3</sub>
TOTAL, (Σ)	Σ A		Σ AD

A - AREA OF ITEM  
 D - DISTANCE OF ITEM CP FROM REFERENCE LINE  
 Σ - GREEK LETTER SIGMA, MEANING THE TOTAL

**CENTER OF PRESSURE = (CP)**

$$CP = \frac{\sum AD}{\sum A}$$

Fig. 4

**FIN AREA DETERMINATION**

Figure 5 illustrates the points of the CP and CG that we calculated. Also shown is the position of the stable CP and the arbitrary point that we have chosen for the center of pressure of the fins. This arbitrary fin CP can be chosen at any point behind the stable CP. The illustration shows a symmetrical rectangular fin which is the easiest to use. Swept back fins will have their CP at a point farther behind the stable CP. When the fin CP is moved farther behind the stable CP the required

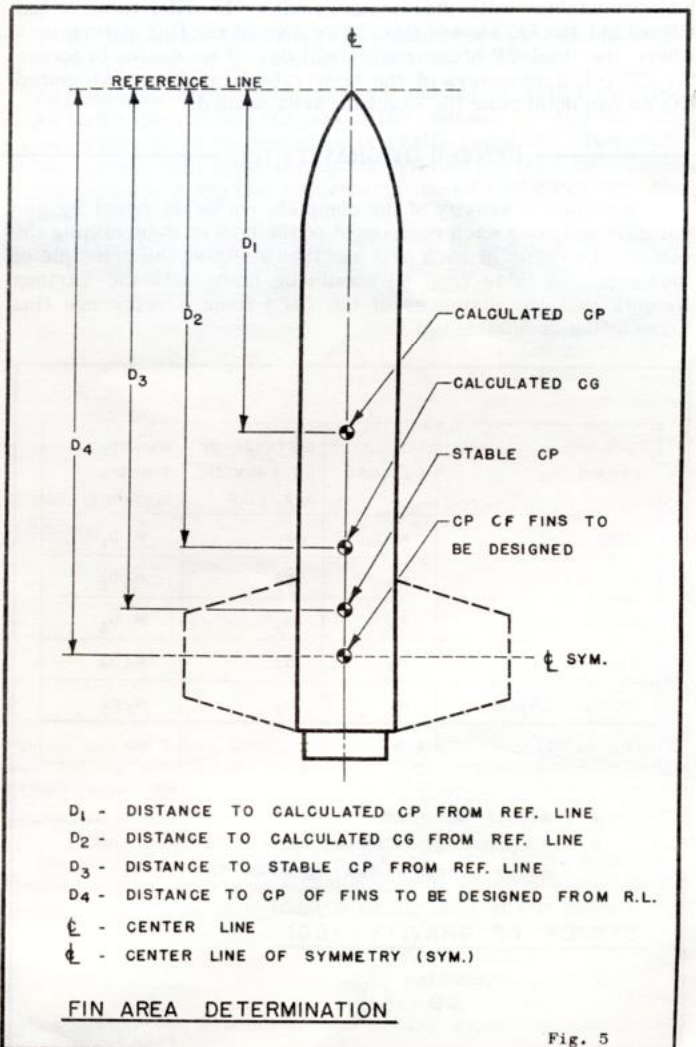

fin area becomes smaller. Consequently drag decreases and the rocket becomes lighter which increases its potential altitude.

The formula presented in fig. 6 is used to determine the necessary fin cross-sectional area. The example is given to show the method of finding the fin area when all other quantities are known. When the design has reached this step the values for  $\Sigma A$  and  $\Sigma AD$  will have been calculated and the CP and  $D_{CP}$  will have been decided. The only unknown quantity left is fin cross-sectional area which is found by the method shown.

$$CP = \frac{\Sigma AD + (D_{CP} \times A_{FIN})}{\Sigma A + A_{FIN}}$$

$\Sigma AD$  - SEE FIG. 4 FOR CALCULATED VALUE  
 $\Sigma A$  - SEE FIG. 4 FOR CALCULATED VALUE  
 $CP$  - DISTANCE FROM REF. LINE TO THE STABLE CP (FIG. 5), 1-1/2 DIAMETERS BEHIND THE CALCULATED CG (FIG. 2)  
 $D_{CP}$  - DISTANCE FROM REF. LINE TO THE DESIGN POINT FOR FIN CP  
 $A_{FIN}$  - AREA OF FINS

**EXAMPLE=**

$\Sigma A = 16\text{-IN.}^2$   
 $\Sigma AD = 64\text{-IN.}^3$   
 $D_{CP} = 7\text{-IN}$   
 $CP = 6\text{-IN}$   
 $A_{FIN} = \text{UNKNOWN}$

$$6 = \frac{64 + (7 \times A_{FIN})}{16 + A_{FIN}}$$

$$6(16 + A_{FIN}) = 64 + 7A_{FIN}$$

$$96 + 6A_{FIN} = 64 + 7A_{FIN}$$

$$96 - 64 = 7A_{FIN} + 6A_{FIN}$$

$$32 = A_{FIN}$$

**FIN AREA DETERMINATION** Fig. 6

The stable CP is located 1-1/2 body tube diameters behind the calculated CG because the fins with their slight weight will move the calculated CG to the rear of the rocket a small amount. The distance of 1-1/2 body tube diameters is sufficient to allow for this CG movement and maintain the stable CP at least 1 body tube diameter behind the final loaded rocket CG. If unusually large fins are used then a larger distance between calculated CG and stable CP must be used to allow for the greater weight of the fins. Most model rockets can be successfully designed by using the 1-1/2 body tube diameter distance.

FIN AREA DETERMINATION CONTINUED

The example in fig. 5 shows how to calculate the cross-sectional area required. If a four-finned rocket is designed then this calculated area must be divided by 2 for the area of one fin. If a three-finned rocket is desired, this calculated area must be divided by 1.5 for the area of one fin.

The final CG of the rocket can now be calculated. The method for doing this is exactly like the method shown in fig. 2. This time we add the total weight of all the fins and add this value in the column labeled WEIGHT. The total fin weight is then multiplied by the distance from the reference line to the CG of the fins and this product is put in the column labeled WEIGHT TIMES DISTANCE. Then, as before, we add up the weight of all items, this time including the weight of the fins, to get the WD sum-

mation. The WD summation is now divided by the W summation to yield the final CG distance from the reference line.

To be as accurate as possible the weight of the finish and the weight of the glue used can be included; however, this is not necessary unless you want extreme accuracy. If these weights are included, it is best to use the dry weights of the materials rather than the weights of the liquid material.

The final CG and CP are now calculated and the rocket should be stable in flight. To be certain that you have not made a mistake with your calculations you should check the rocket's stability after it has been built by tying a string around the model at its center of gravity and swinging it around in a circle. If the rocket is stable the nose cone will point straight ahead as it moves around. If, however, the rocket begins to rotate in circles around the string then **DON'T LAUNCH IT**. This will mean that your fins are too small and must be enlarged or moved farther back.

NOSE CONES

Figure 7 illustrates the graphical method to determine the CP of a nose cone. Measure the various diameters of the nose cone and plot them on a graph as shown. You will notice that the CP graph includes only the section of the nose cone that is exposed to the freestream in flight while the entire nose cone length is used in finding its CG.

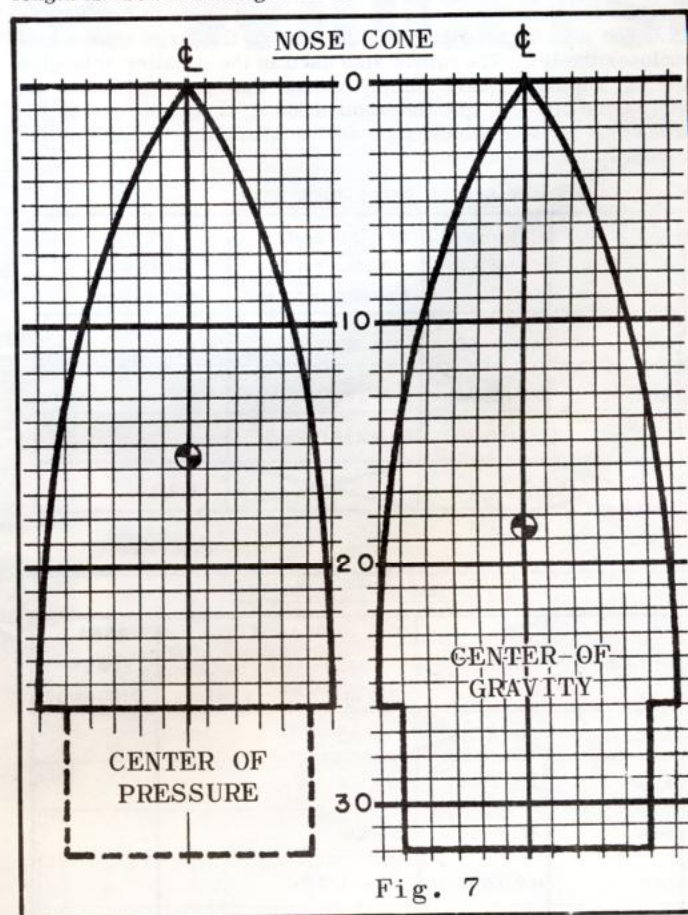

Each square shown is 1/10 inch long and 1/10 inch wide giving an area of 1/100 square inch. The cross-sectional area is found by counting the total number of squares enclosed. The total number of squares should be divided by 100 to give the area in square inches. The center of pressure will be at a point where exactly one half of the area is on each side of the line drawn perpendicular to the center line of the nose cone.

VARIOUS TYPES OF FINs

Figures 8 and 9 illustrate two of the most widely used types of fins. The illustrations and the following method for the solution of CP and CG may be used with any dimensions. The actual method of solution is illustrated below in fig. 8A and 9A. It

looks familiar, doesn't it? This principle of centroids and moments is very important in the design of rockets.

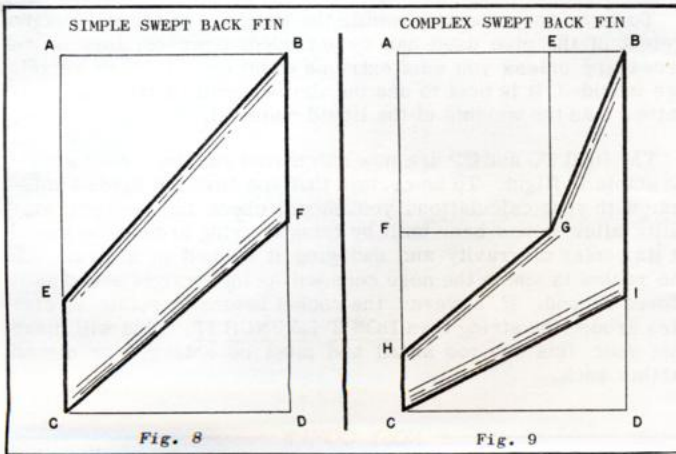

Figures 8A and 9A illustrate the tabular solution for the CP of the tail fins. The idea here is to find the CP of the square (ABCD) and then to subtract the CP of the smaller right triangles and the smaller square. This leaves the CP of the fin. The CP and CG of the fin are considered to be located at exactly the same spot so that when you calculate the fin CP you also have the fin CG. Notice the plus and minus signs in fig. 8A and 9A. The plus sign is used for the area of the large square that encloses the fin. The minus sign used in the smaller triangles and the smaller square simply means that these CP's are not part of the fin. To get the summation A, ( $\Sigma A$ ), add all of the areas that have a minus sign and subtract this total from the area with the plus sign.

**SIMPLE SWEEPED BACK FINS**

ITEM	AREA	CP DISTANCE FROM THE REFERENCE LINE	AREA TIMES DISTANCE
ABCD	$AB \times BD$ (+)	$1/2 BD$	(+)
ABE	$1/2(AB)(AE)$ (-)	$1/3 AE$	(-)
CDF	$1/2(CD)(DF)$ (-)	$BF + 2/3(DF)$	(-)
	$\Sigma A$		$\Sigma AD$

$$CP = \frac{\Sigma AD}{\Sigma A}$$

Fig. 8A

**COMPLEX SWEEPED BACK FINS**

ITEM	AREA	CP DISTANCE FROM THE REFERENCE LINE	AREA TIMES DISTANCE
ABCD	$AB \times BD$ (+)	$1/2 BD$	(+)
AEGF	$AE \times EG$ (-)	$1/2 AF$	(-)
BEG	$1/2(BE)(EG)$ (-)	$1/3 EG$	(-)
FGH	$1/2(FG)(GH)$ (-)	$AF + 1/3 FH$	(-)
CDI	$(DI)(CD) \frac{1}{2}$ (-)	$BI + 2/3 ID$	(-)
	$\Sigma A$		$\Sigma AD$

$$CP = \frac{\Sigma AD}{\Sigma A}$$

Fig. 9A

The column labeled AREA TIMES DISTANCE also has plus and minus signs. The moment will have a minus sign when the area, with a minus sign, is multiplied by a distance. To get the summation AD, ( $\Sigma AD$ ), add all of the terms that have a minus sign and subtract this total from the area with the plus sign. The summation A and the summation AD are substituted into the illustrated formula.

Figure 10 represents a tail design that can not practically be designed by the moment and centroid method. It requires the same type of procedure used on the nose cone. Count the total number of squares enclosed by the fin. The illustrated graph has ten lines to the inch which is 100 squares in 1 square inch. To get the area you simply divide the total number of squares by the number of squares in a square inch. (When you do this be certain how many lines to the inch your graph paper has. Many have 8 lines to the inch and some have 20.)

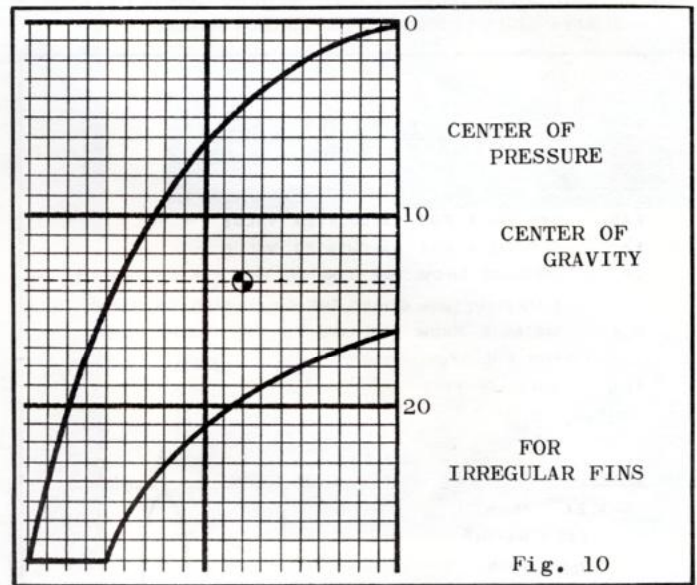

Fig. 10

The next step is to begin at the top of the fin and count the squares horizontally until you find out where exactly half of the area is. You will probably end up half way across a row of squares. To be very accurate make a note of the total number of squares in that row and also the number that you counted. For example, if there are a total of 15 squares in that horizontal row and you counted 5 squares before you came to half of the total area, then the CP will lie a distance of 5/15 or 1/3 between the two lines.

**REFERENCES:**

For a more detailed explanation of the principle of moments and centroids refer to the following books. There are illustrated problems worked in each of them.

**ENGINEERING MECHANICS**, 2nd Edition, by Ferdinand L. Singer, Chapter VII, Harper and Brothers, New York; 1954

**THEORY AND PROBLEMS OF ENGINEERING MECHANICS**, by W.G. McLean and E.W. Nelson, Chapter 9, Schaum Publishing Company; 1952

## AT LAST!

### A DEPENDABLE ELECTRICAL IGNITER!

### Easy 2-Step Installation



**1.**  
Bend and insert...  
No tricky coil to form!



**2.**  
Tamp in wadding

Uses less battery current!

ANOTHER ESTES FIRST!