

MODEL ROCKET NEWS

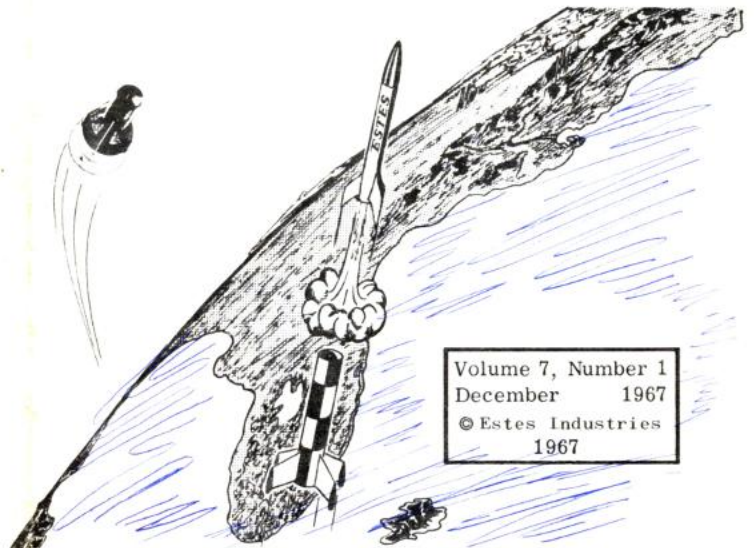

Volume 7, Number 1
December 1967
© Estes Industries
1967

NOSE CONES

• Designing • Turning • Finishing

Any rocketeer can produce countless different model designs using only factory-produced nose cones. Sooner or later, however, the serious model builder will find a design which requires a special nose cone size or shape. When this happens he should be ready to make his own.

It isn't hard to make a good nose cone—sometimes it's easier to get a good finish on a homemade cone than on a commercial one. The only major pieces of equipment required to produce good nose cones are a motorized drive and a patient modeler.

Homemade nose cones are formed by sanding them while they rotate. The nose cone stock must rotate rapidly both to form a round cone and to speed the shaping process. The motorized drive which rotates the cone can be a wood lathe, a machine lathe, a drill press, an electric hand drill or a surplus motor fitted with a chuck. Units such as electric drills which have regular drill-type chucks are usually best since the nose cone stock can be mounted on them very easily. Mount the drive unit securely on a solid object. An electric drill, for example, can be held in a vise or clamped to a workbench as shown.

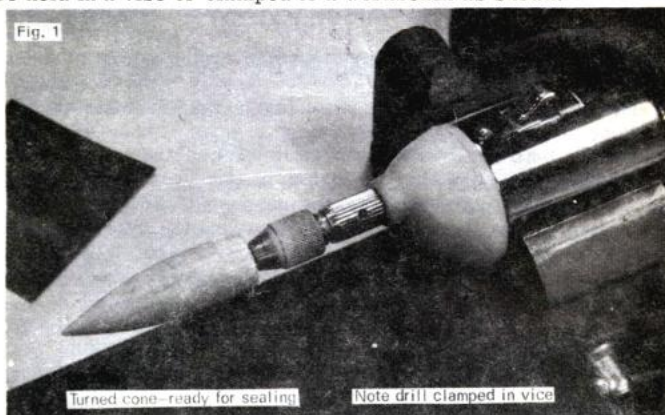

The best material for a nose cone is balsa wood. Hardwood is difficult to shape and presents a potential hazard in a model. Plastic foam will work, but is difficult to finish. Select a balsa block slightly larger than the final size of the nose cone. For example, if the cone is to be $3/4$ " diameter and 3" long, use a block at least 1" by 1" by $3-1/2$ " long. The grain of the wood should run in the same direction as the length of the nose cone.

Let's assume that you are going to make a 3" long nose cone for a BT-20 body tube. You will need a 1" square balsa block at least $3-1/2$ " long. To mount the block in the chuck, use a $1/4$ " diameter dowel about 2" long. (For blocks over 6" long it is best to use a piece of $3/8$ " or even $1/2$ " diameter dowel.)

Locate the exact center of one end of the block and mark it as shown in fig. 2. Drill a $1/4$ " diameter hole straight in, 1" deep, exactly on the mark. Squirt some glue into the hole and push the dowel into place. Set the unit aside to dry. If you have a wood lathe without a drill type chuck, get an experienced operator to help you mount your block.

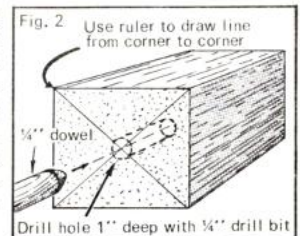

While the dowel is drying, draw a template (pattern) of the shape you want for the cone. Make the template on stiff paper and show the exact outline desired. Cut out the template, saving the outside portion. Next cut off a $1/4$ " to $1/2$ " long piece of the size body tube the nose cone is to fit. This piece of tube will be your guide in getting the right cone base diameter.

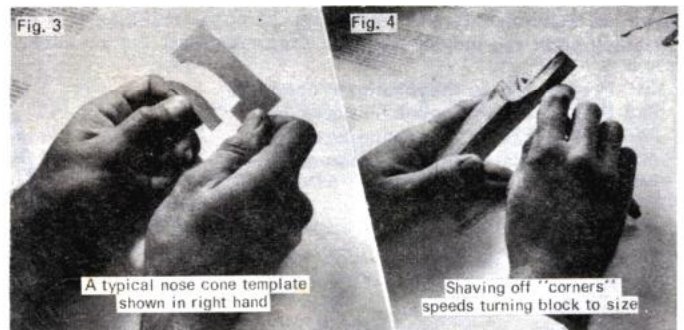

Once the dowel is completely dry, round the corners of the block with a knife as shown. Slip the body tube piece over the dowel, insert the dowel into the chuck as far as possible and tighten the chuck thoroughly. Once the block is mounted keep it in the chuck until the nose cone is completely finished.

Rotate the block manually a few times by turning the chuck (don't grab the block and force it). Look closely to see if the wood is well balanced around the centerline of the drive shaft. If the block is not balanced, trim slightly on the corner farthest from the centerline. Check again by turning the block and trim more if necessary.

Step off to one side and start the motor. If the block is too far out of balance it can fly loose. If you stand in front of it, it could hit you. If the block vibrates severely, stop the motor and trim more wood from the area farthest from the centerline. If it doesn't seem about to fly loose (and it won't, unless the hole was drilled quite crooked) the block is ready for shaping.

Continued on Page 3 . . .

Enter this Double-Header!

ESTES SCIENCE FAIR!

Did you use model rocketry in a science fair project this year? If so, we've got a special contest for you. To enter, just send photos of your exhibit, a general description of the project and a copy of your report to: Science Fair Contest, Box 227, Penrose, Colorado, 81240. If your project is picked as one of the best by the judges, you can win one of these great prizes.

- 1st Prize--\$50 in merchandise credit.
- 2nd Prize--\$25 in merchandise credit.
- 3rd Prize--\$10 in merchandise credit.
- 4th Prize--\$5 in merchandise credit.

— CONTEST RULES —

- 1) Each entry must include a photo of the exhibit as used in the actual science fair, a general description of the nature and extent of the project, a copy of the report used in the project and a statement signed by your teacher or parent certifying that the entry depicts the project as it actually was entered in the fair.
- 2) Entries must be postmarked no later than June 30, 1968.
- 3) Employees of Estes Industries and members of their immediate families are not eligible to enter this contest.
- 4) The decision of the judges is final.
- 5) All entries become the property of Estes Industries, Inc. No material will be returned.

NOTE: Prizes previously won by the project will not be considered in judging entries. However, the Editor would appreciate it if you would include such information.

Single Stage Design Contest

Design, build and test that single-stage bird you've been thinking about--it just might win you one of the many fine prizes we have listed below! Be sure to follow all of the rules as this will be a key point the judges will look for in deciding the winners.

- 1st Prize--\$50 in merchandise credit.
- 2nd Prize--\$25 in merchandise credit.
- 3rd Prize--\$10 in merchandise credit.
- 4th Prize--\$5 in merchandise credit.

1. Draw the plans to scale--ink drawings are recommended; pencil drawings are acceptable if neatly done.
2. Include a complete parts list.
3. Each entry must have sufficient construction information to allow the judges to build an exact duplicate of the original model.
4. All entries must have first been BUILT and TESTED, and must include an "in-flight" or "still" photograph of the entry.
5. Mail all entries to: Single-Stage Design Contest; Estes Industries, Inc., Box 227, Penrose, Colorado 81240. All entries must be postmarked no later than midnight, April 30, 1968.
6. The decision of the judges is final. All entries become the property of Estes Industries, Inc., and no material shall be returned.



PITTSBURGH CONVENTION

The Second Annual Spring Model Rocketry Convention, sponsored by the Steel City section of the N. A. R., was held at Shady Side Academy, Pittsburgh, Pennsylvania, March 17, 18 and 19, 1967. By Friday night, March 17th, 120 rocketeers from 10 East coast states had arrived at the academy site. Also attending were representatives of the National Aeronautics and Space Administration and Estes Industries.

The convention started officially Saturday morning with the keynote address by Vern Estes. His topic, "Mail Order Rocketry", included the fun and hard work of a mail order business illustrated with humorous letters received from customers.

After the address, the rocketeers formed discussion groups. A few of the topics were: basic model rocketry, advanced model rocketry and club formation. The groups encouraged each participant to relate his own model rocketry experiences so that others might learn.

After lunch, the convention members met at the athletic field for the launch session. Sub-freezing weather greeted the crowd that came to witness the launchings. Within 45 minutes, the cold had driven most spectators and many rocketeers to seek the warmer areas of the academy.

Among the added attractions at the convention was an exhibition of indoor model airplane flying by the Pittsburgh Aeromodeling Club. Another high point of the convention was the presentation by John Bannister, N.A.S.A. Spacemobile lecturer. Using models and aids, he provided an interesting program on the U. S. space effort.

When the convention closed at noon Sunday, each rocketeer returned home with the excitement of a successful model rocket convention, new friends gained, and knowledge of new and better methods and models.



MODEL ROCKET NEWS

The Model Rocket News is published by Estes Industries, Inc. Penrose, Colorado. It is distributed free of charge to all the company's mail order customers from whom a substantial order has been received within a period of one year. The Model Rocket News is distributed for the purpose of advertising and promoting a safe form of youth rocketry and for informing customers of new products and services available from Estes Industries. Rocketeers can contribute in several ways towards the publication of the Model Rocket News:

- (1) Write to Estes Industries concerning things you and your club are doing in this field which might be of interest to others.
- (2) Continue to support the company's development program by purchasing rocket supplies from Estes Industries, as it is only through this support that free services such as the Model Rocket News, rocket plans, etc., can be made available. This support also enables the company to develop new rocket kits, engines, etc.
- (3) Write to the company about their products and tell what you like, what you don't like, new ideas, suggestions, etc. Every letter will be read carefully, and every effort will be made to give a prompt, personal reply.

Vernon Estes
Publisher

Gene Street
Chief Illustrator

William Simon
Editor

NOTES FROM THE BOSS

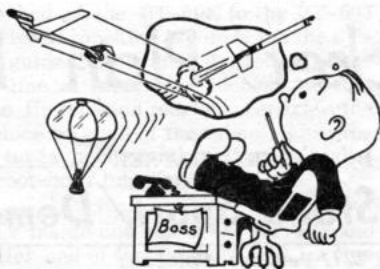

Model rocketry has a split personality today. Although most of America's rocketeers use English measurements (inches, pounds, yards, etc.), national and international model rocket contest rules and standards are written using the metric system (grams, meters, millimeters, etc.). The English unit of force is the pound, while the metric unit is the Newton. For example, a B.8-4 engine develops 1.12 pound-seconds total impulse. In the metric system, however, the same engine would have 5 Newton-seconds total impulse.

A nice, round figure like one pound-second converts to the uneven quantity of 4.45 Newton-seconds. Likewise one Newton-second equals 0.225 pound-seconds. As a result switching back and forth is inconvenient. If a rocketeer uses metric engine standards, he will probably find it easier to use the metric system for all his weights and measures. However, if he uses English measures for engine specifications, he might as well use the English system for measuring rocket length, weight and altitude. Most of the industrial world has already adopted the metric system for all measurements. Many of our scientists and engineers feel we should do the same.

This leads to the big question—which system do you, as a rocketeer, prefer? We'd like to hear your comments on the subject. If you'll write and let us know which system you prefer and why you prefer it, we'll publish the best letter from each side.

ENGINES

Over the last couple of months we've been changing some of our engines. The B and C engines are now being produced with a slightly larger inside diameter (1/2 inch) and give slightly higher average thrust. The total impulse for these engines is still the same, as are the outside dimensions of the engines.

The slight difference in engine design does not greatly affect the performance of most models. However, payload rockets and heavier models such as the Big Bertha, Thor Agena-B and Saturn will go slightly higher using the new engines.

This change is due to the addition of more engine manufacturing equipment. The new machinery gives better quality control, a more efficient engine and faster production. The most important result is that we will now be able to serve our customers better.

CLIPPINGS

Every day we receive newspaper clippings from all over the country telling about model rocketeers and their activities. We also receive some telling about basement bombers and their accidents. A good share of these clippings are sent in by rocketeers, and we appreciate your help very much.

These clippings are very valuable to us. Not only do they help keep us informed on the activities of the nation's modelers, but they are excellent for showing interested people how worthwhile model rocketry activities are. The clippings which show basement bomber accidents are valuable too. When a person who is about to perform a dangerous experiment reads a reprint of a clipping telling how someone else was injured or killed by the same experiment, he usually will change his mind.

We feel that the clippings rocketeers have sent us have won many friends for model rocketry and have saved quite a few lives. We would appreciate it if you'd keep on sending them. When you do send us a clipping, please include the line from the top of the page showing the name of the paper and the date it was printed. It's even more important, though, to have one other bit of information—your own name and address. Please write this on the back of the clipping so we can let you know we received it and thank you.

NOSE CONES . . . Continued from Page 1

Start with fine sandpaper, holding it as pictured. Touch it to the block near the front, then move it back and forth slowly until the corners are completely rounded. Stop the motor and slide the body tube ring up against the end of the block to see how much more balsa must be removed.

Sand carefully until the diameter of the block is between 1/8" and 1/16" larger than the outside of the tube. Once the block has reached this size, start cutting the shoulder. Sand the 1/2" of the block nearest the chuck with an emery board, stopping often to check the fit of the body tube ring against the shoulder section. Make sure the shoulder is straight and even. Sand very lightly as it gets close to the final diameter to avoid taking off too much balsa.

When the shoulder is down to the right size, the ring will just fit the shoulder. Leave the ring in place and start sanding from the tip end of the block, checking frequently with the template to find out where and how much balsa must be removed. When the block gets close to the final size and shape, switch to extra fine sandpaper such as the SP-320 sanding material.

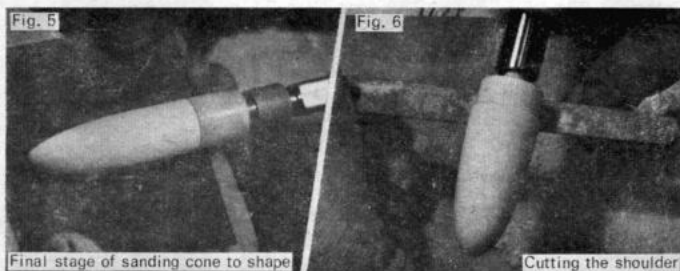

Once the cone is down to the final size and shape, turn the motor off. Leave the block in place in the chuck, slide the ring back and apply a coat of sanding sealer. Let it dry thoroughly. When the sealer is dry, turn the motor back on and sand lightly with finishing grade sandpaper (SP-320) until the cone is smooth. Stop the motor, apply another coat of sanding sealer, let dry and sand some more. Continue this operation until the grain is completely filled and the surface looks like plastic.

Paint can be either brushed on or sprayed. When spraying, cover the chuck and motor with a piece of paper first. Apply a light coat, let it dry completely, turn on the motor and sand very lightly. Continue applying light coats of paint, but do not sand after the surface is smooth.

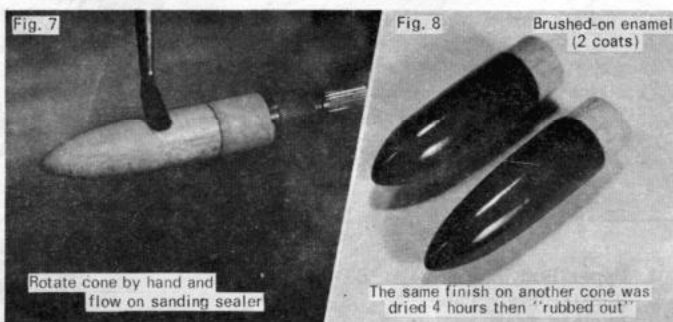

While the cone may be removed from the chuck at any time after it has been sealed, the best "mirror" finishes are obtained by leaving it on the machine and working it over with toothpaste or rubbing compound (available from most automobile supply stores) after the paint is completely dry. Work a small amount of paste or compound into a damp rag. Work the compound back and forth across the cone while the motor is running. Use a clean damp rag to remove loose material and excess compound from the surface, dry the cone and inspect it. When you are satisfied with the finish on the cone, remove it from the chuck, saw off the dowel and install it in your rocket. If fluorescent paint has been used, it must have several coats of clear spray over the paint before rubbing.

Don't expect your first nose cone to turn out perfect. While it might, it probably won't. The second one will be improved, the third even better. For sport models it's quite possible to get along without a template—in fact, it can be interesting to design the cone as you shape it. We've seen nose cones that look like dog bones, drum sticks, hats and doorknobs.

Estes Industries Rocket Plan No. 51

CHALLENGER

Designed By MARGIE PRATHER

Two-Stage Sport/Demonstration Bird

Published as a service to its customers by Estes Industries, Inc., Box 227, Penrose, Colorado

© Estes Industries 1967

Assembly

STEP 1. Glue a 2060 spacing ring to each end of two JT-60C couplers to start assembly of the engine mounts. Glue the EB-20A into one end of the BT-20J tube. Mark this tube $3/32''$ from the end which has the engine block. Mark the BT-20M tube $1/4''$ from one end. Let the ring-coupler assemblies dry before installing the engine tubes. When ready, install the tubes to the marks as shown.

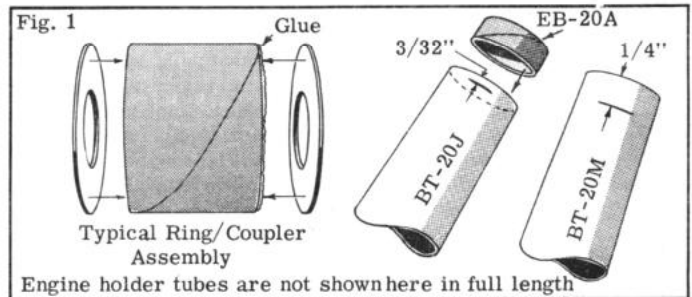

STEP 2. Trace the fin patterns onto heavy paper or card stock and carefully cut them out. Lay out three of each fin on the finstock. Cut out all fins and sand them smooth on the sides. All leading, tip and trailing edges are to be sanded round. Sand the root edges of all fins flat.

CUT-AWAY OF BODY TUBES AND RING/COUPLER ASSEMBLIES — SHOWS RELATIVE POSITION OF ENGINE TUBES AND TRANSTAGE COUPLER.

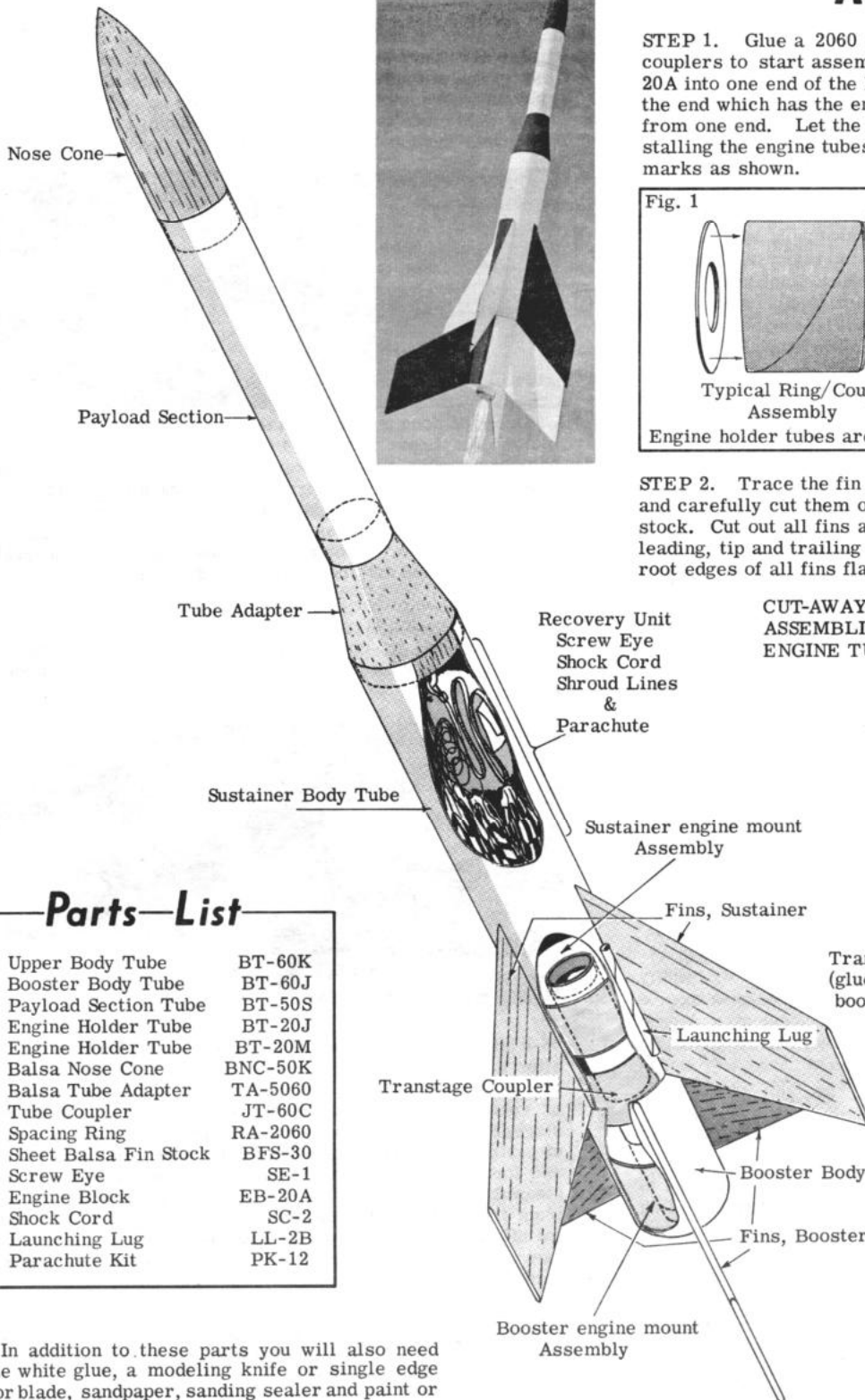
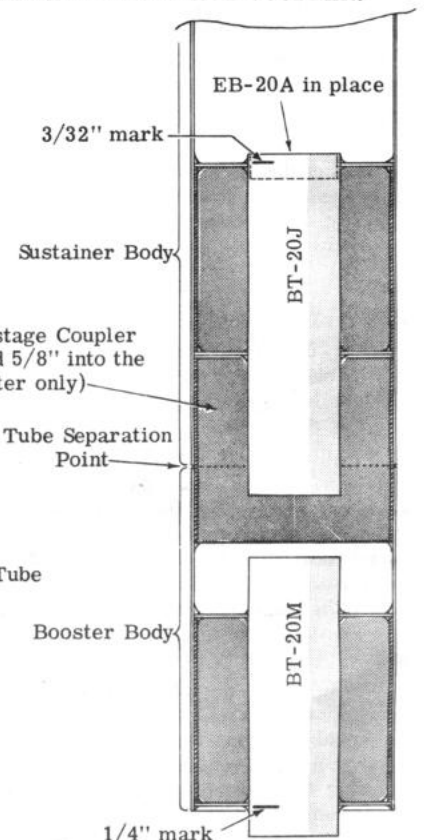

Parts List

1 Upper Body Tube	BT-60K
1 Booster Body Tube	BT-60J
1 Payload Section Tube	BT-50S
1 Engine Holder Tube	BT-20J
1 Engine Holder Tube	BT-20M
1 Balsa Nose Cone	BNC-50K
1 Balsa Tube Adapter	TA-5060
3 Tube Coupler	JT-60C
4 Spacing Ring	RA-2060
3 Sheet Balsa Fin Stock	BFS-30
1 Screw Eye	SE-1
1 Engine Block	EB-20A
1 Shock Cord	SC-2
1 Launching Lug	LL-2B
1 Parachute Kit	PK-12

In addition to these parts you will also need some white glue, a modeling knife or single edge razor blade, sandpaper, sanding sealer and paint or dope in the colors of your choice.

STEP 3. Carefully join one end of the BT-60K to the BT-60J tube with a couple of short strips of masking tape. Mark the BT-60J for three fins. Draw a guide line across the length of the BT-60J tube and extend the line at least four inches onto the longer tube from each of the fin location marks. Separate the tubes and glue the fins into place on each of the tubes. After the glue has dried, support the tubes horizontally and apply a glue fillet to each side of the fin root-body tube joint.

STEP 4. Apply a film of glue inside one end of the BT-50S and slide this end over the smaller end of the TA-5060. Put a line of glue around the joint and spread it smooth with a finger. Slip the BNC-50K into place on the other end of the BT-50S. Install the SE-1 as shown and lay the assembly aside to dry.

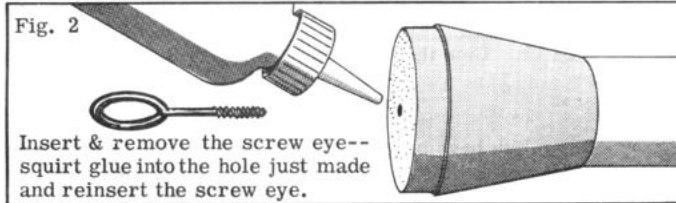

STEP 5. Assemble the parachute according to the instructions in the kit. Prepare a shock cord anchor as shown and install the unit inside the main body tube 1/2" from the forward end.

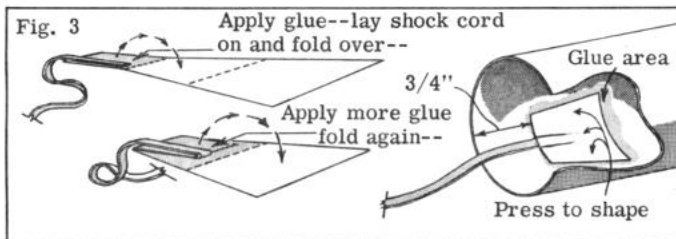

STEP 6. Apply a film of glue to the inside of the BT-60K main body tube over an area extending from 3/4" to 2-1/4" from the rear of the tube. Slide the engine holder unit with the longer tube into place, engine block end first, so the rear of the engine tube extends 1/4" beyond the rear of the main body tube. Install the other engine holder into the booster tube. Spread a film of glue for a depth of 1-1/4" inside the booster body from the rear. Pick up the engine holder unit by the end that has the 1/4" of the engine tube showing and slide the unit into the booster body from the rear. The ring-coupler is properly located when just 1/16" of the inside of the booster is showing. Apply a fillet of glue to this ring-tube joint and set the whole assembly aside to dry.

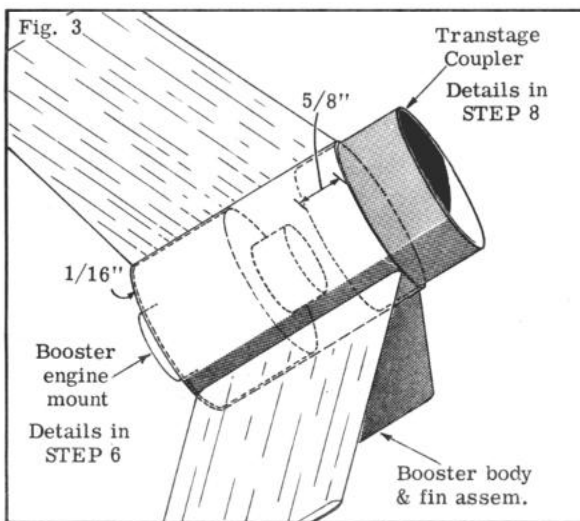

Trace the patterns onto cereal-box board to make a template of each.

STEP 7. Tie the shroud lines and free end of the shock cord to the screw eye of the payload section. Pack the chute into place and slip the payload section into place. Sand both coupler and nose cone smooth, particularly the tube-coupler and tube-nose cone joints, until there is a smooth transition from one to the other. Your upper stage is ready to finish in the colors of your choice.

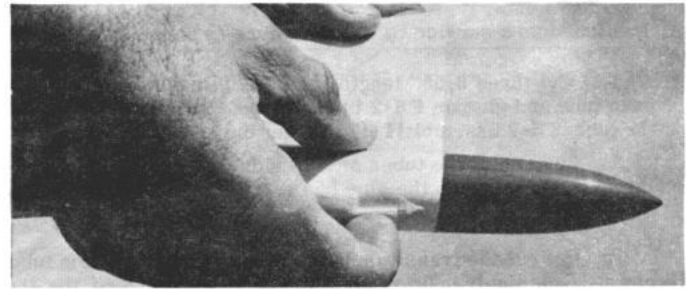

STEP 8. Mark the remaining JT-60C at 5/8" from one end. Apply a film of glue to the inside of the front end of the booster assembly and slip the JT-60C into place 5/8" into the booster. Align this piece carefully to assure a true coupling to the upper stage. The booster is now ready to finish to compliment the upper stage.

GENERAL ENGINE RECOMMENDATIONS

Including the booster, this bird weighs 2.18 ounces allowing up to 3-ounce payloads using Series II engines. For sports and demonstration flying (no payload) the Challenger has performed properly with as little as a 1/4A.8-0, 1/4A.8-4 Series I engine pair. Use B engine pairs for flying the average (1-2 ounce) research payload.

Fin Patterns

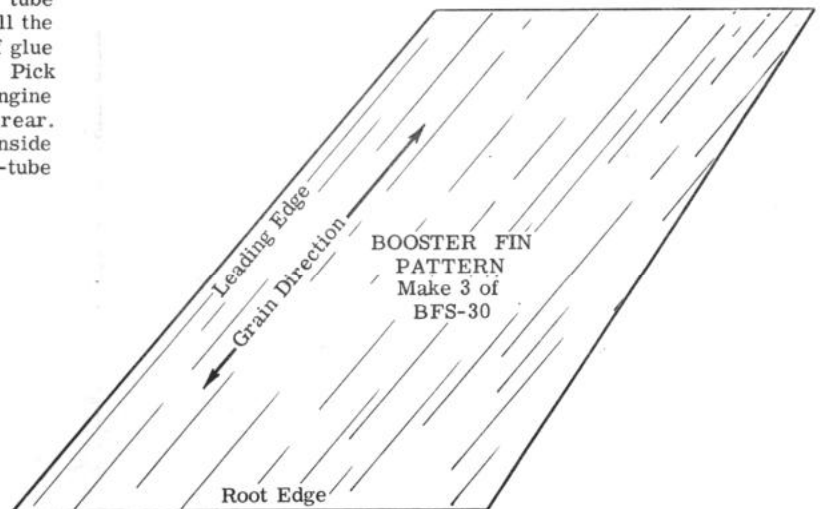

See STEP 2 for fin preparation.

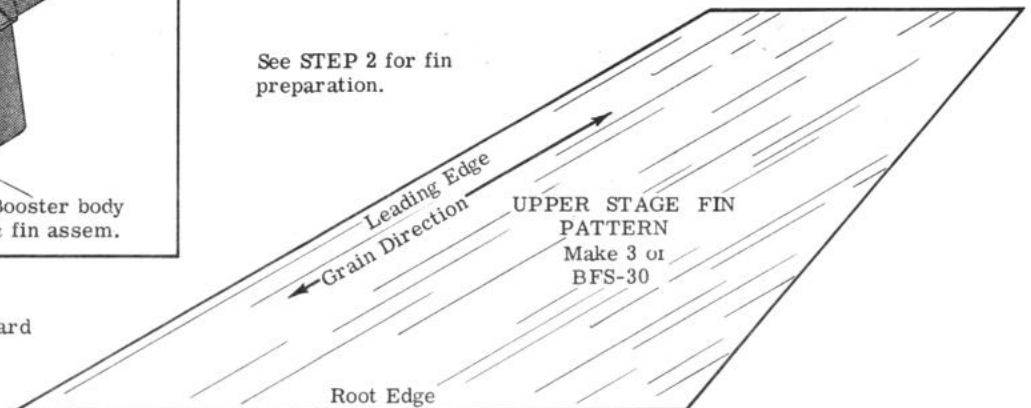

Estes Industries Rocket Plan No. 52

JAGUAR JGD-2

3-ENGINE CLUSTER
'CHUTE RECOVERED!

Published as a service to its customers by Estes Industries, Inc., Box 227, Penrose, Colo. 81240 © Estes Industries 1967

1. Cut three 8.55" lengths of BT-20, make a slit 2-1/2" from the end of each tube and glue an EH-2 in each tube. Wrap a 2-1/2" strip of TH-1 around the tube/EH-2 assembly 1-1/4" from the end of each tube.
2. Lay two of the tubes side by side on a flat surface and join with a heavy layer of glue. When the glue has set, glue the third tube into the "V" formed by the first two tubes.
3. Cut out the transition base plate and the transition tubes using the template. Glue the transition plate to the forward end of the three-tube engine assembly. Glue the flat edges of the transition tubes together. Let this assembly dry, then run a glue fillet on the inside of each joint.
4. Glue the tube assembly to the transition plate, center the assembly very carefully and let dry. Run a glue fillet on the inside of the tube-plate joint.
5. Put glue on the end of the long tabs of the second stage body tube and insert into the hole in the top of the transition, making sure that the tabs seat between the holes in the plate. Run a line of glue around the top of the transition and let dry.
6. Cut out the transition shroud and glue together. When the shroud is dry, slide it into place over the transition. Lightly mark the joint made by the shroud and transition -- slide the shroud back and run a thin line of glue around the joint line and slide the shroud into place. Run a thin fillet of glue around the joint at the top end of the shroud and smooth out with a finger. Set the assembly aside to dry thoroughly.
7. Cut a 3.63" length of BT-5 and glue to the TA-520. Make a nose cone (as shown in the upper right side of the plans) and glue into the forward end of the BT-5.
8. Cut out the engine shroud and glue together. When it has dried, slide the shroud into place on the rear of the rocket. Fit the rear edge of the shroud flush with the rear edges of the engine tubes.
9. Trace the fin root and tip formers onto heavy cardboard for a template or trace directly onto a sheet of BFS-40. Repeat this step with the fin brace pattern, but if traced directly to wood, make the brace pieces of BFS-20. Cut three pieces of BFS-40 2" x .15" for the trailing edges of the fins. Assemble the fins and glue into place on the lower shroud.

10. Assemble the parachute following the instructions in the kit. Install the screw eye in the bottom of the TA-520 in the usual way. Assemble a shock cord mount and install the shock cord at least 5/8" deep into the top end of the rocket. Tie the free end of the shock cord and the free ends of the shroud lines to the screw eye and your Jaguar's recovery system is complete.
11. Glue the launching lugs into place at the locations shown on the plans.

GENERAL INFORMATION

If you have built and flown the Astron Ranger or the Astron Cobra you will have no problem in preparing the Jaguar for flight. If this is your first cluster bird, it will be to your benefit to prepare the "whip" shown in the picture. An alternative method is shown in the Idea Box page of M. R. N. Vol. 6, #1.

Recommended engines; 1 1/2A, 8-2, A, 8-3 B 8-4, B 8-6.

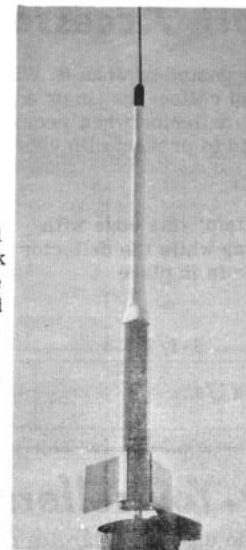
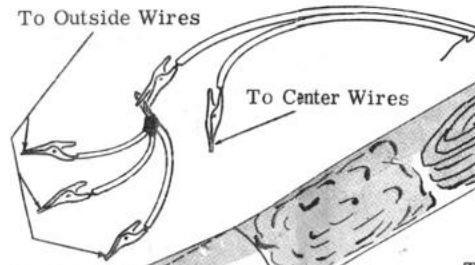
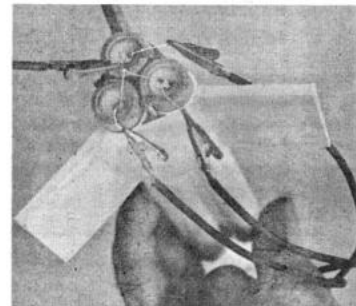

T-MINUS 5... and COUNTING!

ABOUT THIS BIRD

The Jaguar is an air launched rocket designed to gather data on the natural radiation belts surrounding the earth.

A three stage sounding rocket, the Jaguar consists of a cluster of three recruit motors in the first stage a single recruit motor as a second stage, and a fifth scale Sergeant as a third stage.

A U. S. Air Force project, the Jaguar is launched from B-47 aircraft on a pull-up into a near vertical position.

Length, ft: 29
Diameter, in: 15
Weight, lb:
Loaded: 1,700
Payload: 35
Altitude, miles: 500-600

Reference;
International Missile and Spacecraft Guide.

T + .0042 Sec.
and LIFTING!

Parts List	
1	Balancing Weight NCW-3
3	Engine Holders EH-2
1	Sheet Fin Stock BFS-40
1	Launching Lug LL-2B
1	Tube Adapter TA-520
4	Body Tubes BT-20
1	Body Tube BT-5
1	Screw Eye SE-1
1	Shock Cord SC-1
1	Parachute PK-12
3	Tape Hinges TH-1

BNC-5V Can be turned down to make nose cone.



Nose Cone template

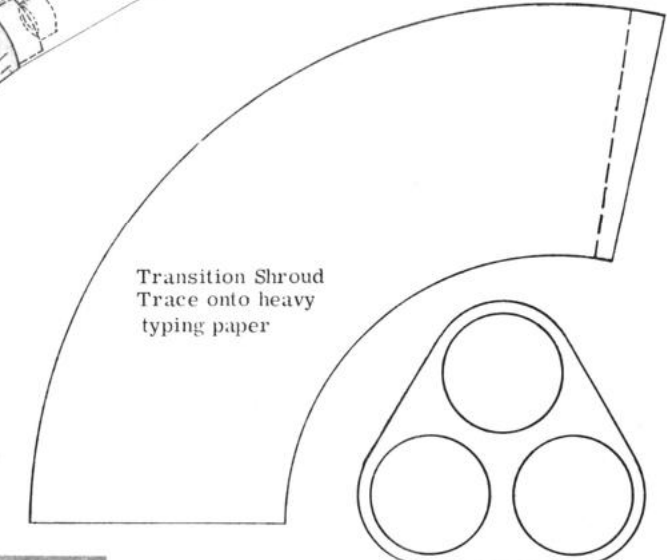

Transition Shroud Trace onto heavy typing paper

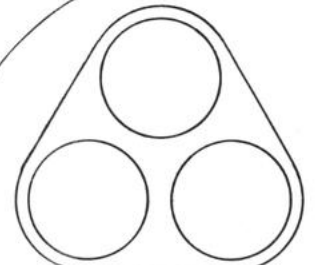

Transition Plate (Card stock)

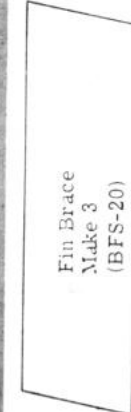

Fin Brace Make 3 (BFS-20)

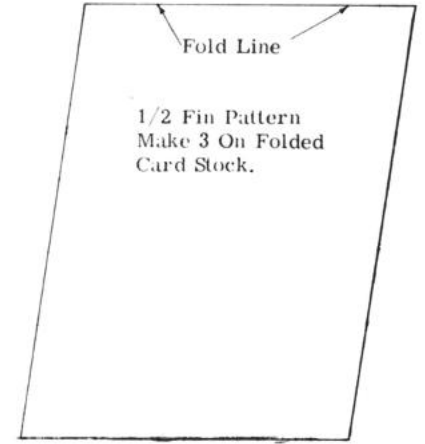

1/2 Fin Pattern Make 3 On Folded Card Stock.

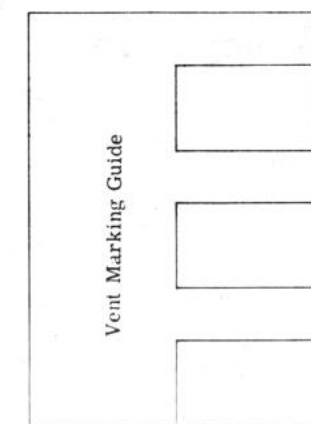
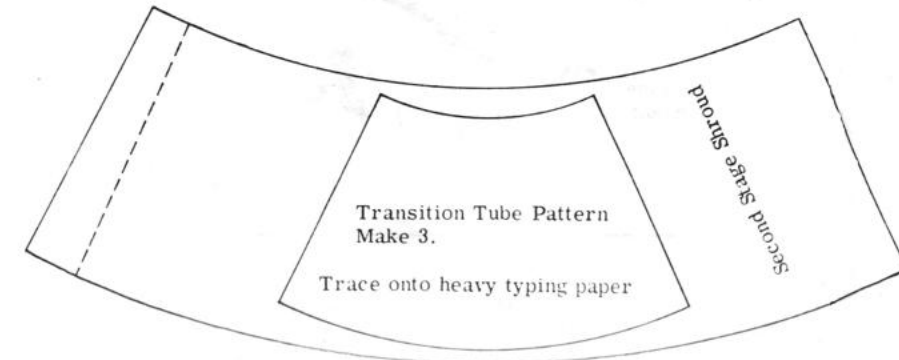
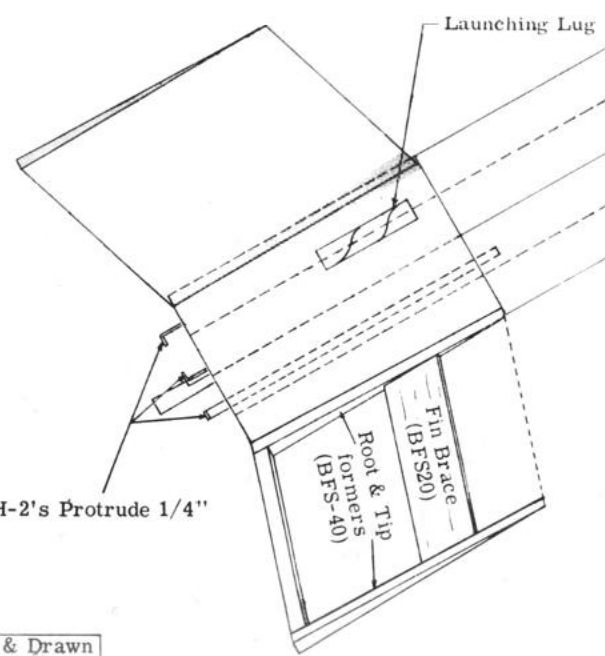
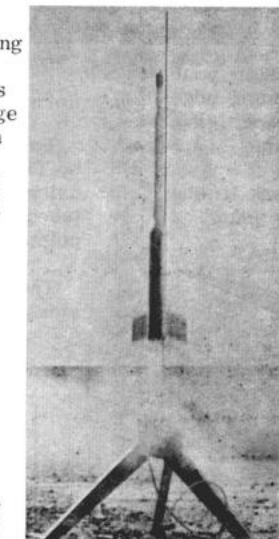

Vent Marking Guide

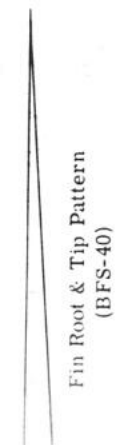

Fin Root & Tip Pattern (BFS-40)

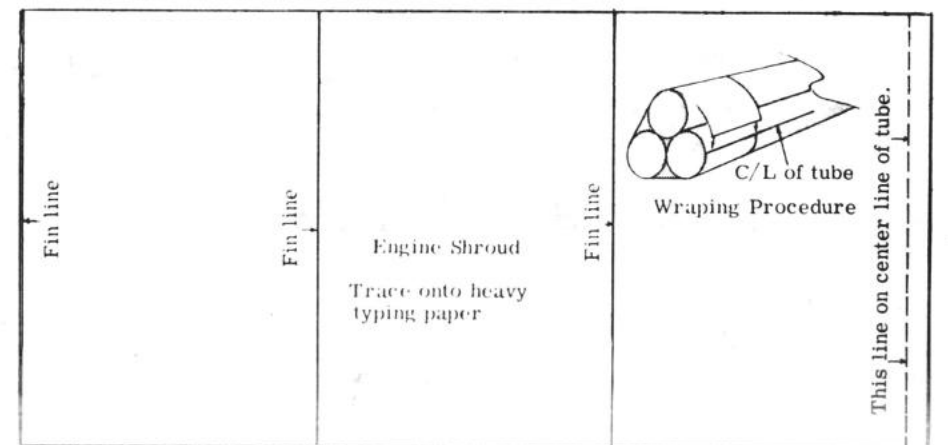

Engine Shroud Trace onto heavy typing paper

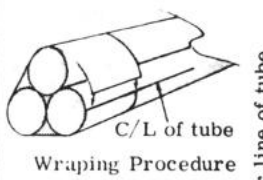

C/L of tube Wrapping Procedure

Scaled & Drawn By: [Signature]

The Idea Box

Built-up Fins ... They Work!

Yes, in some applications, fins made of shroud or pattern sheet material may be easier to make and finish than a set made from balsa or birch sheet stock. This type of fin construction is especially good for most scale fins, including those which have one or more "knife edges" around their perimeter.

Step 1. Visualize the fin shape as though you could see through it. Most "big bird" fins are built up and have rivet lines, metal "skin" joints or definite angle changes in the surface. Take a tip from the engineers and use such features as a help in deciding where the support framework should be placed for fin shape and strength.

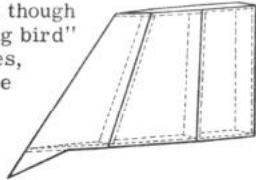

Step 2. Material for the frame may be hard balsa, or a tongue depressor or stir-stick. Measure carefully and lay out the necessary pieces with the grain of the wood as seen. Cut them from the stock with a razor-saw or knife and straightedge. It is best to dry-fit all parts over your fin drawing to make sure all cut parts are of proper shape and size.



Step 3. Fold the shroud or pattern stock in half and start your layout of the fin outline, using the fold edge as the leading edge of the fin. After drawing the first fin outline, cut it out and, leaving it folded, use it as the pattern for the rest of the fins.

Step 4. Unfold one fin "skin" and glue the framework to one side as shown. Remember, you are gluing paper to wood... a small amount holds fine. (Too much glue tends to shrink and will distort the outer surface.)

Apply a thin film of glue to the framework (and to the tip and trailing edge of the "skin" too, if your fin is the type with the knife edges in these positions) and press this last half of the "skin" into place. Hold the assembly until the glue has set. Proceed with the remaining number of fins you have to prepare.

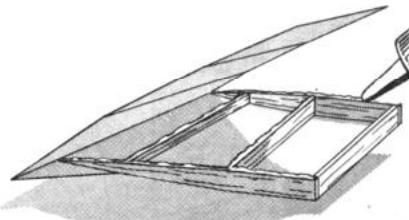

It looks easy... and is easy, once you get the "hang" of it... but practice on a few fins first, before starting on the fins that are to grace your "pride and joy". (Tweezers will come in very handy as some of your framing parts may be quite small.)

Quick Launch Aid in the Field

So many of you have sent in this suggestion that it would be impossible to recognize one individual as the author. So, for those of you who are not already using the idea, or who do not wish to make the gadget shown elsewhere on this page, here is a quickly prepared rocket stand-off. Just ream out the nozzle end of an expended engine (with the end of your launch rod, if you are in the field and no other tool is available) and slide it down the rod to the blast deflector. Your bird is automatically held off the pad a distance of 2-3/4".

A Rocket Stand-off Accessory

You can make this handy gadget, suggested by John H. Whitby, of Salt Lake City, Utah, using a strip of coffee-can tin or a piece of aluminum, clipping it to your blast-deflector when necessary to support your bird away from the pad to prevent clip shorting.

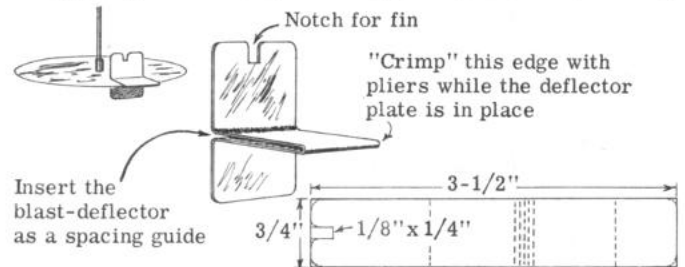

For Camroc "Do-It-Yourselfers"

Here's how Jim Trame of Lima, Ohio made an enlarging mask that allows full diameter enlargements of his Camroc negatives.

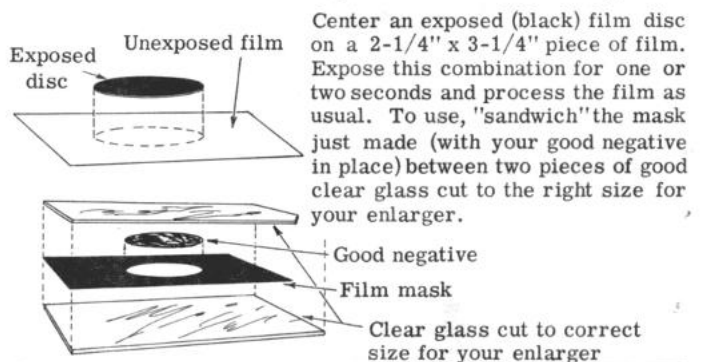

Handy Tube-sizing Gauge

Positively identify your body tubes with this device suggested by Tim Hines of Toledo, Ohio. The gauge is easy to calibrate, using the tubes you probably have on hand---just insert the body tube into the open end as shown and mark the gauge arms at both points of contact, labeling this set of marks on the upper arm.

The original gauge was cut from 1/2" plywood to the dimensions shown.

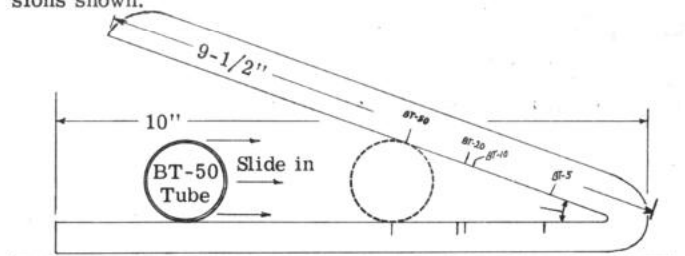

Clip-On Launching Lug

You can do a perfect scale job on a bird which is normally not equipped with launching lugs, and still fly it with regular launch systems, thanks to this clip-on launching lug suggested by Ed Brown of Florence, Colo., and of Estes' Machine Shop crew.

Select a piece of body tube of the same diameter of your bird and slit it as shown. Glue a launching lug on the outside opposite the slit. When ready to fly, just slide the unit to the C/G of your bird and prepare to launch as usual.

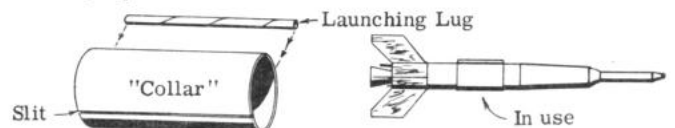

Estes Industries Technical Report No. TR-6

Cluster Techniques

These reports are published as a service to its customers by Estes Industries, Inc., Box 227, Penrose, Colorado 81240.
Copyright 1967 by Estes Industries, Inc.

INTRODUCTION

One of the most common and valuable techniques in the development of launch vehicles to boost large payloads is the use of several engines in a cluster to provide enough thrust for first stage lift-off and acceleration. Typical clustered launch vehicles include NASA's Little Joe, Saturn I and Saturn V.

In professional rocketry clustering makes it possible to combine several smaller, less expensive and more reliable rocket engines to boost the payload. If a single larger engine were to be used in a new launch vehicle design there could be a delay of several years before the engine can be developed, resulting in a vastly greater cost.

Model rocketeers can get many of these same advantages by using clusters in their vehicles. Many of the problems a model builder will encounter are similar to those met by professionals.

CLUSTER ROCKET DESIGN ENGINE ARRANGEMENTS

It is common when clusters are mentioned to immediately think of three or four engines set in some arrangement that will allow them to all fit in a round body tube. Actually, any arrangement of two or more engines in the same stage of a model can be considered a cluster. Generally, four engines are the most that should be used in a model rocket, since more engines make ignition less reliable. Some typical arrangements are shown in Fig. 1.

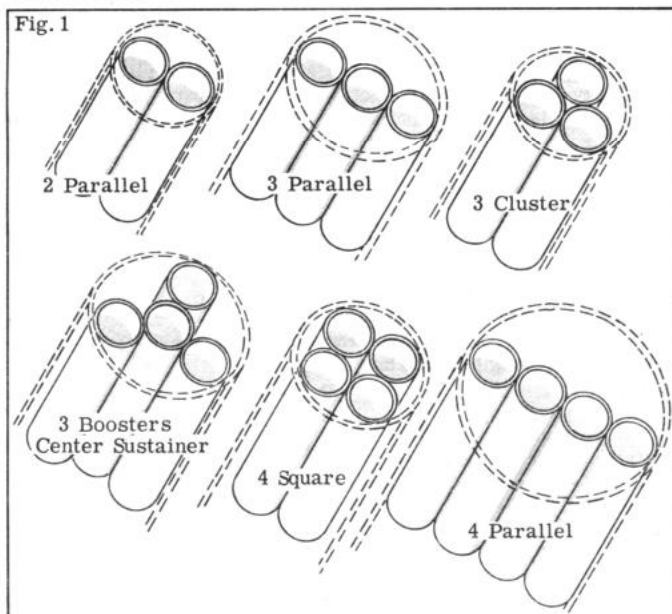

In designing a cluster rocket first make sure that thrust will be balanced around the center line of the rocket. An unbalanced arrangement will normally cause the rocket to veer off course. Similarly, all engines located away from the centerline of the rocket should develop the same amount of thrust. For example, the two outer engines in a parallel 3 engine cluster must be the same--although the center engine might be a B. 8-4, if one outer engine is a B 3-5, the other one must be a B 3-5.

All engines should be located fairly close together. Avoid wayout designs with the engines spaced several inches apart. The distance from the center of the nozzle of one engine in a cluster to the center of the nozzle of any other engine in the cluster should not be more than 10% of the rocket's length. It is better to keep the engines positioned so they almost touch each other. If this is done variations in thrust will not make the rocket veer off course.

Unusual engine arrangements should be developed carefully. Check to be sure the thrust from all engines will balance. A slight amount of imbalance or misalignment can be offset by using extra large fins or a small amount of spin angle on the fins. If thrust is very far out of balance, however, the rocket will not fly straight enough to be safe.

ENGINE MOUNTING

Once the basic engine arrangement for a cluster model has been chosen, the next step is to design an engine mounting system. The engine mounting system serves three purposes: First it should hold the engines securely in place throughout the flight. Second, it should align the engines so they work together as a unit and give a straight flight in the desired direction. Finally, the engine mounting system must seal the rear of the rocket so that the recovery system ejection gases cannot leak out through cracks and holes in the back of the model.

The first item to consider in designing the engine mounting system for a new model is a method for retaining the engines. They can be held in place either with masking tape or engine holders (#EH-2 or #EH-3). Masking tape (which is wrapped around the engine to make it fit tightly in the mounting tube) has the advantages of lighter weight and lower initial cost. On the other hand, engine holders do not weigh much more, allow quick and easy replacement of engines, and are positive--once the engine is in place it is held securely and won't come out until it is intentionally removed.

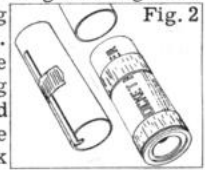
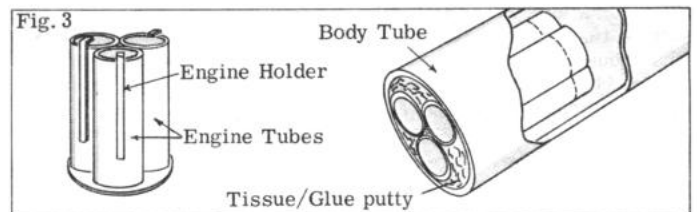
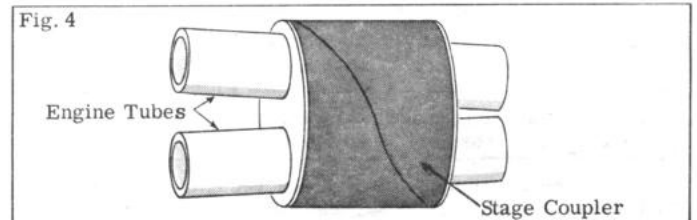

Figure 3 shows typical engine mounting systems for a three engine model. Note that when engine holders are used, the spaces between tubes are sealed at the front of the engine mounting tubes, while when masking tape is to be used to secure the engine in place the spaces can be sealed at the extreme rear of the rocket. The same considerations apply to any other cluster model, regardless of the number of engines it uses.



If a body tube is large enough to hold three engines, it can also hold two engines. Figure 4 illustrates techniques which



can be used to position and align engine mounting tubes which would otherwise fit too loosely in the rocket body tube. When it is necessary to make special rings to position and support the tubes, the rings should be cut from fairly heavy cardboard such as is used in shoe boxes. An Estes #KNS-1 knife, wrapped with three or four layers of masking tape and mounted in an ordinary school compass, makes an excellent tool for cutting the rings.

Occasionally it is desirable to mount several engines in a body that would normally be too small. A good example of this would be the use of two engines in a model with a BT-55 body tube. In this case slots should be cut in the body. Each slot should be the same length as an engine mounting tube and just wide enough to let the mounting tubes stick out the same amount on each side of the body. Figure 5 shows a typical rocket built in this way. The cut-out pieces of body tube can be trimmed to make fairings for a smooth transition from the body to the projecting engine mounting tubes. A fairing can also be made by cutting a nose cone in half and carefully carving and sanding the halves until they fit smoothly in place.

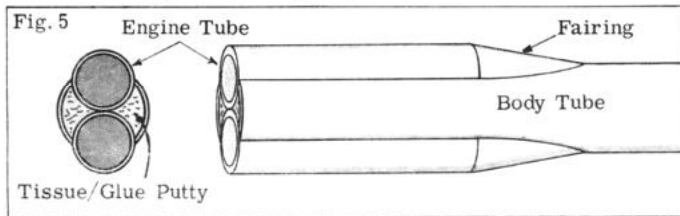

From these examples it can be seen that there are countless ways of mounting engines. As long as the engines are held in alignment, the rear of the model is sealed to prevent ejection gas leakage and a path is provided for the ejection gas to blow forward, just about any system will work. In any case, the engine mounts must be strong enough to stand up to the engines' maximum thrust. The best way to make sure the engine mounting system will be strong enough is to use plenty of glue when building it.

STABILITY

Because the weight of several engines is concentrated in the rear of a cluster rocket, extra attention should be given to designing the rocket so it is stable. Since the engines will not always all be producing exactly the same amount of thrust at the same time, an extra margin of stability is needed. A good cluster model will have extra-large fins. These fins should be located well to the rear on the body--fins ahead of the model's center of gravity (balance point) should be avoided since they make the model less stable.

It's easier to stabilize a tall rocket than a short one. Since body tubes are relatively light, there's no real reason to use too short a tube. In general, a two or three engine model should use a body between 15" and 24" long. If the model carries a payload it should be located near the very front of the rocket. This forward payload weight, combined with a long body, brings the center of gravity forward and increases the model's stability.*

Since a cluster rocket will usually be heavier than a single engine model, it is apt to land harder. In addition, the forces acting on a cluster model's fins in flight are greater. The result is that the cluster model will need extra strong fins. Big fins should be made stronger than small fins. Because of this one-eighth inch thick balsa sheet is the most popular fin material for cluster birds.

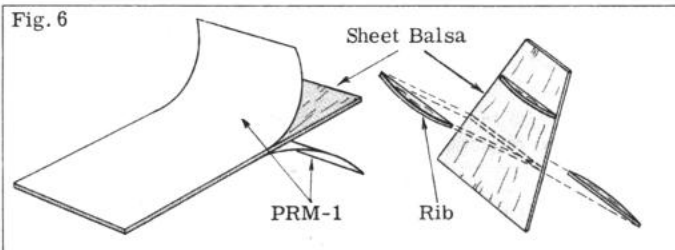

Fin stock thinner than 1/8" can be used, but it should be reinforced for best results. Two reinforcing methods are com-

*For more information on stability, see Technical Report #TR-1 and Technical Report #TR-9. These reports may be ordered at \$.25 each.

monly used: Self-adhesive paper (#PRM-1) can be applied to both sides of the fin or strengthening ribs can be glued to the fin, parallel to the root edge and spaced evenly along the fin as shown in figure 6.

A small amount of spin can be useful with cluster rockets. Slightly off-center thrust can be evened out if the rocket spins slowly. However, too much spin will waste thrust since drag on the rocket increases as the rocket spins faster. One way to give the rocket the right amount of spin is to glue the fins to the body at a slight angle. A non-symmetrical airfoil on fins that are straight on the body will also produce enough spin. Finally, a small angled "spin tab" can be added near the tip of each fin. In any case, make sure all fins or tabs are made to spin the rocket in the same direction.

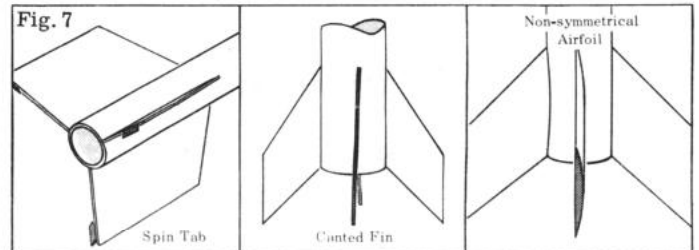

It can be mighty embarrassing to lead all your friends in a grand procession out to the launch pad for the maiden voyage of your "super" bird if that bird decides to go up 50 feet and then loop around in the air. To avoid this embarrassment (and to insure safety) TEST IT BEFORE YOU FLY IT. Use either a wind tunnel or the string method described in Technical Report TR-1 to make sure the model will be stable. If the model is tested by the string method it should have at least a 15° to 20° "margin" of stability. If the rocket is not stable you can either make it longer, add nose cone weights or install larger fins.

RECOVERY

Since a cluster rocket is usually larger and heavier than a conventional rocket, its recovery system must be designed to handle a greater load. Parachute recovery is the only system which has actually proven practical for cluster rockets. Generally, two parachutes are used on models with large payload sections; rockets with small payload sections often need only one parachute. Some designs, however, may require three or even four 'chutes. A good rule to follow is to provide at least 40 square inches of parachute area for each ounce of rocket weight.

There is a reason for using at least two 'chutes on a model with a large or delicate payload section. This eliminates the possibility of the payload section snapping back on the shock cord after ejection and damaging the rocket or payload. The parachute on the payload section can be attached directly to a lightweight payload section. For heavy or delicate payloads, however, a short length of shock cord should be used to connect the 'chute to the payload section. The booster section's 'chute should be attached with a 1/4" wide shock cord at least 18" long (part #SC-2).

Additional steps can be taken to improve a cluster rocket's recovery system. A "stuffer" tube can be used in a long booster body to control the ejection gases and to keep the parachute from moving too far rearward in the body. The stuffer tube can be a section of either BT-20 or BT-50, centered and held in place in the body with two rings as shown in figure 8.

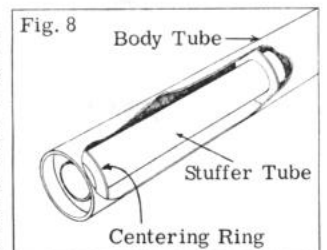

To reduce fin breakage the recovery system can be attached to the outside rear of the body instead of the front. This is done by gluing one end of a string in a hole in the body about one inch from the rear. The other end of the string is tied to the shock cord. The string should be long enough to reach up the side of the body tube and back two or three inches into the inside of the body tube.

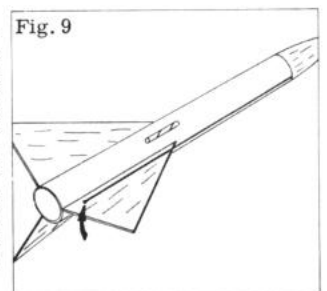

The best way to protect parachutes from the heat of ejection gases is to use an adequate amount of flameproof wadding. Use enough loosely packed wadding to fill the body for at least twice the diameter of the tube. Stuff the wadding into the tube just far enough to allow space for the parachutes, shroud lines and nose cone. Don't push the wadding all the way to the rear of the tube.

MULTI-STAGING

Clustering can be combined with multi-staging only under special circumstances. Certain rules must be followed if the rocket is to be either safe or successful. The first rule is that only the first stage can be clustered. To understand the reason behind this, remember that each engine in a multi-stage model rocket must be coupled directly to the engine ahead of it. However, if three engines in one cluster stage are each coupled to engines in another cluster stage, one booster engine will burn through a tiny fraction of a second before the others. This variation in time is enough to force the stages apart before the other two engines can ignite.

As a result, the only successfully proven staged and clustered system uses a bottom stage which has one engine in the center and two or three engines alongside it. This center engine is coupled directly to the single engine of the next stage. The outside engines can be placed in pods with a streamer or parachute recovery system to return the booster gently. In this case the outside engines should have short delays (B. 8-2).

Fig. 10

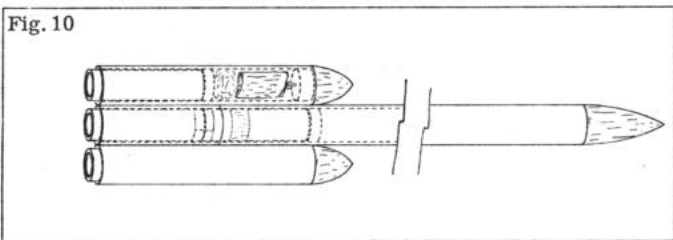

IGNITION

Ignition is the most important part of successful clustering. All engines must ignite at once or within a tiny fraction of a second of each other. Many techniques have been tried to obtain successful ignition. Some methods proved unreliable, others were also unsafe. The only system which has proven safe and reliable through extensive testing is direct electrical ignition using standard igniters.

Five things are necessary for successful electrical ignition: The correct engines must be used; the igniters must be installed in the engines correctly; the igniters must be connected together correctly; the electrical launching system must be in good condition with good connections throughout and the launcher battery must have enough power. If there is a flaw in any of these five areas, ignition will not be completely successful. If everything is done correctly, all engines will ignite at the same instant and the rocket will roar skyward.

TYPES OF ENGINES

Since the usual purpose of clustering is to boost a payload to a greater altitude than would be possible with a single engine, it is usually necessary to use A or B class engines. A single engine rocket using a B 3-5 engine will normally lift a payload higher than a cluster rocket with four 1/2A. 8-2 engines. However, 1/2A or smaller engines can be useful for the first test flights of a lightweight cluster model.

To decide which engines are best for a rocket, divide its total weight (including payload and engines) by the number of engines it uses. Compare the result with the "maximum rocket weight" listed in the engine selection chart in your catalog to find which engines can be used. For a more accurate choice of engines, read Technical Report #TR-10 (50¢ per copy). The method described on page four of the report gives good results. Careful selection of engines can prevent damage to the rocket which might occur from too early or late ejection.

NOTE: Before installing the engines in your cluster rocket, pack the front of the engine above the ejection end cap with flame-proof wadding. This eliminates any possibility of one engine's ejection charge igniting the ejection charge of another engine and damaging the rocket. This is extremely important when one engine in a cluster fails to ignite at lift-off.

INSTALLING THE IGNITERS

For direct electrical ignition the igniters in the individual engines must be installed correctly. Before starting, read the instructions which come with your Estes engines. Several points should be remembered when installing igniters; First, the igniter must be inserted so its coating touches the black propellant grain. The bent end of the igniter should reach at least 9/16" into the end of the engine. The heat generated by the igniter is not great enough to cross a gap between the igniter and the propellant and still start the engine. There must be direct contact.

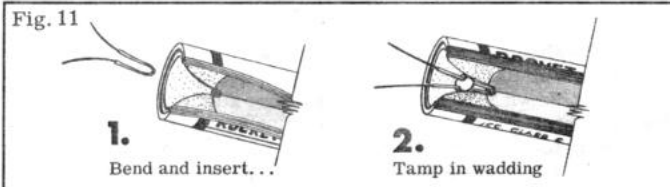

The second point to remember is that the igniter must not "short" or touch itself. The one lead should follow one side of the nozzle; the other lead should follow the opposite side of the nozzle. If these leads cross and short circuit, the current cannot reach the part of the igniter which is against the propellant and the engine will not ignite.

Finally, the wadding must be tamped in carefully and firmly. A small square (3/4" x 3/4") of flameproof wadding (Cat. #RP-1A) is rolled into a ball, dropped into the nozzle between the leads, and forced down further into the nozzle with a ball point pen or pencil point. When the wadding is installed correctly it is possible to pick up the engine by one igniter lead and shake lightly without the igniter coming loose.

It's best to test your igniter installation techniques by flying single engine rockets many times. When you know that you can install igniters and get successful single engine ignition every time, you're ready for a cluster.

CONNECTING THE IGNITERS

For positive ignition all igniters must be connected in parallel. There is a reason for this. If the igniters are connected in series, one igniter will burn through first and stop the flow of electricity to the others. When the igniters are connected in parallel the burn-through of one igniter lets more electricity flow to the others, making them heat faster. A series connection often results in the ignition of only one engine; a good parallel connection almost always results in the ignition of all engines.

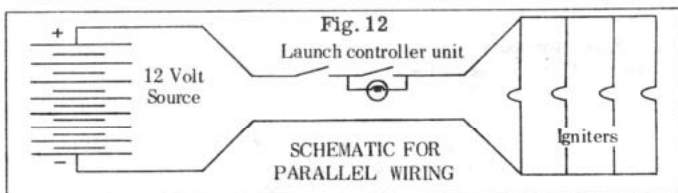

There are several good ways to connect the launcher leads to the igniter leads. In a parallel cluster the simplest method is to use two straight pieces of stiff wire (a straightened paper clip will do) for buss bars as shown. A pair of tweezers can be used to wrap the igniter leads around the wires--one lead from each engine to one wire, the other lead to the other wire. One micro-clip from the launcher is connected to each buss bar.

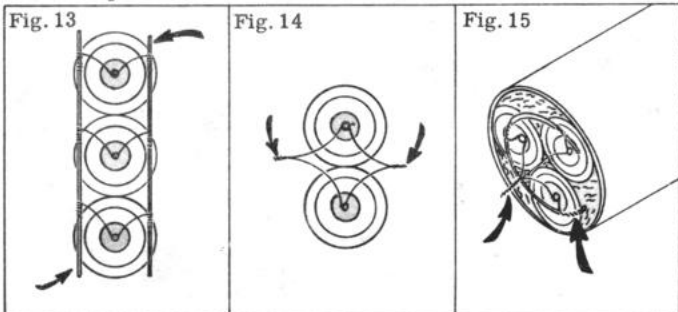

A combination of these two methods can be used for three engine circular clusters. First the engines are placed in the rocket so one igniter lead is toward the inside, the other toward the outside. The inner leads are twisted together. A wire loop (a large paper clip makes good raw material) is then formed and

the outer igniter leads are twisted tightly around the wire of the loop. One micro-clip is attached to the twisted leads at the center, the other clip is attached to the loop.

When two engines mounted close together are used the best method is to simply connect the igniters to each other. If the engines are inserted in the rocket so the leads match as in fig. 14, the ends of the igniter leads can be twisted together quite easily. The launcher's micro-clips are then clipped onto the twisted leads for launching. When twisting or wrapping igniter leads, be careful not to pull the igniters out of the engines or away from the propellant.

Still another method is to use several clips on each launcher lead. The most common way of doing this is to make two "clip-whips" as shown in fig. 16. These clips attach to the igniters, one clip from one whip to one lead of an igniter, a clip from the other whip to the other lead of the igniter. With the clips in place, pieces of masking tape are applied at all points where there is a chance of the clips touching each other. The leads from the electrical launching system are then connected to the twisted ends of the whips.

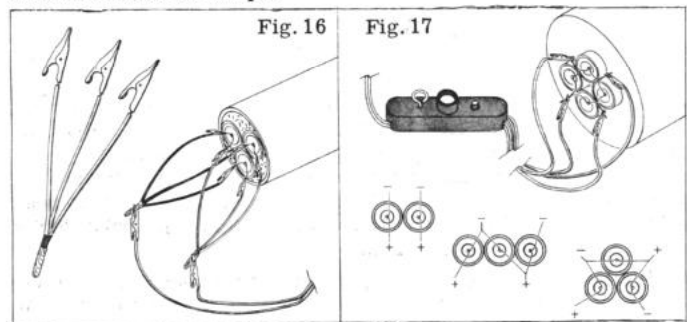

A variation of the clip whip system uses four micro-clips, permanently attached so two fork off from each launcher lead. The leads should be marked so the pairs of clips which are connected to the same lead can be easily identified. This system was developed for use with the four engine cluster in the Uprated Saturn I model, but also works well with two and three engine models. Fig. 17 illustrates a good four-clip electrical system along with several suggested connection methods.

Many other methods can be used to connect igniters on cluster models. The important points to remember are that the igniters must be in parallel, they should be connected as close in to the nozzle as practical and the micro-clips must have clean contact surfaces. Sand or file the jaws of the clips before each launching. After the rocket is on the pad and hooked up make a careful inspection to be sure there are no places where bare leads or micro-clips touch each other and create a short circuit.

THE POWER SYSTEM

Most rocketeers have access to a good, proven power supply for cluster launching--the battery in the family car. A car battery has more than enough power for igniting a reasonable number of engines and need not be removed from the car to be used. A fully charged six volt car battery which has clean terminals can be used to ignite up to 3 engines. However, a 12 volt car battery is far better, and will handle up to four engines easily.

To connect the battery to the rocket and control the electrical current, a heavy duty launch system should be used. The Estes "Launch Control System" (Cat. No. 651-FS-5) or a similar unit is ideal. A suitable unit uses about 18 feet of #18 two conductor wire. Make all connections in the system carefully. If possible solder all permanent joints; a soldered joint conducts electricity better and is less apt to come apart at the wrong time.

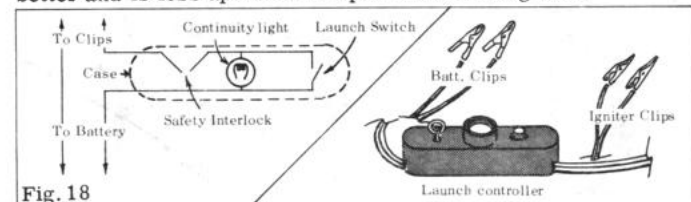

The illustration shows a typical launcher circuit. If heavier wire (#16, for example) is used, the distance from battery to rocket may be increased. If the length of the wires is kept to a reasonable minimum, however, more current will reach the rocket, giving faster and more reliable ignition. Any system must be capable of delivering at least 5 amperes to each igniter.

If the current is less than this the engines will not ignite at the same time; some may fail to ignite at all.

LAUNCHERS

In addition to a heavy duty power supply, a cluster rocket needs a heavy duty launcher. A unit such as the Tilt-A-Pad is designed to handle a cluster model of reasonable size. Even so, special care should be taken. First, the legs should be spread as wide as possible, locked tightly in position, and held down with rocks or bricks. A two-piece rod should be fitted tightly. If the joint between the rod sections is even slightly loose, it can be tightened by soldering (see fig. 19).

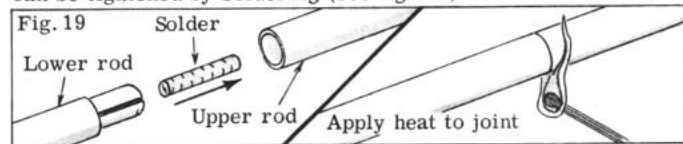

The launch rod for a cluster rocket should be at least 36" long. However, unless something is drastically wrong with the model, there is little reason to use a rod more than 54" long. Normally a 1/8" diameter rod is adequate. For extra large models it may be desirable to obtain a four to six foot long rod of either 3/16" or 1/4" diameter from a local hardware store or machine shop. (If a larger diameter rod is used, a special launch lug will be necessary. A large soda straw will work.)

When a launcher is designed especially for use with cluster rockets it should have an extra large blast deflector and a large, heavy base. A two foot square piece of 3/4" thick plywood makes a good base. The round (Cat. No. 651-BD-2) blast deflector works well with most rockets. A good deflector can also be made from a coffee can as shown.

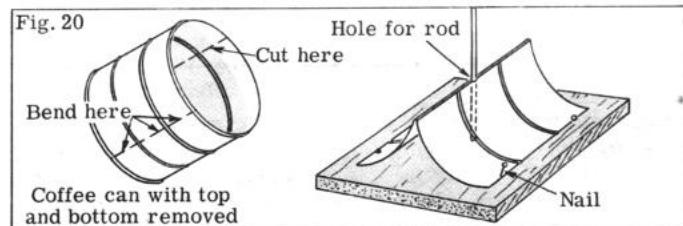

USE A CHECKLIST

To avoid skipping a vital step when preparing a cluster model for flight it is often worthwhile to make up a countdown checklist for your rocket. The list below covers the general requirements of most cluster rockets. For rockets with special characteristics a more detailed checklist should be prepared.

- 18 Install enough loosely packed flameproof wadding to fill the body for a distance equal to at least twice its diameter. Pack the 'chutes, shroud lines and shock cord in over the wadding and slide the payload section into place.
- 17 Select engines of the correct size and pack flameproof wadding into them ahead of their ejection end caps.
- 16 Install igniters in the engines, making sure they touch the propellant grain and do not short circuit.
- 15 Insert the engines into the engine mounting tubes so the igniter leads are positioned correctly. Make sure the engines are held securely in place.
- 14 Connect the igniters together, to a loop, clip whips or buss bar as necessary to form a parallel connection.
- 13 Remove the safety key from the electrical system.
- 12 Place the rocket on the launcher. Support it off the blast deflector if necessary for access to the igniter wiring.
- 11 Clean the micro-clips with a file or sandpaper.
- 10 Connect the micro-clips to the igniters.
- 9 Double-check all connections to make sure the igniters are hooked-up in parallel and there are no short circuits.
- 8 Clear the launch area. Alert the recovery crew and trackers.
- 7 Check for low flying aircraft in the vicinity and for unauthorized persons in the recovery area.
- 6 Arm the launch panel and begin the final countdown.
- 5 4 3 2 1 LAUNCH!