

M O D E L

## ROCKET

ESTES INDUSTRIES • SPRING 1994

NEWS

VOL 34 • #1 • Issue 91

## 1994 NEW PRODUCTS!

Welcome to another edition of the MODEL ROCKET NEWS. First, we and our retailers would like to thank you for your support and business this past year. In this exciting issue we will show off some of our new products for 1994 (in the Leading Edge); we have two articles on how to modify the AstroCam® for "look-down" pictures. "The Rocket Plan" is a design from the past – the Stratos. This plan was originally printed in the May 1973 MRN. Enjoy!

LEADING  
EDGE

## 1994 PRODUCTS

BY MIKE HELLMUND

We at Estes are pleased to announce our exciting new products for 1994. These cover the gamut from E2X level to Estes R/C. Last year we introduced many new and innovative products. This year while still remaining innovative, we are filling some niches that existed in our line. With the mid-1993 year introduction of the E15, this year we feature many products utilizing this more powerful engine.

*continued on page 2*SKILL LEVEL  
REALIGNMENTS

BY MIKE HELLMUND

In the winter 1992 issue of the Model Rocket News we mentioned the realignment of our skill levels. In this issue we would like to mention some of the modifications to those skill levels for 1994.

In the future you will not find a skill level (or the term "Skill Level 0") in the E2X® series of rockets. The rockets in this

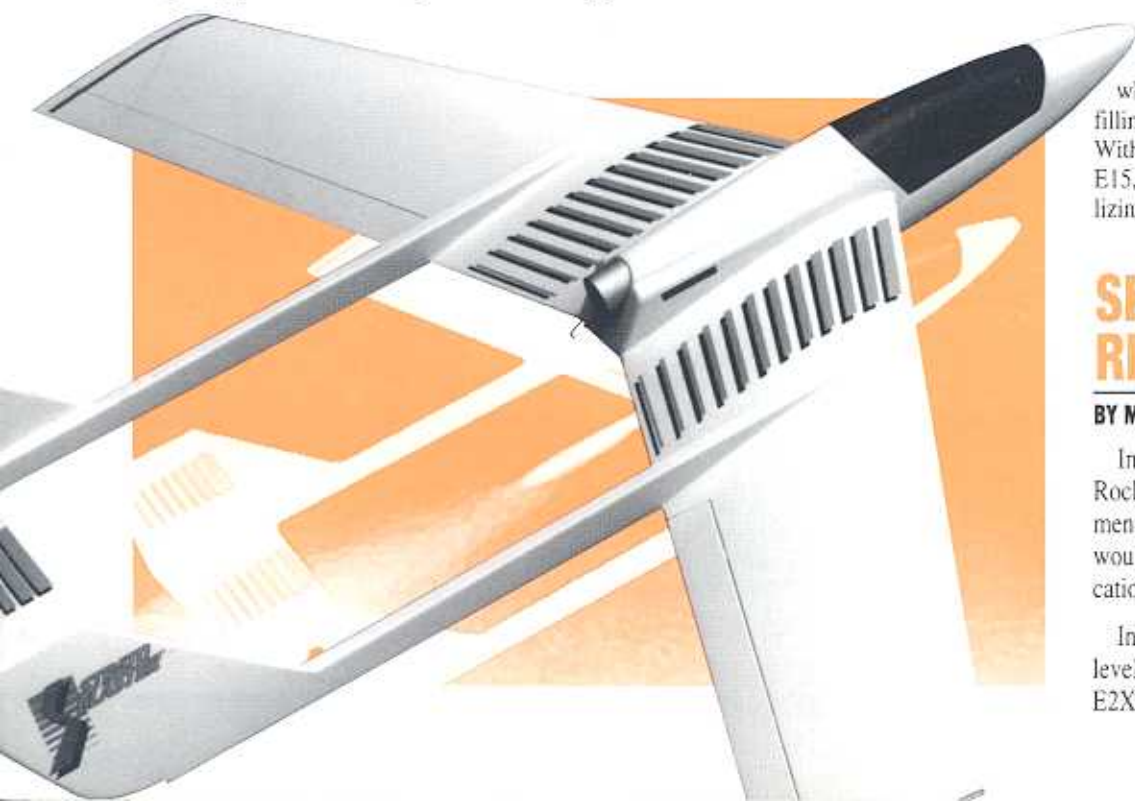
*continued on page 5*

## THE 1994 LINE

There are two new products in our exclusive E2X series. As with the other rockets found in the E2X series, these two new models are easy to build. They require no painting and can have you out on the launch pad in the minimum of time. The first new 1994 product in this series is the **TURBO COPTER™**. This is a regular engine powered, BT-20 size rocket. Its highlight feature is a helicopter recovered nose cone. The main body is recovered by a streamer. The Turbo Copter features a one piece fin unit sporting high performance elliptical fins, pre-colored parts plus neat graphic, self adhesive decals. The Turbo Copter (EST 2096) will carry a suggested retail price of \$8.99. The second new E2X rocket is the **MANTA**. This is our first E2X rocket to feature glider recovery. A futuristic, F-117 like glider rides piggyback on a booster. At apogee the glider disengages, circling back to a gentle landing while the booster section is recovered by a streamer. This rocket is incredibly easy to build with its one piece fin unit and pre-colored parts. The foam glider assembles easily- just glue on the hold down dowel and add a sliver of nose weight. This means the glider is practically flyable out of the box. The Manta (EST 2097) uses regular size engines and has a suggested retail price of \$9.99.

There are two newcomers for 1994 in the Beta™ Series - the two stage **MONGOOSE™** and the **BETA-TRON™ ROCKET BUILDER'S SET**. The philosophy behind the Mongoose is simple- design a two staged rocket that's easy to build and introduces the concept of staging at an early level. The modeler who enjoys the flying more than the building will love this one! The best approach was to design a two stage E2X rocket, i.e., a rocket that was incredibly easy and quick to build and simple to fly. The Mongoose features two pre-colored (purple) one-piece fin units, pre-colored

(yellow) body tubes, pre-colored (purple) nose cones and a set of hot-looking self stick decals. The Mongoose is streamer recovered and can fly almost 500 meters (over 1600 feet) on the C6-0/C6-7 combination. The Mongoose (EST 2092) has a suggested retail price of \$8.99. It's a lot of rocket with a lot of capability at a very reasonable price. We'll talk about the Beta-Tron a little later in this article.

In the Challenge™ Series we have several new rockets. The first is the **MANIAC™** (EST 2091). This is the rocket flier's dream- quick building, no painting, E powered and low cost. This rocket will build under an hour, comes with a



blue nose cone and a heavy duty one piece blue fin unit, and a bright yellow body tube. The Maniac loves E15 engines (over 600 meters- 2000 feet altitude) but also will fly on D12's. With the optional EST 3154 quick change engine mount, you also can fly the Maniac on C's. The Maniac comes with a wild set of self adhesive decals and has a special introductory suggested retail price of \$9.99. The Maniac is the lowest priced E engine rocket on the market. Continuing on in the Challenge series we have two rockets that require more of the type of construction found in this level of rocketry. Both are designed to accept E15 engines (and will still fly on D12's). The first is the **BROADSWORD™**. The Broadsword

is big and sturdy - almost one meter tall (slightly over 3 feet) and 66 mm (2.6") in diameter. The Broadsword (EST 2093) has a heavy-duty engine mount construction. The kit's large multicolored self adhesive logo decal makes this rocket a real eye opener. The Broadsword has a very affordable suggested retail price of \$19.99. The second rocket is the **SHADOW™** (EST 2094) - over 120 cm tall and 66 mm in diameter (47.5" tall, 2.6" in diameter). This is one massive rocket and naturally features a heavy-duty engine mount and a large multicolored self adhesive logo decal. The suggested retail price is \$26.99. Both the Broadsword and the Shadow will get almost 40 percent greater altitudes by using the Estes E engine as opposed to the Estes D.

The **PHOENIX™**, which is also in the Challenge Series (moved up from the Explorer Series- see article elsewhere in this MRN) has been modified to accept the new Estes E15 engine. Since the Phoenix is a scale model there are no external changes. Available under the same part number (EST 1380), the PHOENIX has a suggested retail price of \$21.49.

In the newly recreated Master Series (see related article), we have placed our venerable **SATURN V™**.

The SATURN V has been modified to accept the E15. Since 1994 is the 25th anniversary of the first lunar landing (by humans), Estes has put together a special commemorative edition. The commemorative SATURN V will feature a special 25th anniversary poster and decal included free in specially marked SATURN V kits. These kits also will have a special money back coupon. The SATURN V will retail for \$52.99 and carries the same part number as before - EST 2001.

Although Estes will not have a Collector's Series kit this year, we will be introducing three "old" kits as part of our Commemorative Series. The three kits are all from the "Star Wars" movies. The first kit is the **T-65 X-wing Fighter™**. This is a scale reproduction of the fighter that Luke

Skywalker piloted in "Star Wars" saga. The X-wing features a blow-molded plastic fuselage, many highly detailed plastic parts, die-cut balsa wings and authentic three color decals. The X-wing flies great - almost 100 meters (300 feet) altitude and looks great when on display. Suggested retail price for the skill level three X-wing (EST 2103) is \$16.99. Of course to fly the X-wing, you must have a good R2-D2™ 'droid as a copilot. Estes is reintroducing the flying version of the famous R2-D2. Our model of "Artoo" is 1/5 scale (stands almost 23 cm tall). It incorporates a molded plastic body dome and body skirt, molded plastic legs, a precisely detailed 4 color body wrap-around and is a skill level 2 kit. The R2-D2 has clear plastic stabilizer fins to help with atmospheric flight. The suggested retail price of the R2-D2 (EST 2104) is \$24.99. To go with the good guys, you got to have some bad guys. Rounding out our "Star Wars" trio is the Imperial Forces TIE Fighter™. Our model of the Empire's primary attack craft features a highly detailed plastic cockpit and fuselage and vacuum-formed plastic energy panels. The TIE Fighter, (skill level 3) never intended for atmospheric flight, requires the addition of a special stabilizing recovery probe before each flight. This probe is quickly detached for display. The TIE Fighter (EST 2102) has a suggested retail price of \$21.99.

Although the STRATO BLASTER™ has been out now for a few months, it is still a new product for 1994. All our R/C rocket gliders are placed in their own series- Estes R/C. Please see related article on this new series. The Strato Blaster joins the Astro-Blaster™ as our next generation of rocket powered R/C gliders. The Strato Blaster features a blow molded fuselage, quality foam wings and die-cut balsa parts. Configured to fly on E15-P engines (the Astro Blaster has also been reconfigured), the Strato Blaster can also be flown on D11-Ps. With the E15-P, you can expect about 600 feet altitude. The Strato Blaster has thermalled more than eleven minutes here at the Estes plant. As with the Astro Blaster, the Strato Blaster performs equally well as a slope glider or can be field-converted to fly with an .049 glow engine. This newest creation from Estes is an aileron/elevator controlled aircraft, requiring 2 channel mini or micro gear. The Strato Blaster has simple assembly and finishing, requiring about 12-18 hours of

construction time. While it is not a beginner's aircraft, the Strato Blaster can be easily flown by modelers with aileron-equipped glider or sport aircraft experience. The Strato Blaster (EST 2090) carries a suggested retail price of \$69.99.

In 1994, Estes is pleased to introduce two new accessories. The first is a tool that both the experienced and beginning modeler will find useful. The ROCKET BUILDER'S MARKING

GUIDE is a series of tools, constructed of sturdy yellow plastic, that allow the modeler to mark body tubes both accurately and effectively. The first tool has a series of disks, stacked on top of each other like a layered cake, that allow the modeler to slip on the appropriately sized body tube and mark fin positions for a three finned or a four finned rocket. In the Marking Guide there are two sets of these "stacked disks" - one stack fits BT-5, BT-50, BT-60 tubes. The second stack fits BT-20, BT-55 and BT-80 tubes. The other tool in the Marking Guide is an adaptation of the "piece of angle" that you could buy at a hardware store. The plastic angle with the Estes Marking Guide has multiple functions. It has a pencil holder at one end that will allow you mark the circumference around any size tube and a handy jig for fins between 1/16th and 1/8th inch thick at the other end (the jig keeps the fin straight as it's being glued). The Marking Guide has a metric and SAE (inches) ruler. There are slots (along with the outside edges of the angle) that will allow you to draw straight lines (such as for fins or launch lugs) onto tubes. The Marking Guide (EST 2227) has an amazing suggested retail of \$4.99.

The second new accessory is a DECAL ASSORTMENT. Estes will be offering six different types of decals packaged two to a bag. One assortment (EST 2997) features water transferable wrap-arounds for BT-20, BT-50 and BT-60 sized rockets. The second set of decals (EST 2995) is also water transferable and has letters, U.S. flags

and the military "stars and bars". The third set (EST 2996) is a self adhesive decal set, printed on chrome colored paper. That set has a variety of wrap-arounds, hatches etc. Each one of these decal sets has a suggested retail price of \$1.99.

The last new product for 1994 that we would like to introduce at this time is the BETA-TRON™ MODEL ROCKET BUILDING SET (EST 1464). As we mentioned earlier this a Beta level kit. This set's main purpose is to introduce the consumer, who is already familiar with E2X rockets (and possesses their own launch equipment) to the wide, wonderful, world of rocket modeling. The Beta-Tron set will allow you to acquire the skills and knowledge needed to become a successful rocket modeler. Everything is easily explained in the new, updated, full color Estes Tech Manual and a set of easy to follow general instructions. With the Beta-Tron you can build two different BT-50 models. You design them, you build them, the manual and instructions will help you. The set comes with nose cones, body tubes, die-cut fins, a payload section, recovery systems (both parachutes and streamers), two sheets of decals (the same found in our decal assortment), and a paper altitude tracking device. To make the building and marking of your rockets easier, we have included the new hi-tech Rocket Builder's Marking Guide tool set. Then when you're done building your designs, there are three engines (A8-3, B6-4 and C6-5) to fly your designs. The Beta-Tron is the perfect stepping stone into the Beta Series of rockets and will carry a suggested retail price of \$24.99 (for over 42 dollars worth of stuff!).

These are the new products that we are introducing for 1994. The one thing above everything else, that we are proud of is the high quality that goes into all Estes rocket kits and accessories. We are constantly testing our products- improving, tweaking, updating as we go. As always, we reserve the right to introduce more new product as next year progresses. So enjoy our current items and stay tuned for further developments.

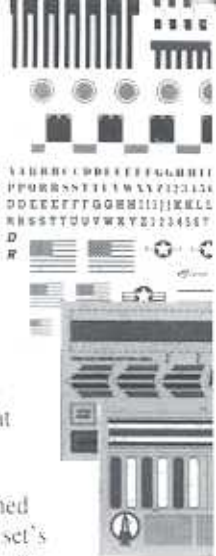
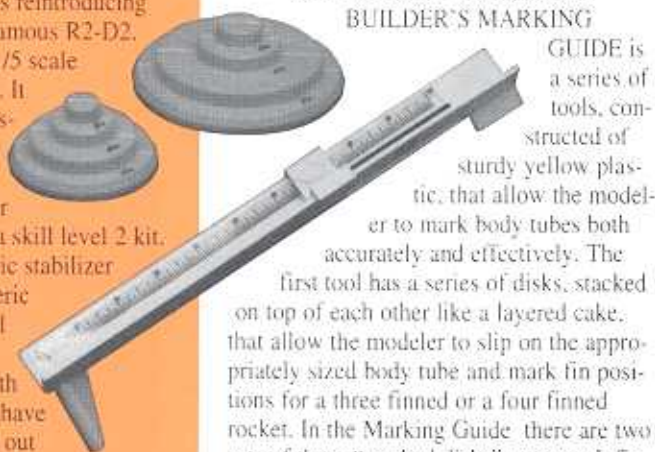



Robert A Zingarelli  
Bay St Louis, MS 39520

To keep dust off of sensitive payload parts, such as the lens and mirror of an AstroCam, slip a ziplock or reclosable kitchen storage bag over the nose and payload section, zip or reseal the opening tight against the body tube when the rocket isn't being launched.



Jeffrey Thomas  
North Branford, CT. 06471

A "Fanny Pack" is quite useful for carrying masking tape, sand paper (and/or an emery board), extra engines, a clothes pin or a spent engine (to use as a rocket stand-off), igniters and igniter plugs. You can eliminate needless trips to your range box, by having your important supplies with you.



Mort Binstock  
Pittsburgh, PA. 15218-1144

A badly crinkled body tube can be strengthened quickly using instant glue. Instant glue will restore the body tube's strength and rigidity. First, as best you can without incurring further damage, straighten out the body tube. Then apply a thin viscosity (fast setting) instant glue (Cyanoacrylate or CA) to the crinkle. Allow it to soak in for a minute then zap with a very fine mist

of instant setter— not too much or the CA will foam. Lightly sand the repair area, repeat if necessary.



Lloyd Balch  
Brooklyn, NY. 11230

To keep your micro-clips clean and longer lasting, wrap aluminum foil over the clips. You can also attach the clips to paper clips and then clip the igniter leads in between the paper clips.

# RUMBLING

## from the pad

### IMPROVEMENTS

You will notice that starting in 1994, all of our parachute kits (12" EST 2264, 18" EST 2267 and 24" EST 2271) will come with snap swivels. This will help keep the parachute shroud lines from tangling, once the chute is deployed. It also makes it easier to change out the parachutes. We have also changed the colors and improved the instructions for our parachutes. The 12" parachutes will be orange and blue, the 18" will be purple and blue, while the 24" parachute will be red and blue.

The Emergency Repair Kit (EST 2233) is back after a short absence. It has a new resealable bag and now includes micro-clips. The suggested retail price for the new repair kit is \$6.79. Also back and repackaged is the Safety Cap and Key (EST 2205)

Watch for more revisions in our accessories and parts in the near future.

### REVISED AND UPDATED

We have rewritten and revised a few of our publications. The most dramatic is the Technical Manual (EST 2819). This has been revised with the help of two expert rocket modelers - Dr. Thomas Beach and Dr. Joyce Guzik. Not only is the Tech Manual updated but it has also been printed full color. This valuable booklet is available for 80 cents.

Two of our technical reports have been revised. The first is TR-1 and it covers stability and the second is TR-3, covering Altitude Tracking.

By the time you are reading this MRN the 1994 Estes catalog should be out.

### ATTENTION SCALE MODELERS

There is a new book out that is perhaps the world's most comprehensive reference for rockets. Peter Alway's *Rockets of the World - A Modeler's Guide* is available as

## The 1994 Estes Catalog Is Here!

Pick one up at your local hobby store or call or write Estes Industries today for this complete information filled products catalog!

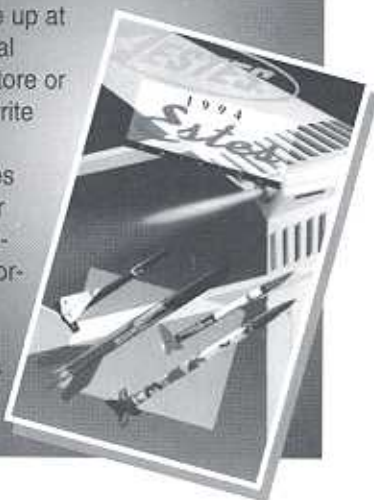

a hardback or as a softback. This book gives you 380 pages of scale data (over 200 versions of 133 different rockets) complete with dimensions and color keyed drawings. There are also over 170 photographs. The book comes complete with historical summaries for each of the 133 rockets. If you love building scale rockets, then this book is an absolute must for your library. For more information contact Peter Alway, Dept E.L., P.O. Box 3709, Ann Arbor, MI 48106-3709.

### HIT LIST

The following kits have been officially discontinued by Estes. If any of your favorites are on this list, then rush on down to your local hobby store and pick them up while you still can. Iris (EST 2007), Warp II (EST 2022), Photon Probe (EST 2043), Solar Sailer (EST 2044), Blackhawk (EST 2053) Lumina (EST 0897) and Beta Launch Vehicle (EST 2054).

# SKILL LEVEL REALIGNMENTS

(continued from page 1)

skill level are almost ready to fly and you will find that statement printed on the packaging and the catalog.

The next change, as mentioned in the Spring 1993 issue of the MRN, is that Pro Series is not a skill level but rather a product line. In the Pro Series you will find a skill level range from easy to difficult. The Pro Series rockets will be of heavy duty construction and are intended for modelers over the age of 16. The engines in Pro Series will be at least as powerful as a D.

The definition of Master Series has changed. Master Series will be skill level 4. Finely honed modeling skills are a must and the construction is very complex. The engines in Master Series can be single, cluster, and/or multi-stage, with engines no more powerful than an E. The Master Series' emphasis will be on building rather than flying.

The Estes R/C Series is also new for 1994. As with the Pro Series, this is a product line, not a skill level. In this product line you will find all of our R/C products.

What kit goes where? Here is a list of products that have changed skill levels:

Prod #	Kit Name	Old Skill Level	New Skill level
1960	Nova Payloader	Explorer	Beta
1380	Phoenix	Explorer	Challenge
1382	Comanche 3	Explorer	Challenge
1942	SR-71 Blackbird	Explorer	Challenge
1274	Klingon Cruiser	Challenge	Master
1275	USS Enterprise	Challenge	Master
1284	Space Shuttle	Challenge	Master
2016	Explore Aquarius	Challenge	Master
2001	Saturn V	Challenge	Master
2073	Astro Blaster	Challenge	Estes R/C
2090	Strato Blaster	—	Estes R/C

Estes R/C is intended for modelers who possess basic R/C experience in both usage and building. Many of the skills needed are the same used in the R/C airplane arena. You will need to provide your own R/C equipment (transmitter, receiver, servos, batteries etc).

This will probably be the last tweaking we need to do to the skill levels and product lines. You may still find some rockets that have packaging that reflects old skill levels. Bear with us as packaging gets changed.

# STAR WARS®

You can own these replicas from a long time ago in a galaxy far, far away!

Estes is pleased to reintroduce these Commemorative Series models from the exciting Star Wars saga. There are three

highly detailed kits in this series: the Rebel X-wing Fighter, a flying R2-D2 and the Imperial TIE Fighter. Collect all three of these fantastic kits and may the Force be with you!



15<sup>th</sup>  
ANNIVERSARY  
COMMEMORATIVE  
SERIES

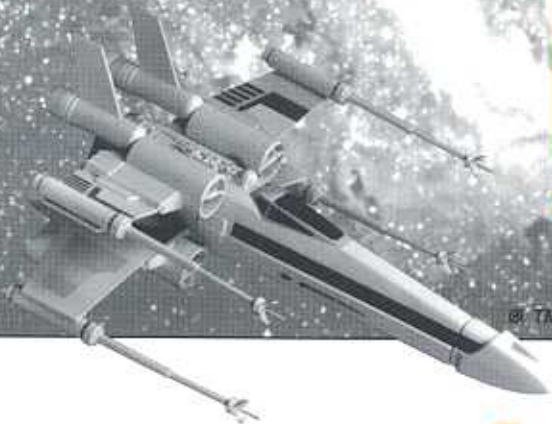

X-WING FIGHTER™  
EST 2103  
\$16.99



R2-D2™  
EST 2104  
\$24.99



TIE FIGHTER™  
EST 2102  
\$21.99

©, TM & © 1993 Lucasfilm Ltd. All Rights Reserved. Used Under Authorization

## DESIGN OF THE QUARTER WINNERS



As always we have many exciting Design of the Quarter entries. Remember we are looking for uniqueness, innovation and proven performance. The new Rocket Builder's Marking Guide (EST 2227) is a great help with building your new designs. And if you are just starting up the rocket design trail the new Beta-Tron Rocket Builder's Set (EST 1464) will teach you a lot about designing and building rockets. For those experienced modelers out there try the Designer's Special (EST 1463).

The winner of the first quarter, 1993 Design Contest is **Dale Rolfe** of Madison AL, with his easy to build, yet unique looking fish...ah... rocket, called "JAWS". The close runner up was **Mike Rotenberg's** bi-winged design called "MAD MAX". Mike hails from Yellville, AR.

Winner in the second quarter contest was **Ryan Hollister** and his friend **Eric Jeffery** with their unique fin design rocket, the "MID-NIGHT RAIDER". These two guys call Turlock, CA, home. Honorable mentions go to Quakertown, PA's **William Sullivan** and his futuristic looking "BANDERSNATCH" and to **Joe Landherr** of Rose Creek, MN and his three D staged "TRIPLE PLAY"

The third quarter's winner was **Carl Reese** (of Clinton, IA) and his semi-scale "F-14 TOMCAT" (parachute recovered). Carl's instructions were very well done! We had two honorable mentions: **Eric Laschinger** of San Jose, CA, and his little "254" rocket; and **Rocky Eckhardt** of Seneca, MO and his "SCHEME IN DEMON" with on board ignition system.

Congratulations to all award recipients. The winners receive a \$100 merchandise certificate and honorable mentions receive a \$25 merchandise certificate.



In this issue we will not be having a "QuickTech" article. Instead we have chosen two articles on how to make the picture-taking AstroCam, one of the most unique rockets you can buy, build and fly...even better. Have fun!

The first article is by Art Nestor, one of our long-time MRN contributors and perhaps the world's expert on AstroCam utilization. The other article is by Mike "Bill" Dennett. Bill is an expert rocket modeler and someone who likes to cram the largest possible engine in a given rocket. The AstroCam hasn't escaped his clutches!

## BETA-TRON™ ROCKET BUILDER'S SET *Ignite the Imagination*



EST 1464

- Everything easily explained in the new, updated, full color Estes Tech Manual and the easy to follow Beta-Tron instructions.
- The new amazing hi-tech Rocket Builder's Marking Guide™. This tool set makes the marking of body tubes a cinch. No more door jams, no more crooked or misaligned fins!
- Enough materials to build one or two original rockets- rockets of your own design. Includes body tubes, nose cones, a clear payload section, parachutes, streamers, die cut fins, two full sheets of decals and much more!
- Plus three engines (including igniters, plugs and wadding) and paper altitude tracker to see just how high. All you need is your Estes launch equipment.



## THE LOOKDOWN ASTROCAM

BY ART NESTOR • NAR #29623 • ZELIENOPLE, PA

One of the most rewarding activities of model rocketry is aerial photography. Good aerial photos are an immense source of pride to a rocketeer. They give the viewer the feeling of actually being on board the rocket. And critics who believe your hobby is of little value are quickly silenced when shown spectacular pictures taken from the unusual vantage point of the rocket itself. Estes Industries has long been known for its relatively inexpensive, mass produced model rocket cameras. The tradition began in 1965 with the Camroc and continued with the Cineroc in 1970, the Astrocam® in 1979 and the newly redesigned Astrocam® in 1993. For me, aerial photography is a major source of fun and satisfaction.

Today, I fly the Astrocam® almost exclusively using what is called the Lookdown method. That is, the photo is taken looking down at the ground as the rocket is still climbing straight up. This article discusses the pros and cons of three different ways to build and fly a Lookdown Astrocam®, none of which is difficult to understand or construct. However, it is recommended that the rocketeer have some experience with model rockets before attempting it. In all three methods, we are simply turning the

*continued on page 7*

# THE ROCKET PLAN

Plan Number  
**77A**

# STRATOS

## Passenger Shuttle Rocket



This plan appeared in the May 1973 issue of the Model Rocket News (Vol 13, No. 1). The Stratos was designed by Tim Barber of Deer Park, Washington. The plan has been slightly modified to include updated parts and revised hints. Have fun!

PART DESCRIPTION	QUANTITY	PART NUMBER
Engine tube - BT-20J .....	1	30326-1
Body tube - BT-50.....	1	30352
Body tube - BT-5.....	1	30302
Nose cone - BNC-5W.....	2	70218
Nose cone - BNC-50Y.....	1	70266
BFS-30.....	3	32108
Centering rings - AR-2050.....	3	3100
Engine block.....	1	3131
Launch lug.....	1	2321
18" Parachute kit.....	1	2267
Shockcord - SC-1.....	1	2276
Engine holder.....	1	3140
Screw eye.....	1	2279
Shroud line 51 cm (20").....		2340
Masking tape 13 mm (1/2") x 90 mm (3-1/2")		

1. Cut a 3 mm (1/8") slit in the BT-20J, 6 mm (1/4") from one end. Apply a drop of glue to the slit and also straight along the tube for approximately 19 mm (3/4").
2. Push one end of the metal engine hook into the slit. Press the hook into the glue and align straight along the tube. Wipe away any excess glue.
3. Tightly wrap the 90 mm (3-1/2") piece of 13 mm (1/2") wide masking tape around the 25 mm (1") from the end with the slit.
4. Using a sharp hobby knife, cut a 5 mm (3/16") section from one of the AR-2050. Smear glue around the cut ends. This will keep the ends from unravelling.

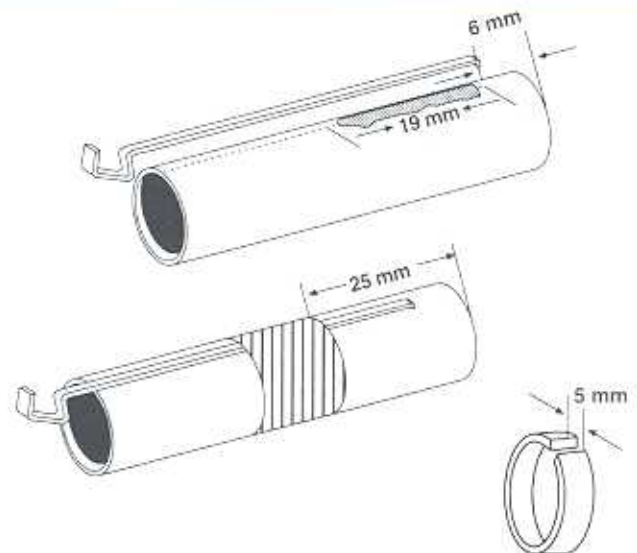

- 5. Glue the EB-20A engine block into the end of the BT-20J so that it touches the EH-2 engine holder. Mark the tube 3 mm (1/8"), 19 mm (3/4"), and 57 mm (2-1/4") from the end as shown.

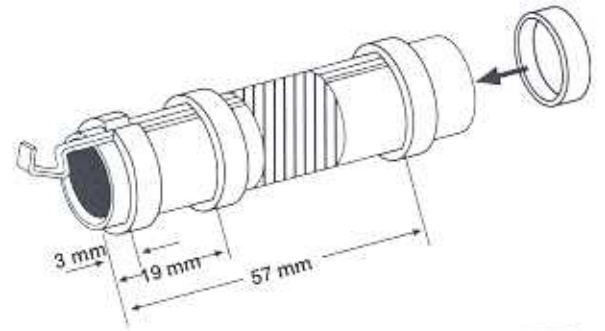

- 6. Glue the two uncut AR-2050's on the forward edges of the 19 mm (3/4") and 57 mm (2-1/4") marks. Glue the cut AR2050 on the forward edge of the 3 mm (1/8") mark.

- 7. Cut two 140 mm (5-1/2") lengths from the BT-5. Glue a BNC-5W nose cone into one end of each of the BT-5's. This would be a good time to sand seal the nose cones.

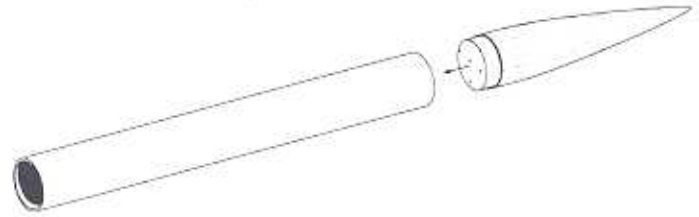

- 8. Cut the BT-50 to 267 mm (10-1/2"). Wrap the tube marking guide around it and mark at the arrows. Connect the tube marks with straight lines.

- 9. Repeat the procedure on the pods, using the BT-5 marking guide. Number all lines.

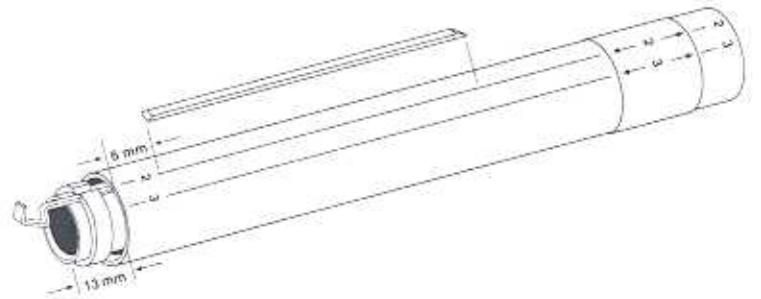

- 10. Trace pod brace pattern #2 onto balsa, cut out, and shape as shown. Slightly bevel the sides. See rear view figure below. Glue brace to BT-50 straight along line #2, 6 mm (1/4") from end of the tube.

- 11. Glue the engine mount assembly into the end of the BT-50. Leave 13 mm (1/2") of the end of the engine mount extending from the end of the BT-50. The EH-2 engine holder must be in line with the brace and line #2. The "cut" AR-2050 ring will remain exposed.

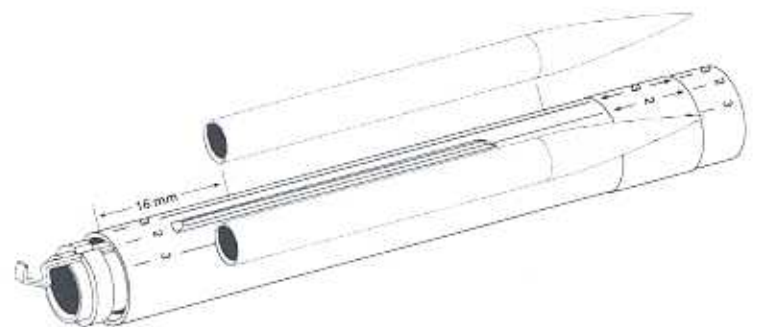

- 12. Glue the pods to the BT-50, one along each side of the brace 16 mm (5/8") from the end of the tube, and with the #2 lines on the pods lined up with the #3 lines on the body. Set aside to dry.

- 13. Trace wings, tail fins, elevators, antennas, radar pod halves, and rudder sections 1 & 2 onto balsa and cut out. Place a piece of wax paper on a flat surface. Glue the two rudder sections and the two elevator sections together. Lay flat on the wax paper to dry.



REAR VIEW



**TIP:**

To make it easier to glue the jet pod, radar pod and antenna in the proper locations, match the template of the wing to the balsa counterpart cutout in step 13. With a pin, gently punch a series of small shallow holes along the dotted lines. This will "transfer" the correct position of the jet pod and antenna to the balsa wing. Follow this same procedure for the radar pod on the rudder. Remember to do this for both wings and both sides of the rudder.

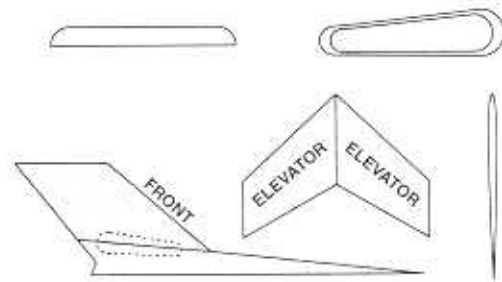

- 14. When dry, sand all fins to shape shown. Sand radar pod to shape shown.

- 15. Glue the launching lug along the center line of pod brace #2 and 19 mm (3/4") from the rear of the brace. Cut out brace #1 and sand to shape. Glue brace #1 between the pods over the launch lug with the rear of the brace even with the rear of the launch lug.

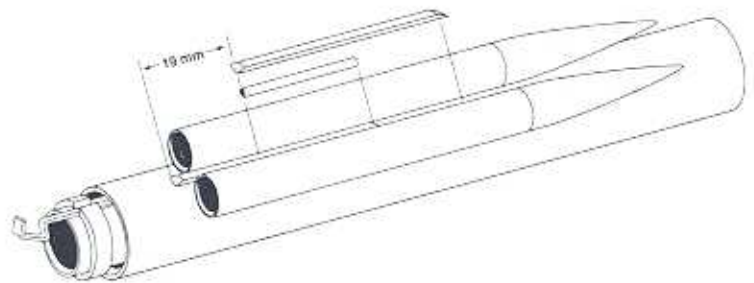

- 16. Glue radar pod halves, the tail fins, and the elevators in the indicated positions. Sand all edges of the antennas flat and glue in place. Let dry completely.

- 17. Cut two 70 mm (2-3/4") lengths of BT-5, glue one to the top of each wing in the position indicated on pattern sheet.

- 18. Apply glue to the root edge of the rudder assembly. Glue it straight along line #1 with the rear edge 16 mm (5/8") forward from the rear of the body tube. Make sure it sticks straight away from the tube. Glue the wings along the #1 lines on the pods with the rear edge 8 mm (5/16") ahead of the rear of the pods.

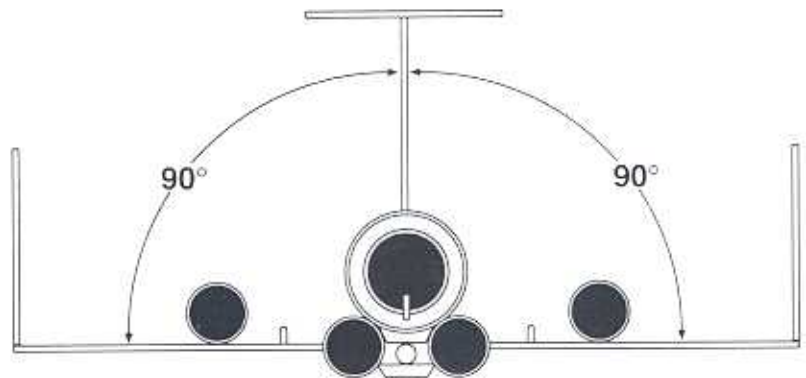

**IMPORTANT:**  
The rudder is glued at a 90° angle from the wings. Let dry

- 19. Twist the screw eye into the base of the nose cone, twist out, squirt a drop of glue into the hole and twist screw eye back in. Assemble the parachute per instructions in the 'chute kit, gather the shroud lines, and tie them to the screw eye. Tie one end of the shock cord to the screw eye. Apply a fillet of glue to all joints and allow to dry until hard and clear.

- 20. The recovery system on this rocket is intended to minimize fin damage on landing. Find the C/G of the model without the nose cone and with an empty engine casing in place. Using a sharp needle make a small hole through the base rudder section at this point and pass the 51 cm (20") shroud line through to the center of the line. Squirt a little glue into the hole. Tie the ends of the line together and tie them securely to the free end of the shock cord.

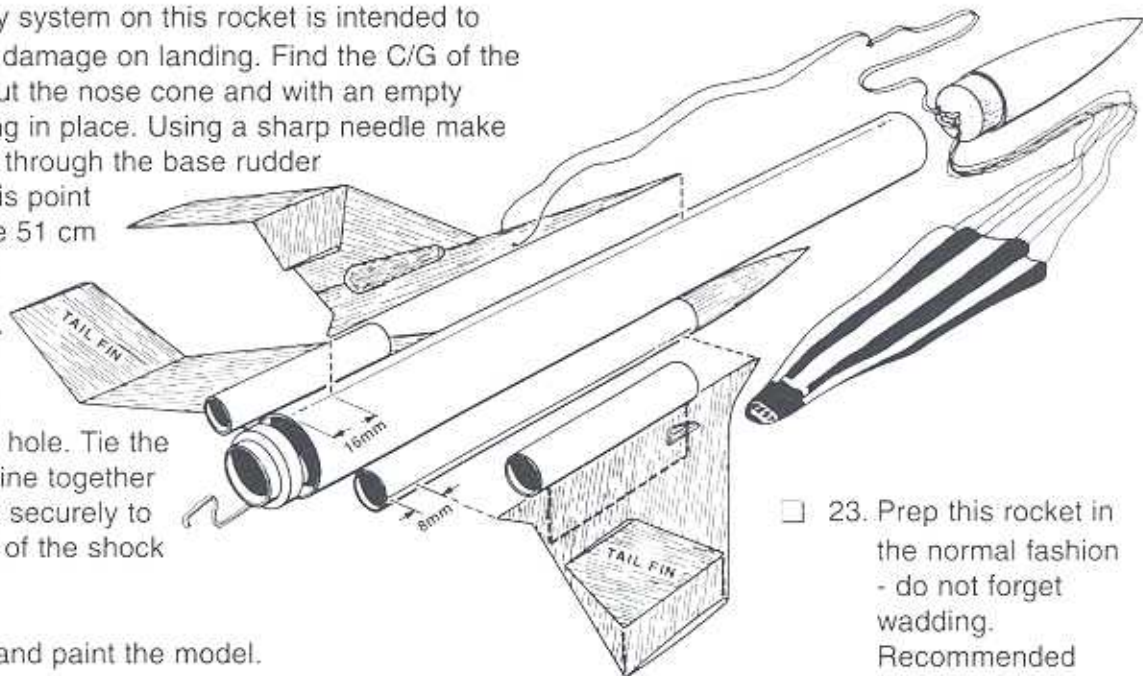

- 23. Prep this rocket in the normal fashion - do not forget wadding. Recommended engines are A8-3, B6-4, B4-4, and C6-5.

- 21. Sand, seal, and paint the model.
- 22. You can decorate your model in several ways. The new Estes decal set (EST 2995, 2886, and 2997) may offer you some choices. The decal set (037465) from the Deep Space Transport (EST 2034) would work well. Another option is to ask your local hobby shop if they stock airline decals.

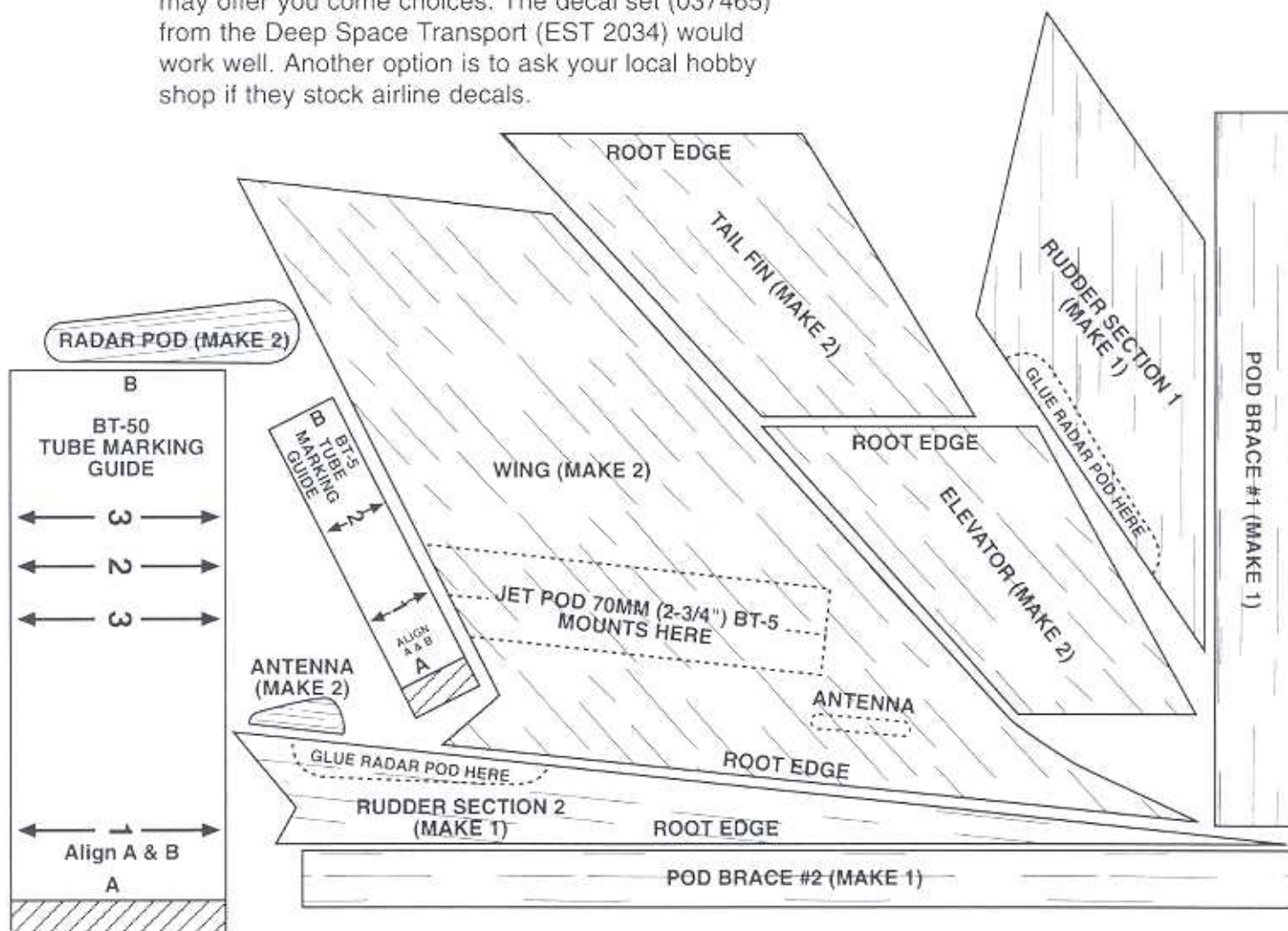

# THE LOOKDOWN ASTROCAM

CONTINUED FROM PAGE 6

camera upside down and then, by making changes in engines and booster rockets, taking the photo from the new camera position. Almost always, poor Astrocam® photos are not the fault of the camera but rather the

another method, be sure to give extra consideration to safety. Do a preflight swing test for stability. At launch, keep spectators a little further away than usual. For best results, all rockets should be equipped with Maxi launch lugs and flown from 3/16" diameter launch rods.

In all three methods discussed here, an unmodified Astrocam® is flown upside down with the addition of adapters as shown in Fig. 1. It is necessary to secure a

## SHORT DELAY METHOD

The Astrocam® is turned upside down as previously illustrated and flown with a short delay engine in a BT-56 diameter booster rocket such as the rocket supplied with the AstroCam® 110. Recommended engines are the B6-2, and the C5-3. The D12-3 and E15-4 engines may be used with an appropriate rocket or modification to the rocket supplied with the AstroCam® 110 (see following article). Advantages to this method are ease of operation, one engine per flight, and a relatively high altitude at ejection. The main disadvantage is that motion of the camera at ejection may cause some fuzziness in your photos. Inexperienced flyers may want to try this Lookdown method first.

**Editors Note:** There is a difference between a BT-56 and a BT-55. The BT-56 is slightly larger in diameter than the BT-55. A BT-55 nose cone will

Fig. 1



forces acting on the camera such as speed and motion. By changing booster rockets and/or engine type we can have more control over the timing of the ejection and select a less turbulent moment in the rocket's flight to snap our picture. So while the camera is essentially the same, it is the changes in how it is flown that will make the most difference. Careful use of the Lookdown Astrocam® will increase the number of good photos from a roll of film. In fact with this method, the biggest problem of good aerial photos will not be blurred photos or sky shots. It will be finding enough launch sites that contain good subject matter to photograph.

Flying the Lookdown Astrocam® with short delays or the multi-stage method requires a different approach to selecting a launch site. Since the photo is taken during climb out, the launch area is nearly always the subject. Place your pad as close to an interesting object (such as a house or car) as safety will allow. To take the Lookdown photo that appeared in the 1989, 1990 and 1991 annual Estes catalogs, I placed my launch pad in between the heavy equipment. Be careful when launching next to cars as the falling booster stage may land on them. The lower end of the rocket always appears in a Lookdown photo, increasing the sensation of really being on board.

There are other ways of flying a Lookdown Astrocam® than the ones I am presenting here. But I believe these are the easiest and best methods. If you do attempt

screw eye into the tip of the camera for attachment of a shock cord. Make a SMALLER starter hole in the tip of the camera with a drill or a hot piece of wire. Screw in the eye and then epoxy it inside and out. The screw eye will not show in the photos.

Give extra attention to the construction of the recovery system. The parachute will be under additional stress if you are using an extremely short delay engine and it ejects at high speed. Attach the parachute to a 4" length of shock cord looped through the screw eye.

## REAR EJECTION BOOSTER (D - ENGINE)

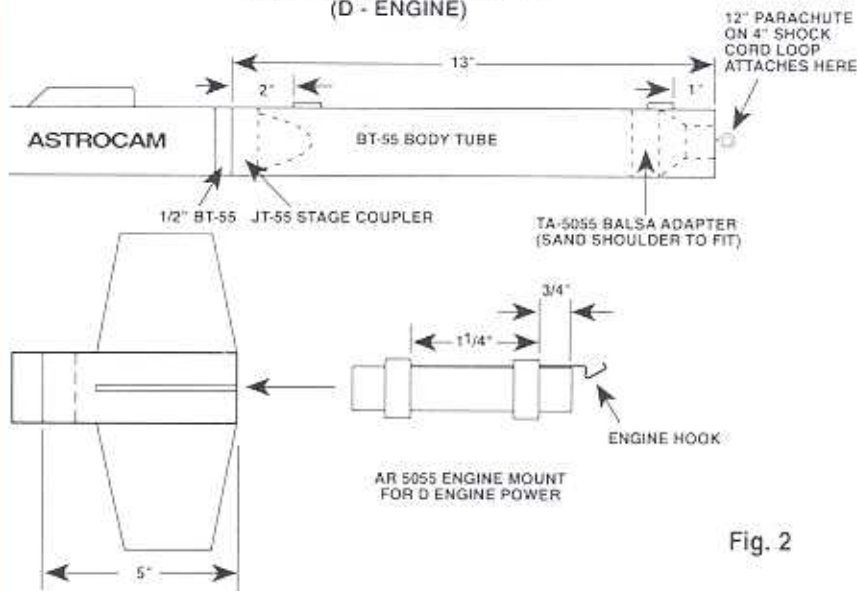

Fig. 2

loosely fit in a BT-56. A BT-56 nose cone may fit snugly into a BT-55, however, you may have to sand the shoulder of BT-56 nose cone to fit. Kits that use a BT-56 body tube and nose cone are the AstroCam, Helicopter, Maniac, Scrambler, and Ormoid. A white 18" long piece of BT-56 has a part number of 30393 and a 12" piece of BT-56 carries a part number of 31606.

## REAR EJECTION BOOSTER METHOD

This is a popular technique which probably produces a better quality picture than method one. It is very similar in concept to

the Short Delay method except that the parachute now ejects from the rear of the rocket. The reasoning is that the "kick" of the ejection is now transferred away from the camera to the bottom of the rocket.

Add the camera adapters as shown in Fig. 1. Now, take a close look at the rear ejection rocket shown in Fig. 2. NOTE that the Astrocams® does not eject. The rocket now separates and ejects the parachute from the lower end. Lengthen the shutter cord to reach this separation. Sand the shoulder of the TA-5055 balsa adapter to slide into BT-55 body tube.

Also note that there is no shock cord connecting the upper and lower sections of the rocket. A shock cord this close to the engine could be damaged frequently from the heat of ejection. Furthermore, by eliminating this connection you get rid of the parachute clutter that can entangle the shutter cord after ejection. If the shutter cord becomes caught in the recovery system, it will ruin your photo by continuously tripping the shutter, causing multiple exposures. The lower part of the rocket uses tumble recovery. The 12" parachute is attached to a 4" long loop of elastic shock cord that runs through the screw eye in the adapter. Be sure it is packed with a good amount of recovery wadding in the lower section of the rocket.

The rear ejection advantages should be more reliable and sharper looking photos. There are no real disadvantages but you will need to build the special booster rocket. Recommended engine is the D12-3 only. It is also possible to stage the rocket for additional altitude. You may build this version using your own design or build one using templates supplied.

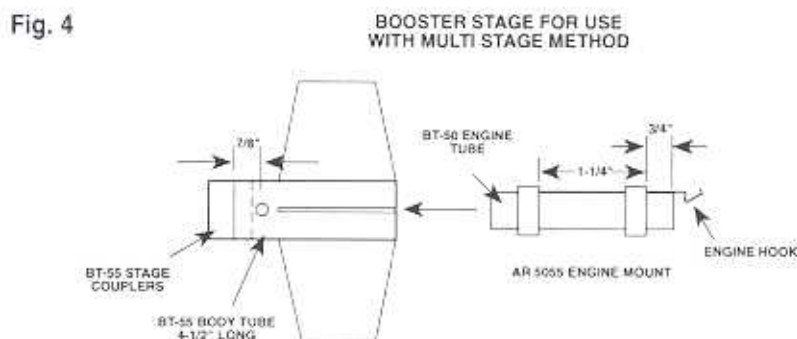
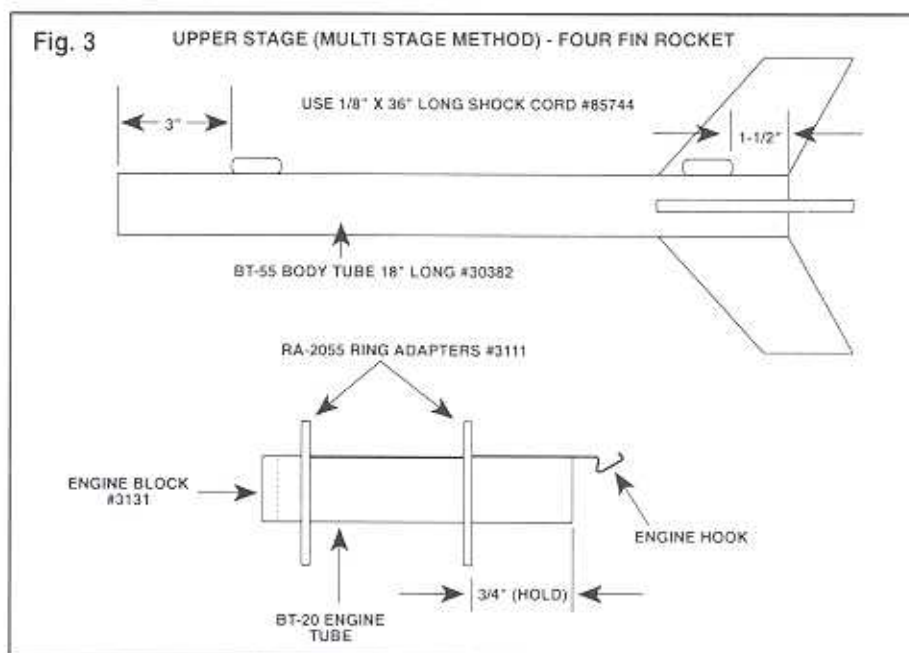

### MULTI STAGE METHOD

This is the technique I used when I took the Lookdown photo for the annual Estes catalogs. Again, add the camera adapters as shown in Fig. 1. The rocket will now be a two stage rocket. (See Fig. 3 and Fig 4.) The shutter cord is lengthened and pinched between the two stages. The photo is taken as the second stage ignites and the first stage drops away. This is the method I prefer. It offers superior picture quality and the usual ability to catch a picture of the rocket in the process of staging. From a roll of 12 exposures, you should get at least two staging photos of exceptional quality.

The purpose of the top stage engine must be considered. A low powered

engine such as an A8-3 will keep the rocket close to the launch site while a higher powered B6-4 might be necessary to help carry the camera away to a safer landing spot. Use a 12" parachute. See Chart 1.

Disadvantages are that two engines are used per flight, the shutter cord may tangle in the recovery system or need occasional repair (but not after every flight) from the wear and tear of the staging process. However, I believe the photo benefits far outweigh the added expense and launch preparation. This method offers the widest range of altitudes with a single booster rocket.

Chart 1

RECOMMENDED ENGINES FOR THE MULTI STAGE METHOD			
1st Stage	B6-0	C6-0 (first flights)*	D12-0
2nd Stage	B6-2	A8-3 or B6-4	A8-5

\* Use an EM2050 (EST 3154) to quick change from D engines to regular engines

# THE LOOKDOWN ASTROCAM®, MKII

BY BILL DENNETT

The construction of this modified Astrocam® is not much more complex than the stock kit, which is a breeze. You'll need a few parts from Estes plus a stock Astrocam kit. The total investment is pretty small, and for it you get an aerial photography package with very interesting possibilities.

I've designed this model to use up to E engines. What?!? Yes, the model flies very well on our new E15's, and reaches tremendous altitudes. Photos can be taken from well over 1000 feet with these engines! You do need a decent sized field, since in a breeze, the model can drift a long way. It also flies well on D's, or B's and C's too - with the B's and C's, you need an adapter.

Let's get started -

## (1) THE CAMERA:

Construct the camera unit exactly per the instructions supplied, except for two important details:

(a) Remove the stock shutter cord by picking the knot out from the hole in the shutter with a sharp pin. (Remember which way the cord is fed through).

Take a 12" piece of Estes shroud line or polyester button thread, and tie two or three knots close to one end. Feed the untied end through the shutter in the direction of the

old cord, and pull the knots snug into the hole. Trim off any excess hanging out from the knotted end.

(b) Drill a small pilot hole in the tip of the camera nose cone, then install the screw eye. Cement securely inside the cone to help avoid pulling out.

## (2) THE ROCKET VEHICLE:

The engine mount assembly is much different when built for D or E engines. NOTE: If you wish to use only C or B engines, then you can build the rocket vehicle exactly as the instructions describe. However, you should still substitute the 1/4" shock cord to endure the stress of deployment while the



rocket is moving. Also, you will need to make or purchase an extra engine mount centering ring, since one is needed to make the camera/body tube adapter.



**IMPORTANT** - save the stock engine mount centering rings.

"Glue" means white or yellow wood glue.

"Cement" means tube type plastic cement.

(1) Draw two straight lines, 1/8" apart, along the 4" engine mount tube. Cut a 1/8" slit for the engine hook between the marks, 1" from the end of the tube. Install the engine hook in place and align it between the two lines. Secure the rear end of the hook with a piece of tape temporarily.

(2) Make a mark 1-7/16" from the rear of the tube. Run a bead of glue all around the tube, about 1-1/2" from the front of the tube. In one continuous motion, slide the green adapter ring onto the front of the tube and down to the 1-7/16" mark. Wipe away any excess glue.

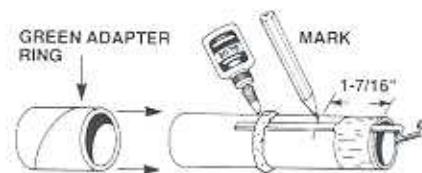

(3) Run a bead of glue around the inside front of the engine tube. Slide the tube coupler in until it touches the engine hook.

### RED BT-50 STAGE COUPLER



(4) Run a bead of glue around the inside of the main rocket body tube, about 1" from the rear. Insert the engine mount into the tube, then immediately push it into place by inserting and fully seating the fin unit

## LOOKDOWN ASTROCAM, MKII PARTS LIST

Heavy duty engine mount tube - HBT-1000-4	PN 031222*
AR-100056 Green adapter ring	PN 030135*
E engine hook EH-1A	PN 035030*
BT-50 tube coupler - KJT-50C	PN 30174-5*
Orange spacer ring - EC-75	PN 034998*
2-1/4" of BT-56 tube - blue tube	PN 030339**
1/4" Shock cord (24" - 36" long) elastic	EST2277
12" of shroud line	
PNC-56 nose cone - yellow	PN072014**
- blue	PN072016**

\* Parts marked with a single asterisk are all you will need if you wish to leave the camera unmodified but adapt the rocket for larger engines. Use D12-7 or E15-8 engines and launch at a slight angle from vertical. Better bring your sneakers and binoculars!

\*\* These parts can also be salvaged from a Maniac (EST2091) or Helicopter (EST1995). The Maniac will also have all the parts indicated by a single asterisk.

behind it. Remove the fin unit and set the engine mount/body tube assembly aside to dry in a horizontal position.



Once dry, cement the plastic fin unit in place behind the engine mount.

The rest of the rocket construction is pretty much per the instructions, except for substituting the 1/4" shock cord for the supplied 1/8". Be sure to set the shock cord mount at least 1-1/2" back from the front of the body tube to clear the new adapter which is longer than the stock one. I strongly recommend the use of 3/16" launch lugs and a Maxi-Rod for stability and consistency at launch, especially with E engines.

Locate the engine mount centering rings supplied with the kit. Cement the unslotted ring to the nose cone of the camera, taking care to get it as level as possible. Allow to dry. Next, test fit the 1-3/4" BT-56 tube over the ring and camera nose cone, and mark a line around the nose cone where the tube touches it. Remove the tube. Apply a bead of cement to the nose cone along the mark just made, also apply a bead of glue to the inside front edge of the tube. Push the tube into place, and wipe away excess glue. Apply a bead of glue around the inside rear of the tube, then push the red tube coupler in until it touches the centering ring. Allow to dry.

Pull the shutter cord straight down along the camera body, and make a mark on the red coupler where the cord lies, 1/4" down from where the coupler enters the BT-56 tube. Make another mark 1-1/4" to the side of this mark, the same distance from the

The following engines are suitable for this model:

Straight up shots	Oblique shots
E15-4	E15-6
D12-3	D12-5
<b>with EM-2050 adapter:</b>	
C6-3	C6-5
C5-3	
B6-2	

The B6-2 is good for low altitude shots that show the launch pad and surrounding site well. You might even get your smiling face in the picture - wave for the camera! The engine choices under the "straight up shots" column will deploy the parachute while the rocket is still moving at a fairly good rate of speed, so exercise due caution. Make sure the parachute is well construct-

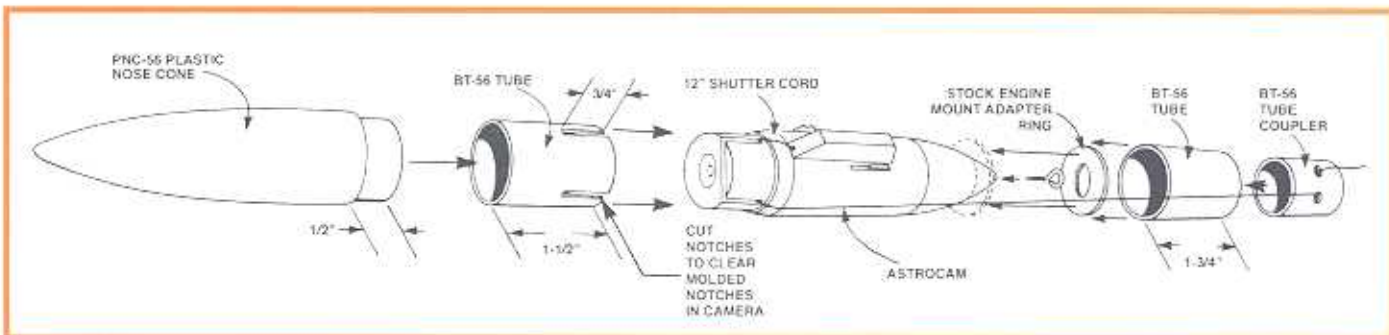

#### (5) Modifying the camera:

Cut two pieces of BT-56 tube - one 1-1/2" long, and one 1-3/4" long. Make sure the ends are cut square to ensure alignment.

Slide the 1-1/2" piece partway over the tube adapter of the Astrocam unit, and mark it in the two locations where the shutter cord slot is molded in. Cut two slots in the BT-56 tube to clear these slots - 1/4" wide, and 3/4" long. Test fit to make sure the slots in the camera tube adapter are exposed. Now cement the tube in place securely.

To keep the camera assembly as short and light as possible, cut away the base of the plastic nose cone, leaving 1/2" of shoulder remaining. Securely cement the nose cone in place in the slotted tube just installed.

front of the coupler. Using a sharp hobby knife, cut a 1/4" diameter hole at each mark, centered on the mark.

Now pull the cord down along the body, and feed it through the first hole, through the coupler and out the second hole. Cut the cord 2" out from where it exits the second hole, and tie a knot in the end to prevent fraying. That's it!

### LAUNCHING THE LOOKDOWN ASTROCAM®

The idea behind the Lookdown Astrocam® is to trip the camera while the rocket is still traveling upwards, otherwise you will get a nice picture of the sky. Therefore, you will use shorter delays than customary.

ed, the knots are secure, etc. The chute will open with a snap! Using the larger engines, you may want to cut a small spill hole in center of the chute to speed up the descent - 1" to 1-1/2" diameter should work well. I used a 4" x 72" streamer on my first model, however some damage to the nose cone and tube occurred on the first asphalt landing. Grass landings were okay. I think the chute is better if you have the space to fly with it.

I hope you have enjoyed these two articles. Build these models and fly them! By the way two other Estes kits that lend themselves to the modifications Bill outlined in his AstroCam MK II article are the HELIO COPTER (EST 1995) and the our new MANIAC (EST 2091). The MANIAC already comes configured for F engines!

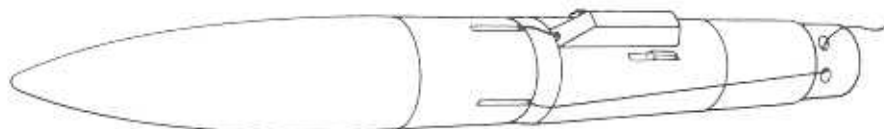

COMPLETED CAMERA (SIDE VIEW)

Editor.....Mike Hellmund  
 Art Director.....Kent Jodrie  
 Design.....Dave Talbot  
 © Copyright Estes Industries, 1994.  
 All rights reserved.



## Reunited with the Blackbird "Mother Ship"

# TOP-SECRET D-21 DRONE UNCLOSED AT SEATTLE'S MUSEUM OF FLIGHT

*From Museum of Flight Press Release*

SEATTLE, WASHINGTON, January 3, 1994: The Museum of Flight will soon boast the only exhibit of its kind in the world when a rare Lockheed D-21 drone is reunited with the Museum's supersonic A-12 Blackbird "mother ship." On permanent exhibit beginning Saturday, January 22, 1994, the Lockheed D-21 drone joins the sole remaining A-12 Blackbird aircraft in existence modified to carry it on classified aerial reconnaissance missions during the height of the Cold War.

Developed by the Lockheed Advanced Development Company ("Skunk Works") during the mid-1960s, the D-21 drone was originally designed for CIA surveillance missions over hostile territories. Capable of speeds approaching 3,000 mph, the 42-foot-long drone closely resembles the A-12 in both appearance and structure. Like the Blackbird, more than 95 percent of the drone's airframe is comprised of titanium.

Placed on long-term loan to the Museum of Flight by the U.S. Air Force, the D-21 drone (serial number 90-0510) has been stored at Davis-Monthan Air Force Base near Tucson, Arizona since the early 1970s.

For its relocation to Seattle, the drone was transported via truck, arriving at Boeing Field in November 1993. Over the past three months, the drone has been cleaned and prepared for public display aboard the A-12 Blackbird, which has been on exhibit in the Museum of Flight's Great Gallery since December 1991.

The history of the D-21 drone program dates to the early 1960s, when after initial flight tests at least five confirmed drone launches were made. On the final launch, one of the two A-12 Blackbirds modified for drone missions was destroyed in a mid-air collision. As only one drone-carrying A-12 remained -- the Museum of Flight's A-12 Blackbird, serial number 60-6940 -- Lockheed Skunk Works chief Kelly Johnson personally cancelled the A-12/D-21 program. Subsequently, D-21 drones were launched from Boeing B-52H's over the People's Republic of China. Those flights ended about the time President Richard Nixon visited Beijing in 1972, and shortly thereafter, the 17 remaining D-21 drones were placed in storage at Davis-Monthan AFB. (The last A-12/YF-12 aircraft was retired in 1979, while SR-71 Blackbird versions remained in use by the Strategic Air Command until March 1990.)

Only two of the 15 total A-12 Blackbirds built were modified to carry the drone, a modification which involved the installation of a second seat behind the pilot for the Launch Control Officer (LCO). The drone itself was mounted on a launch pylon on the aft fuselage of the Blackbird, and when the aircraft reached Mach 3, the LCO would launch the drone. The drone, able to travel at speeds approaching 3,000 mph, followed a pre-programmed flight path. Following its mission, it was guided to a predetermined site in friendly territory, and its reconnaissance data was ejected and recovered in the parachute descent by a C-130 Hercules transport aircraft sent to complete its task. Once the pick-up was completed, the drone self-destructed.

In addition to the Museum of Flight, four D-21 drones have been designated to NASA and two have been assigned to the National

Aerospace Plane Program (NASPP). Several others are being placed on display at military museums across the country, including the U.S. Air Force Museum at Wright-Patterson Air Force Base in Ohio.

The A-12/D-21 exhibit will open to the public Saturday, January 22, 1994 at the Museum of Flight, located 10 minutes south of downtown Seattle at Boeing Field, 9404 East Marginal Way South (Exit 158 from I-5), Seattle, WA 98108. Galleries are open daily from 10:00 a.m.-5:00 p.m., Thursdays until 9:00 p.m. Admission is \$6.00 adults, \$3.00 ages 6-15, and free for children under age 6 and Museum of Flight members. Visitor information is available by calling (206) 764-5720.

### D-21 DRONE SPECIFICATIONS:

Speed:	Mach 4
Ceiling:	100,000 feet+
Range:	3,000+ miles
Length:	42' 10"
Span:	19' 9"
Height:	7' 4"
Engine:	One Marquardt RJ43-MA-11 ramjet engine
Structure:	95 percent titanium
Weight:	4,600 lbs.
Gross Weight:	20,000 lbs.
Serial Number:	90-0510

### A-12 BLACKBIRD SPECIFICATIONS:

Speed:	Mach 3+
Ceiling:	80,000 feet+
Length:	98 feet
Span:	55.6 feet
Height:	18.5 feet
Engines:	Two Pratt & Whitney J-58 JT11D-20 turbo-ram jets
Structure:	95 percent titanium
Thrust:	32,500 pounds at sea level each
Gross Weight:	140,000 lbs.
Fuel Capacity:	80,000 lbs. (JP-7)
Serial Number:	60-6940

*Note: There are slight differences between the A-12 and SR-71 so you can use an Estes SR-71 as a basis for the conversion. How about a drone that separates and glides back?*

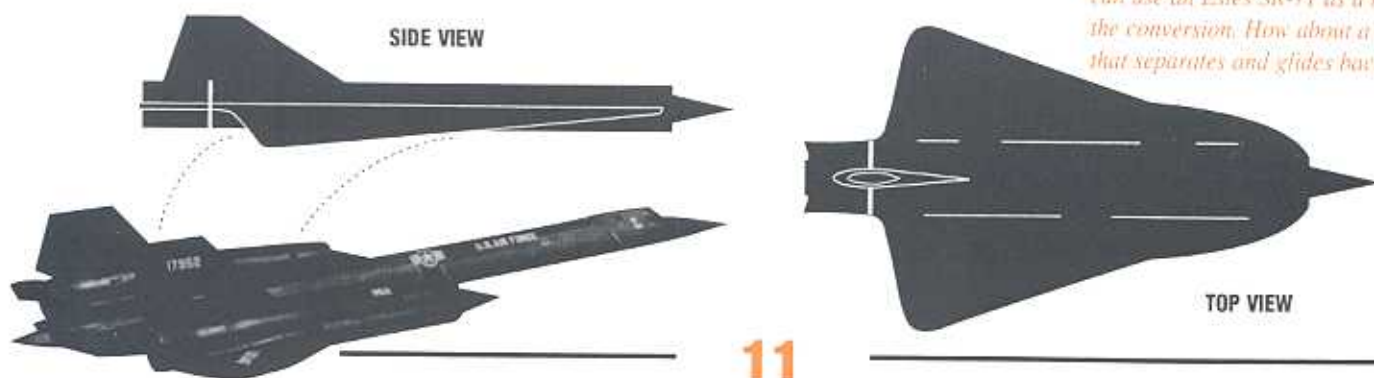

# TANGENTS

The following press release came from the Smithsonian Institute, concerning an extension to the National Air and Space Museum. If you have never been to this museum in Washington, D.C., it is well worth the visit - especially if you are interested in anything man-made that flies. The museum has an excellent rocket and space exhibit.



**BLAST OFF!**  
**WITH ESTES**  
*Flying Model Rockets*

Only ESTES Offers  
More Than 80 Exciting  
Model Rocket Kits!  
On Sale Everywhere. 

## Smithsonian Institution NEWS

### PRESIDENT CLINTON SIGNS LEGISLATION TO ESTABLISH NATIONAL AIR AND SPACE MUSEUM EXTENSION

President Bill Clinton signed legislation on Aug. 2, 1993, establishing an extension for the Smithsonian's National Air and Space Museum near Washington Dulles International Airport in Virginia. The 670,000-square-foot facility will provide the museum with adequate space to house and restore its collection of airplanes and spacecraft, many of which are too large for the museum on the National Mall in Washington, D.C.

The cost of the project is estimated at \$162 million, and the facility may open by the end of the decade, according to Museum Director Martin Harwit.

Among objects to be displayed in the new extension buildings will be the space shuttle Enterprise; the Enola Gay; the SR-71, the world's fastest airplane; a Lockheed Super Constellation long-range airliner; a Boeing B-17 Flying Fortress; a Concorde; and Apollo capsules.

"With the authorization for this extension, the Smithsonian has taken a major step in preserving this priceless history," Smithsonian Secretary Robert McC. Adams said. "The new facility will give us the opportunity to enrich the National Air and Space Museum's account of the scientific and technological achievements of the 20th century."

"We are delighted that the president has signed the bill authorizing the National Air and Space Museum to begin planning for an extension at Washington Dulles Airport," Harwit said. "This clears the way for the museum to plan for the stewardship of the collection."

The commonwealth of Virginia will provide all the infrastructure that has been requested by the Smithsonian, including preparation of taxiways, parking facilities, grading and highway access improvements. A \$3 million interest-free loan will be made available as will authority for a \$100 million bond issue. A cash donation of \$6 million will be provided by Virginia and a matching \$6 million will be provided by Virginia business enterprises.

The legislation signed by the president includes an authorization of \$8 million for detailed planning and design. However, the Smithsonian will continue the master planning phase for the extension with the \$350,000 that had previously been appropriated by Congress.

The master planning for what will serve as the display storage facility for the museum at Dulles is being completed by Heilmuth, Obata & Kassabaum, the firm that conducted site evaluations for the museum several years ago.



**ESTES INDUSTRIES**  
1295 H STREET  
PENROSE, CO 81240 USA

BULK RATE  
U.S. POSTAGE PAID  
ESTES INDUSTRIES