

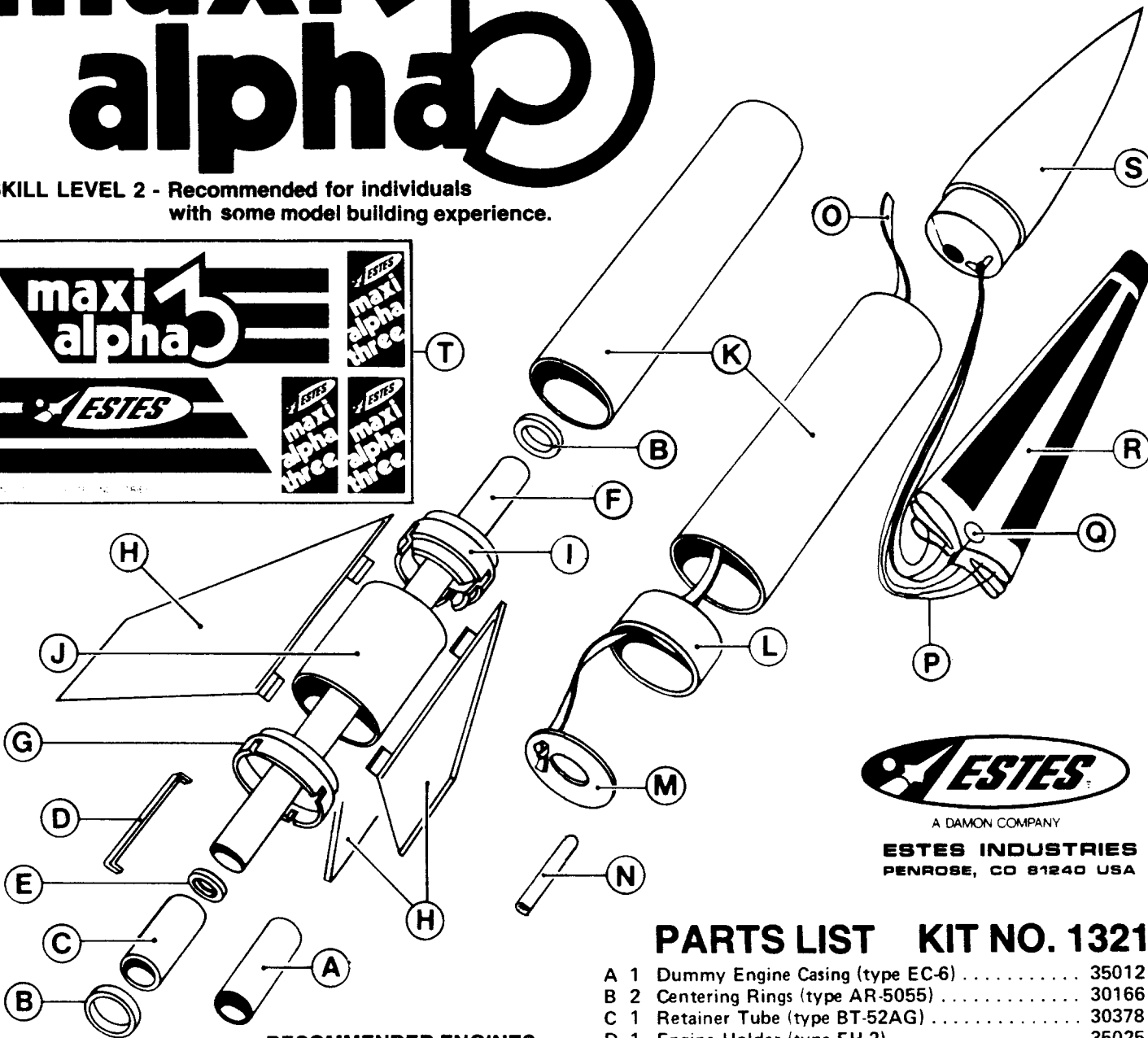

# maxi alpha 3

**SKILL LEVEL 2 - Recommended for individuals with some model building experience.**



**RECOMMENDED ENGINES:**  
D12-3 (First Flight), D12-5

## TOOLS AND MATERIALS

In addition to the parts included in this kit you will need "white" glue (such as Elmer's, Wilhold, etc.), a modeling knife, masking tape, fine sandpaper, pencil, ruler, & gloss red enamel spray paint.

## BEFORE YOU START

**IMPORTANT:** Read each assembly step thoroughly before doing the work for that step. Test fit parts before applying any glue. If necessary, lightly sand the inside edge of the tube ends to insure a good slip fit. Do not attempt to build this model with any cement other than the type indicated above.



A DAMON COMPANY

**ESTES INDUSTRIES**  
PENROSE, CO 81240 USA

## PARTS LIST KIT NO. 1321

A	1	Dummy Engine Casing (type EC-6)	35012
B	2	Centering Rings (type AR-5055)	30166
C	1	Retainer Tube (type BT-52AG)	30378
D	1	Engine Holder (type EH-2)	35025
E	1	Engine Block (type AR-2050)	30164
F	1	Engine Tube (type BT-50L)	30366
G	1	Bottom Fin Ring	33212
H	3	Fins	33210
I	1	Top Fin Ring	33211
J	1	Short Body Tube (type WBT-80MA)	30431
K	2	Long Body Tubes (type WBT-80A)	30429
L	1	Tube Coupler (type JT-80C)	30274
M	1	Die-Cut Ring (type TA-1321)	30170
N	1	Launch Lug (type LL-3B)	38166
O	1	Shock Cord (type SC-2MJ)	85738
P	1	Shroud Line (type SLT-144)	38241
Q	6	Tape Discs (type TD-3F)	38406
R	1	Parachute (type PK-24A)	85568
S	1	Nose Cone (type PNC-80K)	71035
T	1	Decal (type KD-1321)	37135

# ASSEMBLY INSTRUCTIONS

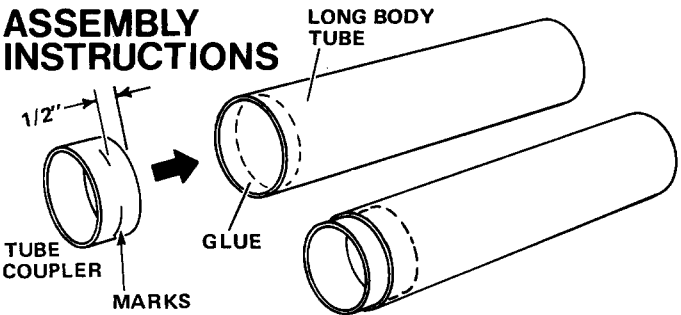

**1** Mark the tube coupler (part L) in the middle (1/2" from one end). Put 3 or 4 marks around coupler so it can be positioned straight in the body tube. Run a bead of glue around the inside of one end of one 9" long body tube (part K). Push the coupler into the tube until the marks on the coupler line up with the end of the tube. Wipe away excess glue and set aside to dry.

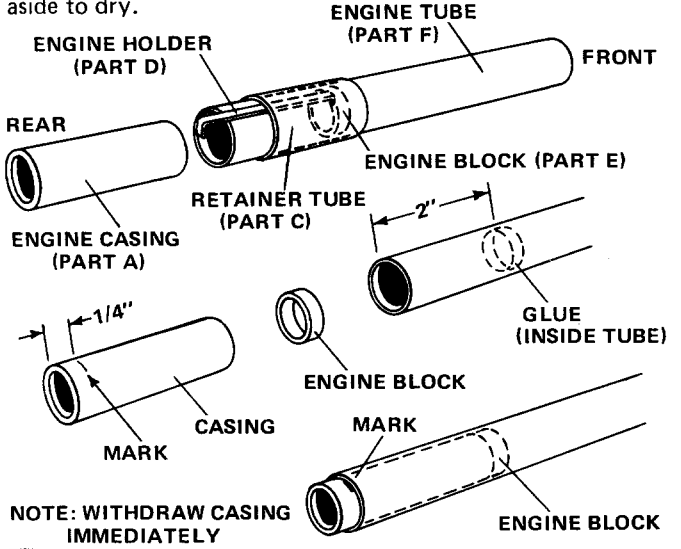

**NOTE: WITHDRAW CASING IMMEDIATELY**

**2** Locate the parts shown in the illustration. Place a mark on the engine casing 1/4" from one end. Using a small stick, apply a bead of glue inside one end of the engine tube approximately 2" from the end. Insert the engine block into this end of the tube and use the engine casing to push the block into place (with mark on casing even with end of engine tube). Withdraw casing immediately so it will not be accidentally glued into tube.

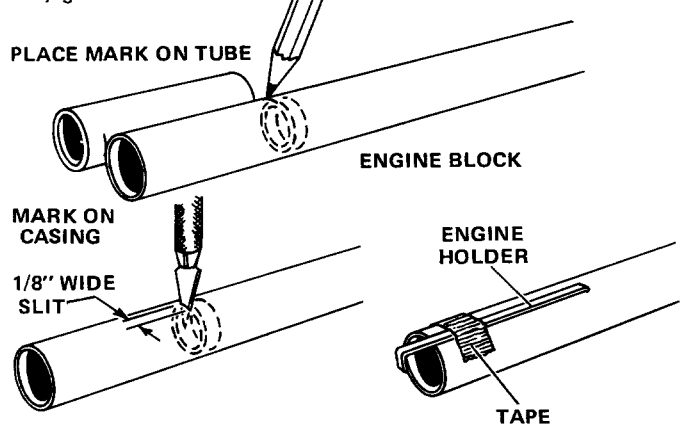

**3** The engine holder is attached to the engine tube with one of its hooked ends against the engine block. To locate, hold the casing against the outside of the engine tube with the mark on the casing even with the end of the tube. Place a mark on the tube even with the top of the casing. Cut a 1/8" wide slit in the tube on the pencil mark. Insert one end of the engine holder into slit. Align holder with tube and temporarily secure with a piece of masking tape around bottom of tube.

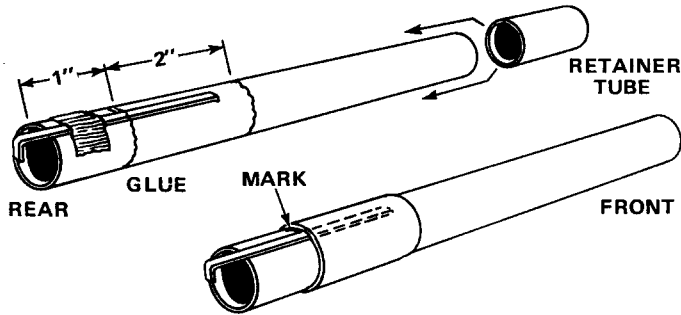

**4** Place a mark on the engine tube 1" from the end. Smear a film of glue around the tube above this mark for a distance of 2". Make sure you have glue all around the upper portion of the engine holder. Slide the retainer tube onto the opposite end of the engine tube. Push the retainer down until it reaches the 1" mark. Wipe away excess glue.

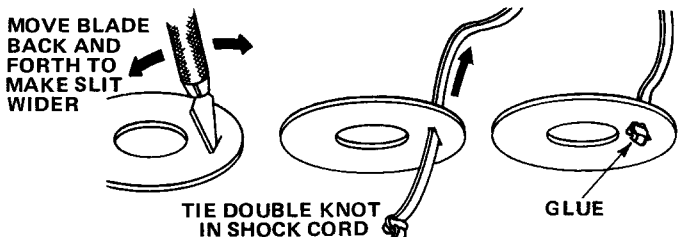

**5** Use a knife blade to slightly widen the slit in the die-cut ring (part M). Insert one end of the shock cord (part O) through the slit. Tie a double knot in the end of the shock cord and pull it tight against the ring. Smear glue over the knot to secure it in place.

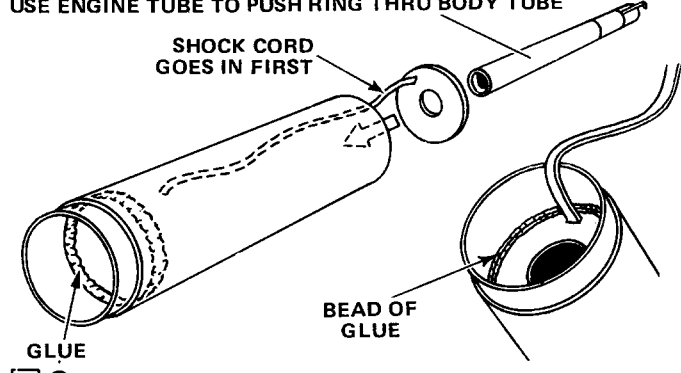

**6** Locate the body tube and coupler which you glued together in step 1. Apply a bead of glue around the inside of the body tube at the base of the coupler. Insert the die-cut ring into the opposite end of the body tube with the shock cord extending through the body first (as shown). Use the engine tube to push the ring through the body-tube until the ring is tight against the bottom of the coupler. Apply a second bead of glue around the ring-coupler joint and set aside to dry.

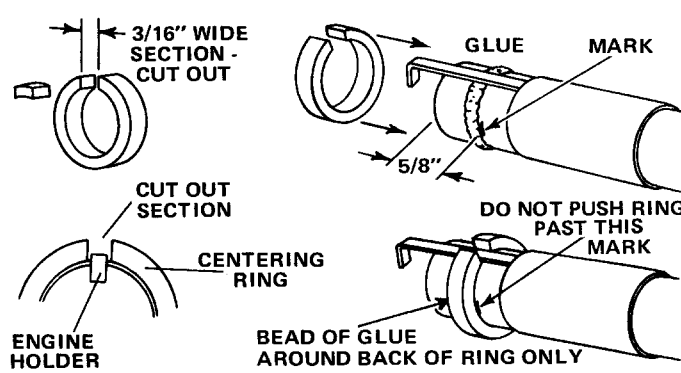

**7** Cut a 3/16" wide section from one of the centering rings (part B). Place a mark on the engine tube 5/8" from end. Apply a bead of glue around tube in rear of mark. Don't get

glue on engine holder. Push the centering ring into place with the front of the ring even with the mark. The cut-out section of the ring should be centered on the engine holder. The holder must be able to flex outward without interference from the ring. Run a bead of glue around bottom ring-tube joint for added strength. Do not put any glue on the front of the ring.

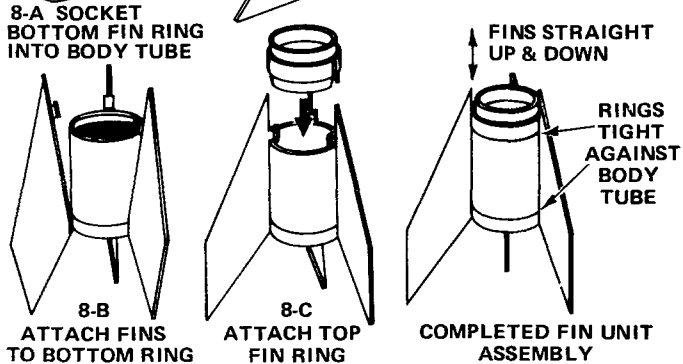
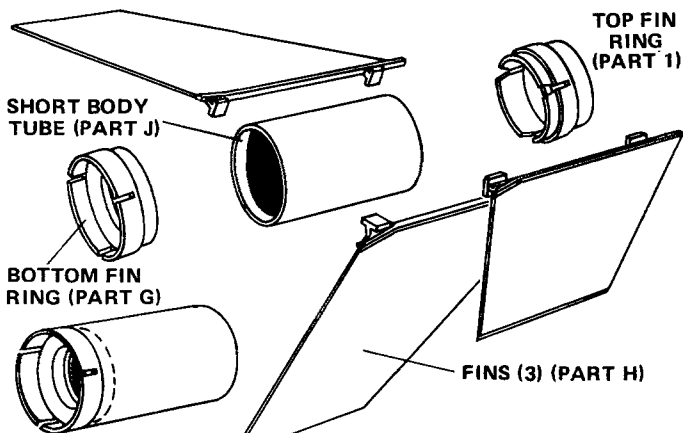

**8** Locate the parts shown in the illustration. Socket the bottom fin ring into the short body tube. Push the bottom attachment lug of each fin into one of the slots in the bottom ring. Pull the tops of the fins into against the body tube and attach the top fin ring. The attachment lugs on the fins will first engage the slots in the top ring. Push the ring down until the bottom portion of the ring is socketed into the body tube. Make sure both rings are firmly socketed into the body tube. Check the vertical alignment of the fins with the body. If they do not appear to be exactly straight up and down, slightly twist the top fin ring to bring them into alignment.

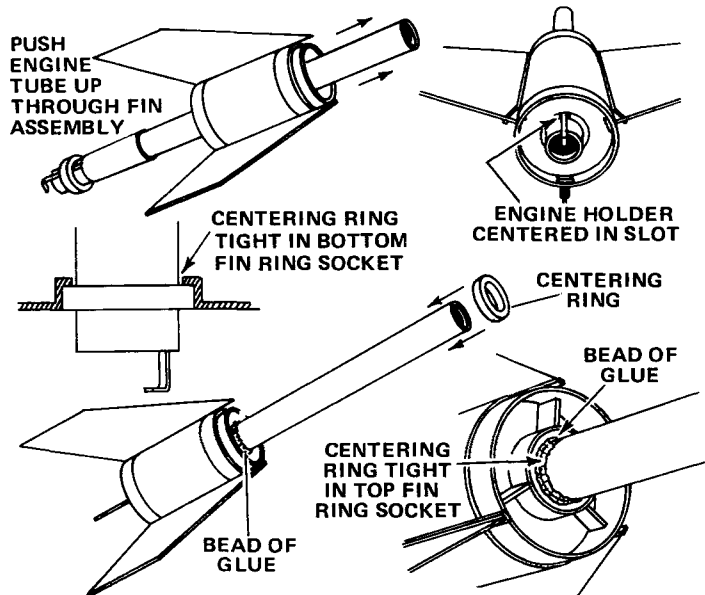

**9** Slide the engine tube assembly up through the fin assembly as shown. Note that the engine holder must be centered

in the slot in the bottom fin ring. Push the engine tube up until the centering ring is tight in the bottom fin ring socket. Apply a bead of glue around the engine tube just above the top fin ring. Slide the remaining centering ring over the top end of the engine tube and push it down until it is tight in the top fin-ring socket. Make sure the fin assembly is still pressed firmly together. For added strength, apply a bead of glue around the centering ring-body tube joint. Set aside to dry.

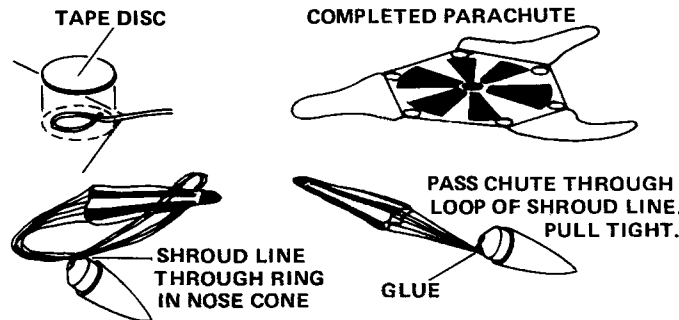

**10** Cut out the parachute (part R) along its edge lines. Cut the shroud line (part P) into three equal (48") lengths. Attach the ends of the lines to the parachute with the tape discs (part Q). Make sure the lines form a complete loop at the ends and that the tape discs are pressed firmly in place. Pass the shroud line loops through the attachment ring of the nose cone (part S). Pass the parachute through the loop ends and draw the lines tight against the nose cone ring. Set the knot with a drop of glue.

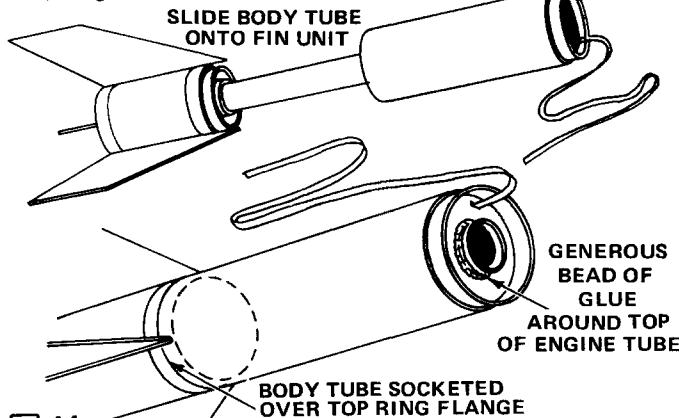

**11** Slide the body tube assembly onto the fin unit. The bottom of the body tube should be socketed over the upper section of the fin ring and the engine tube should extend through the die-cut ring at the top of the body. Make sure the whole unit is pushed tightly together, then apply a generous bead of glue to the engine tube where it protrudes through the die-cut ring. Set the assembly aside and do not disturb until glue is completely set.

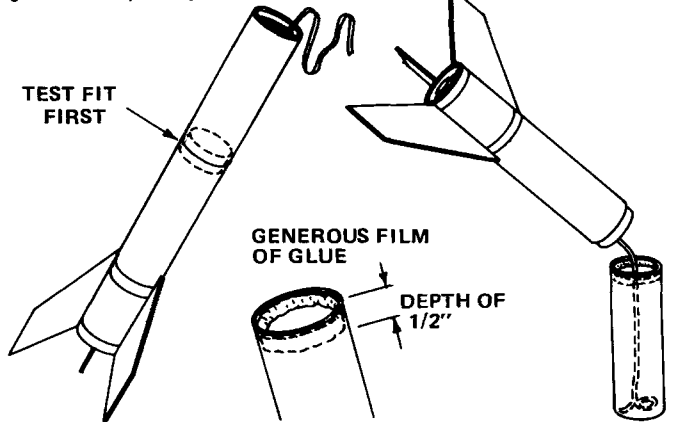

**12** After the glue has dried on the main rocket assembly, attach the remaining body tube. Test fit the tube on top the assembly. If necessary, lightly sand the inside edge of the tube

# LAUNCHING COMPONENTS

To launch your rocket, you will need the following items:

-An Estes model rocket launching system fitted with a heavy duty launch rod (Estes Cat. No. 2239). Make sure the launch platform is securely "tied down" as described in the launcher instructions.

-Parachute recovery wadding (Estes Cat. No. 2274).

-Estes D12-3 or D12-5 model rocket engines. (Estes Cat. No. 1666 and 1667.)

**IMPORTANT---IMPORTANT---IMPORTANT**

Be sure to follow the "HIAA-NAR Model Rocketry Safety Code when carrying out your model rocketry activities.

\*HIAA-NAR — Hobby Industry Association of America  
National Association of Rocketry

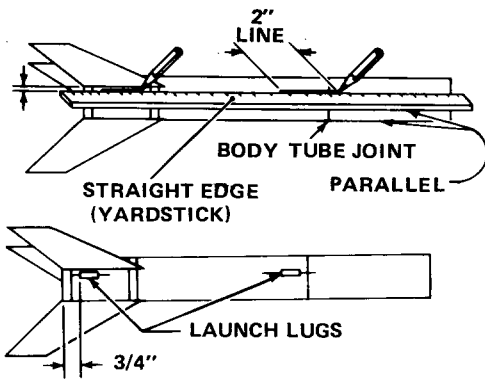

**13** Cut the launch lug (part N) into two 1" lengths. Place a mark near the rear of the rocket 1/4" from one fin. Place a long straight-edge (a yardstick if available) on the body. Line up on the mark, then sight down on straight-edge to make sure it is parallel with the edge of the body. Draw two short lines in the positions shown. Apply glue to one launch lug and attach to body, centered on the line, 3/4" from rear of rocket. Glue the remaining launch lug just behind the joint between the long body tubes. Allow the glue to become tacky, then lay the straight-edge on the body against the lugs. Make sure both lugs are aligned exactly against the straight-edge. Remove straight-edge and allow glue to dry. For added strength, apply a bead of glue to both sides of each lug.

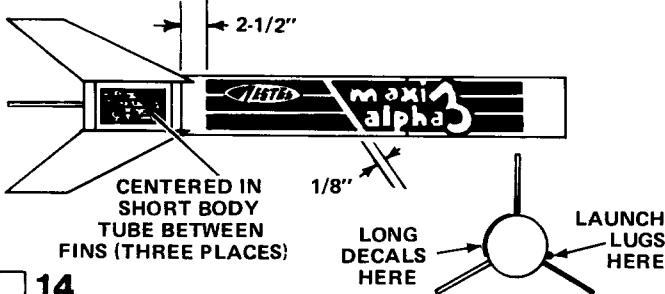

**14** Place a wood dowel in the opening in the nose cone end. Push a plastic bag over the end of the dowel. Push the bag down to the nose cone shoulder. Place the parachute and shroud lines in the bag and tape the bag to the front edge of the shoulder to protect the parachute and shoulder from paint "overspray". Spray paint the nose cone with several light coats of gloss red enamel. Allow the paint to dry overnight.

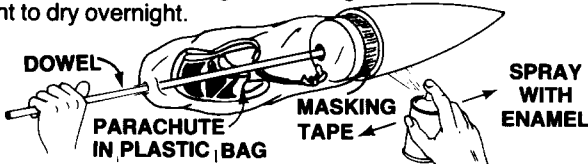

**NOTE:** Nose cone should separate easily from rocket body tube, but should not be extremely loose. If fit is too tight, sand inside of body tube and shoulder of nose cone with fine sandpaper. If fit is too loose, add a wrapping of masking tape to the shoulder of the nose cone.

**15** Apply the decals in the positions shown. Note that the long decal (in two pieces) is centered above the two fins opposite the side to which the launch lugs are attached. To apply decals, cut out individual decal, dip in water for 20-30 seconds (until decal slides off backing). Slide decal from backing paper onto desired surface. Blot dry with a clean damp cloth.

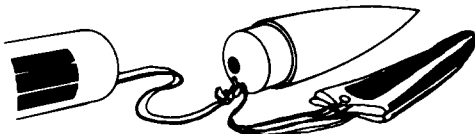

**16** Tie the free end of the shock cord to the nose cone attachment ring. Tie a good triple knot so it won't come loose. Insert chute, shock cord into body and socket nose cone in place Your Maxi Alpha 3 is now complete.

# COUNTDOWN CHECKLIST

**T-13** Pack 12 to 14 squares of loosely crumpled Estes Recovery Wadding into main body tube. The wadding should fill the bottom of the parachute compartment for at least two inches.

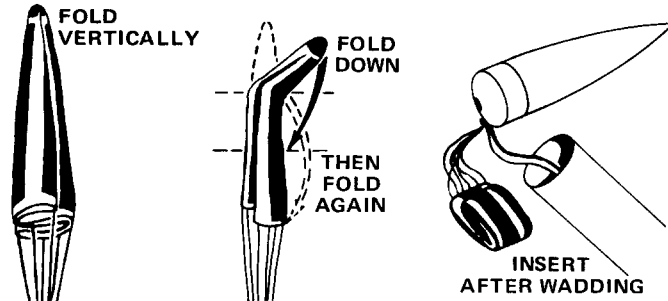

**T-12** Loosely fold the parachute. Lay it on top of the wadding, with its shroud lines and shock cord on top of it. Slide the nose cone into place.

**NOTE:** DO NOT pack parachute until you are actually ready to launch. For maximum parachute reliability, lightly dust the parachute with ordinary talcum powder before each flight, especially in cold weather.

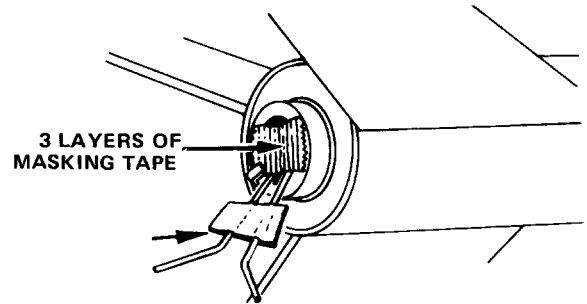

**T-11** Install an igniter in a D12-3 engine as directed in the engine instructions. Insert engine into the engine mount. Make sure the engine hook latches securely over the end of the engine.

**T-10** Disarm the launch panel -- REMOVE SAFETY KEY!

**T-9** Lower the rocket into position on the launch rod. (A 3/16" diameter launch rod is required.) Clean the micro-clips and attach one to each lead of the igniter. The clips must not touch each other, and the igniter leads must not cross.

**T-8** Clear the launch area, alert recovery crew and trackers.

**T-7** Check for low flying aircraft and unauthorized persons in recovery area.

**T-6** Arm the launch panel -- INSERT SAFETY KEY!

**-5-4-3-2-1-LAUNCH!!**

# MISFIRE PROCEDURE

Occasionally the igniter will heat and burn into two pieces without igniting the engine. This is almost always caused by a failure to install it correctly. Disarm the launch panel, remove the model, clean the igniter residue from the nozzle and install a new igniter. Follow the launching procedure again.





# maxi alpha 3

NEARLY  
3 FEET  
TALL!

## FLYING MODEL ROCKET

SKILL LEVEL 2

1-Beginner 2-Intermediate 3-Craftsman  
4-Advanced 5-Expert

Very easy-to-assemble giant scale version of one of our most popular kits. Can be ready-to-launch in approximately 30 minutes. Features new press-fit plastic fin-unit plus plastic nose cone. "D" engine powered for truly spectacular flights up to 500 feet. Perfect for demonstrations. Really dramatic recovery via huge 24" parachute. Nose cone, fin-unit, and body tube are all pre-colored. No painting required! Includes big kit decals and quick-release engine mount too. A 3/16" launch rod is recommended for lift-off.

PAINTING  
REQUIRED

Perfect for  
Demonstrations!

#### Specifications:

Length 33.25" (84.46 cm)

Diameter 2.6" (66.04 mm)

Weight 7.4 oz. (210 g)

24" Parachute Recovery

Recommended Engine:

D12-3

This is a hobby kit requiring assembly. Recommended for ages 10 to adult. Engines, launch system, glue and finishing supplies are not included. Adult supervision is suggested for those under 12 years of age when flying model rockets.

**ESTES**

A DAVON COMPANY

ESTES INDUSTRIES  
GENUINE, COLOR, BUILT U.S.A.

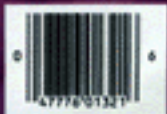

#1321



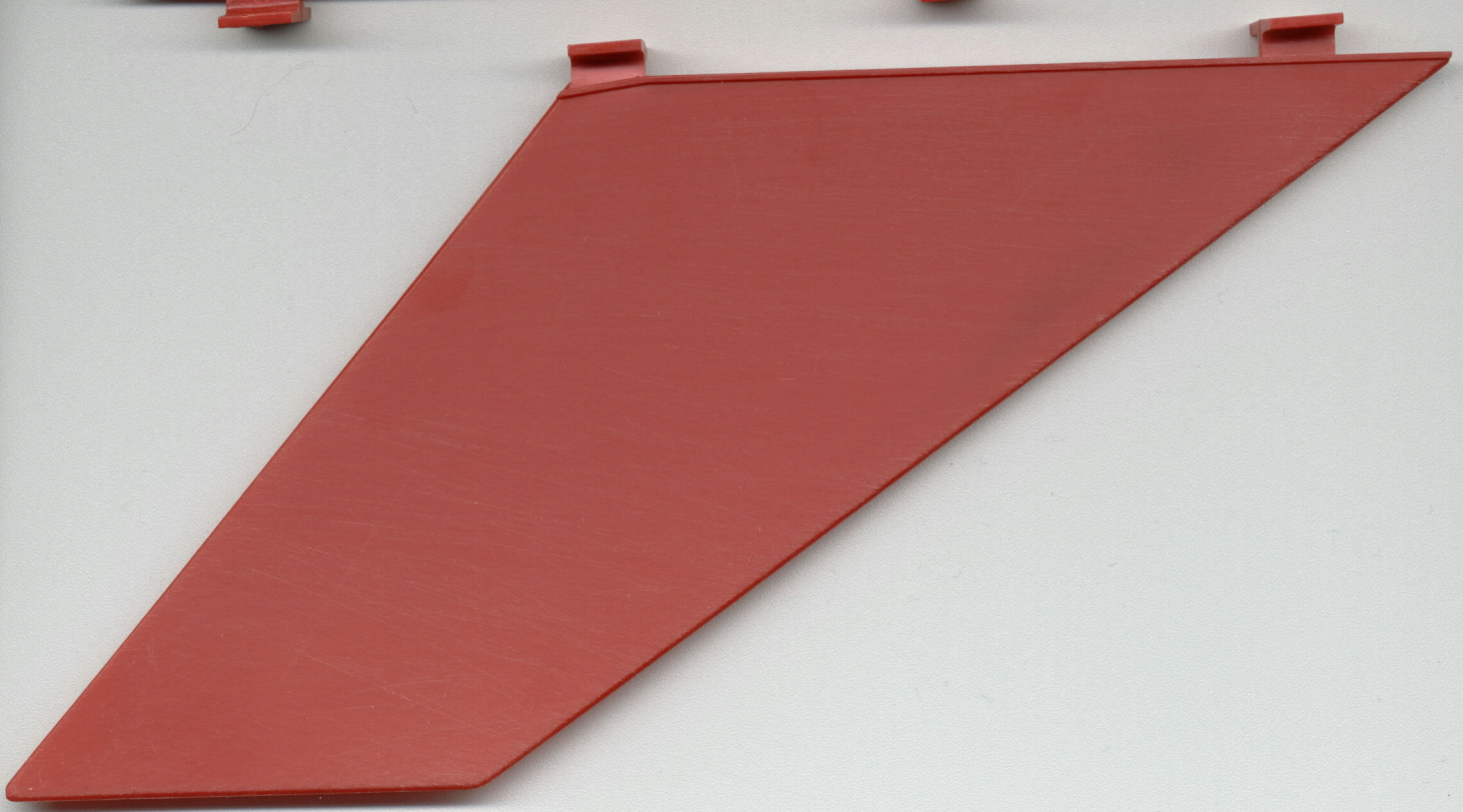



# maxi alpha



three  
alpha  
maxi!  
ESTES

three  
alpha  
maxi!  
ESTES

three  
alpha  
maxi!  
ESTES