



Searcher

SKILL LEVEL 2 - Recommended for Intermediate Rocketeers



A DAMON COMPANY

ESTES INDUSTRIES
PENROSE, CO 81240 USA

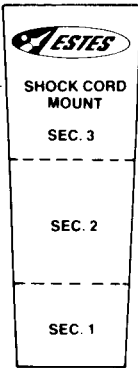
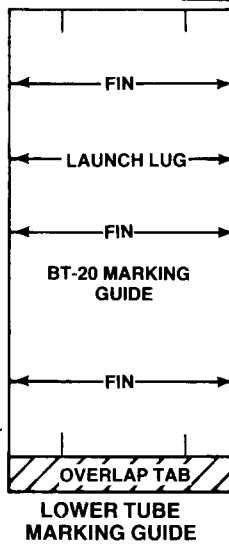
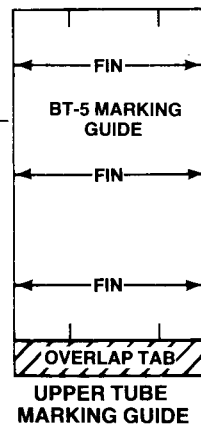
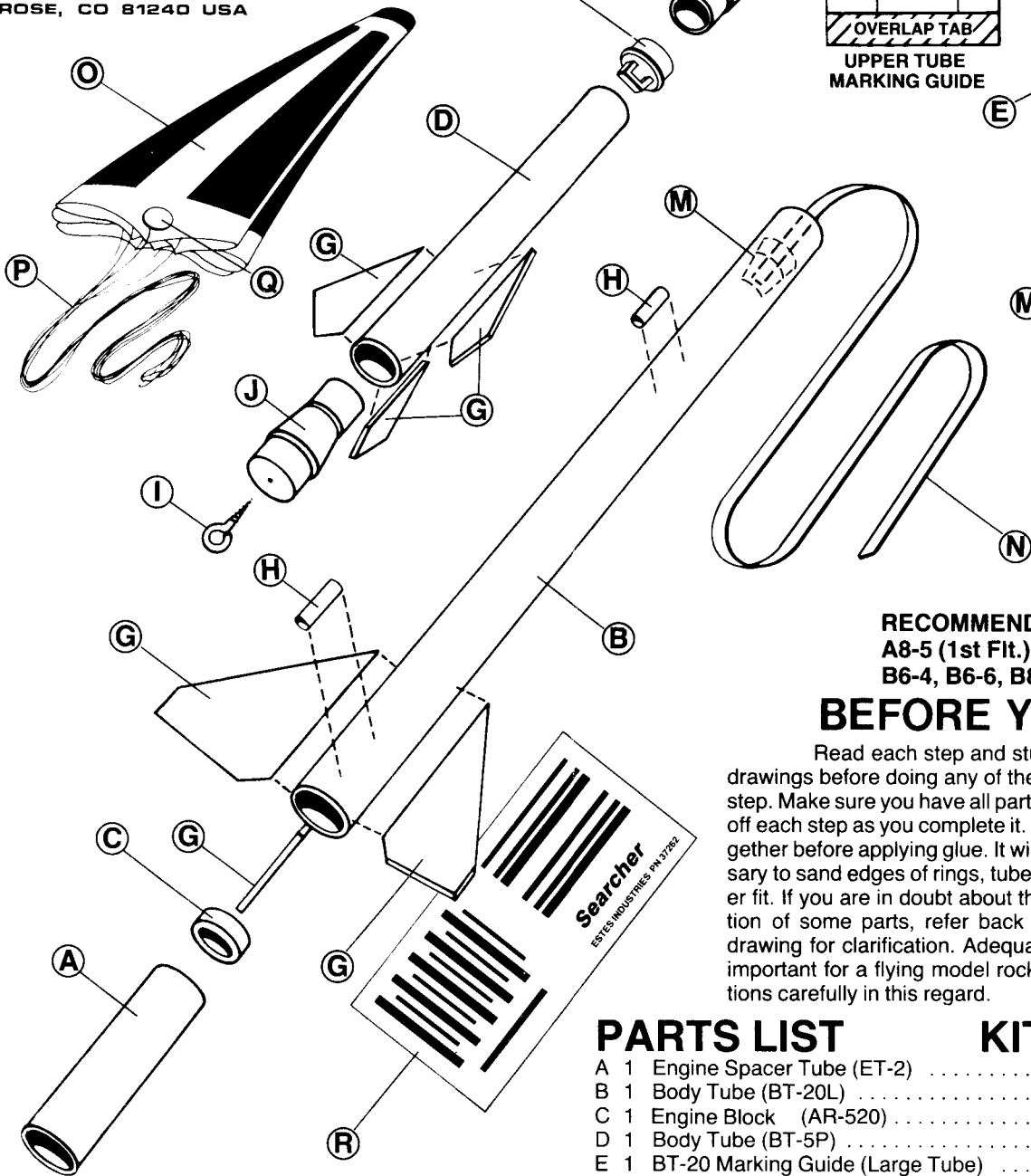

RECOMMENDED ENGINES
A8-5 (1st Fit.), B4-4, B4-6
B6-4, B6-6, B8-5, C6-5, and C6-7.

BEFORE YOU START

Read each step and study the accompanying drawings before doing any of the work called for in that step. Make sure you have all parts and materials. Check off each step as you complete it. Always test-fit parts together before applying glue. It will sometimes be necessary to sand edges of rings, tubes, etc. to obtain a proper fit. If you are in doubt about the relative size or location of some parts, refer back to this exploded view drawing for clarification. Adequate glue joints are very important for a flying model rocket. Follow the instructions carefully in this regard.

TOOLS AND MATERIALS

In addition to the parts included in this kit you will need: Scissors, household white glue (Elmer's, Titebond, or similar), plastic glue, pencil, ruler, fine or extra-fine grit sandpaper, sanding sealer, a medium-size modeling paint brush, modeling knife with sharp blade, gloss white, yellow, and gloss grey enamel spray paints, and Testor's "Gloss Cote".

For easy and positive alignment of the fins on your model, we recommend the use of Estes' Fin Alignment Guide, Part No. 2231.

PARTS LIST

KIT NO. 1945

A	1 Engine Spacer Tube (ET-2)	35003
B	1 Body Tube (BT-20L)	30330
C	1 Engine Block (AR-520)	30162
D	1 Body Tube (BT-5P)	30306
E	1 BT-20 Marking Guide (Large Tube)	on page 1
F	1 BT-5 Marking Guide (Small Tube)	on page 1
G	1 Die-Cut Balsa Fin Sheet (BF-1945)	32645
H	1 Launch Lug (LL-2A)	38175
I	1 Screw Eye (SE-2A)	38252
J	1 Balsa Adapter (TA-520)	70002
K	1 Plastic Nose Cone (PNC-5A)	72600
L	1 Nose Cone Insert (PIN-5A)	72601
M	1 Shock Cord Mount	on page 1
N	1 Shock Cord (SC-1)	85730
O	1 Parachute (PK-12A)	85564
P	1 Shroud Line (SLT-72)	38237
Q	1 Tape Discs Set (TD-3F)	38406
R	1 Decal (KD-1945)	37262

ASSEMBLY INSTRUCTIONS

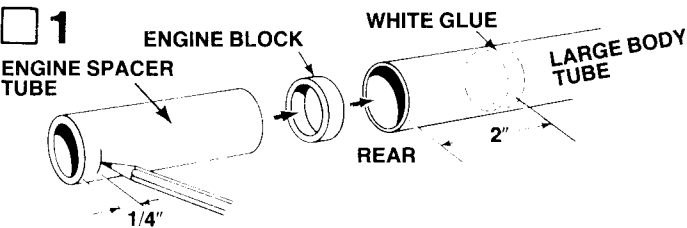

1 Mark the engine spacer tube (part A) 1/4" from one end. Spread a 1/2" wide band of glue around the inside of the large body tube (part B) about 2" in from one end. Insert the engine block (part C) into this end. Push the engine block into place with the engine spacer tube until the mark on the tube is even with the end of the body tube. **CAUTION:** Once you have started to push the block forward, **DO NOT STOP** until it is in place, and then (**REMOVE SPACER TUBE IMMEDIATELY!**).

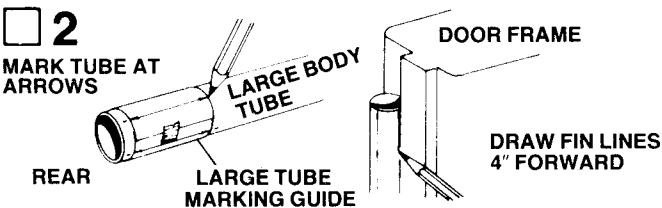

2 Cut out the body tube marking guides found on page 1 of the instructions (parts E & F). Wrap the large guide (part E) tightly around the large body tube. **BE SURE YOU WRAP MARKING GUIDE AROUND END THAT ENGINE BLOCK WAS INSTALLED IN.** Align the guide lines and tape the guide together. Mark the fin lines and launch lug line on the body tube where the arrows indicate. Remove the guide. Press the body tube firmly against the inside of a door frame as shown. Extend a line through each pair of fin marks 4" up from the rear. Extend the launch lug line the full length of the large body tube. Repeat this process with the small body tube (part D) and small body tube marking guide (part F).

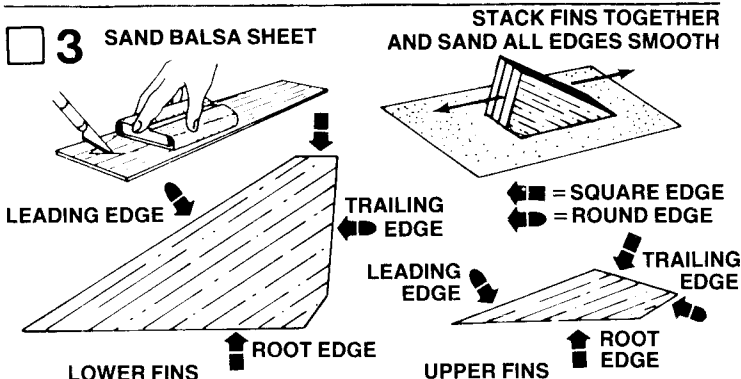

3 **SAND Balsa SHEET** Fine-sand the balsa die-cut sheet (part G). Free the fin edges with a sharp knife, then carefully remove the die-cut fins from the sheet. Stack fins together as shown and sand all four sides as illustrated. Lightly sand both sides of each fin. Sand the leading edge and trailing edge of each fin to make them round. Leave the root (body) edge sanded "flat". The root edge may be identified by careful comparison with the drawings. Sand large fins first, then sand the small fins separately.

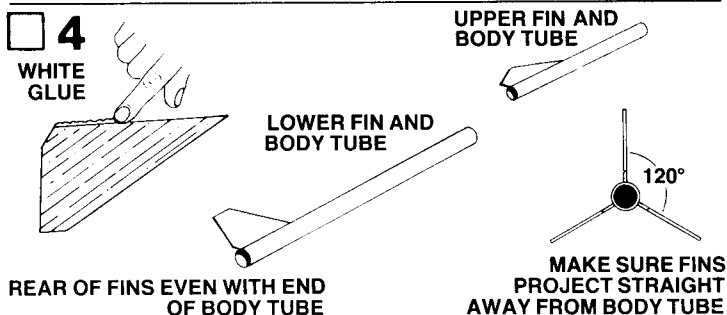

4 Rub a line of glue into the root (body) edge of each lower (large) fin. Allow the glue to dry. Glue the large fins to the large body tube so that

they are even with the rear of the large body tube. Repeat this procedure with the upper (small) fins and body tube. Be sure that the leading edge (the edge that is parallel to the wood grain direction) is to the front of each body tube as shown. Adjust each set of fins so they project straight away from the body tube. Set each body tube on a horizontal surface until the glue dries. Do not rest the rocket sections on their fins while they dry.

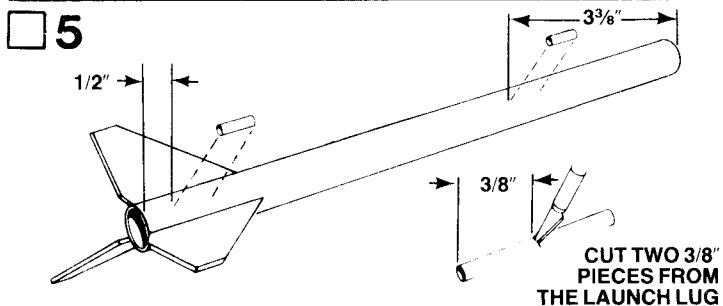

5 Cut two (2) 3/8" pieces from the launch lug (part H) with a modeling knife or single edge razor blade. Make marks on the lower (large) body tube launch lug line at 1/2" from the rear, and 3/8" from the front. Glue the launch lugs in place as shown in the illustration.

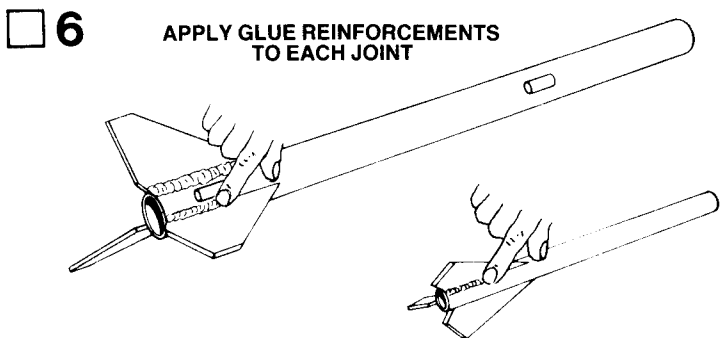

6 **APPLY GLUE REINFORCEMENTS TO EACH JOINT** When the glue on the fin joints and launch lugs has dried, apply a glue reinforcement to each joint. Holding the model level, apply a narrow line of glue to both sides of each fin joint and the launch lugs. Smooth out the glue with your finger. Be sure there is no excess glue in front of or behind the launch lugs. Keep the sections level until the glue dries.

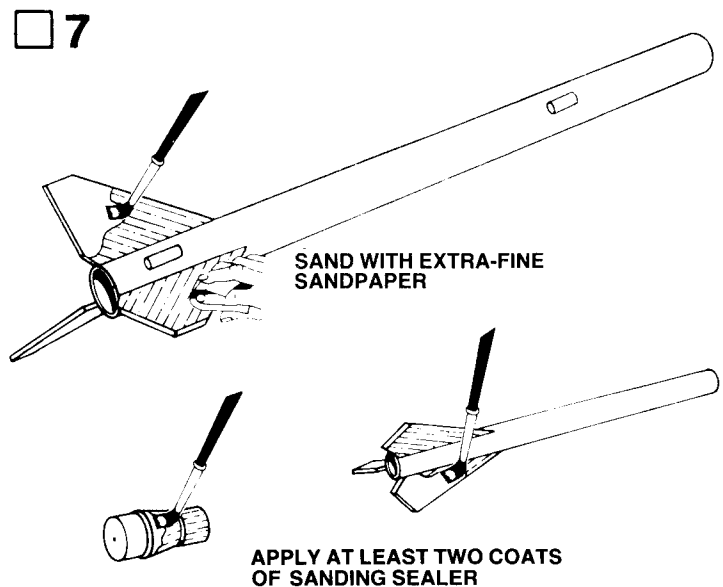

7 **SAND WITH EXTRA-FINE SANDPAPER** When all the glue on the model is dry, prepare the balsa parts for painting. Apply at least two coats of sanding sealer to all balsa surfaces. Let dry and sand thoroughly with the extra-fine grit sandpaper after each coat. Do this until all the tiny grain lines in the wood are filled and everything looks and feels smooth. The balsa adapter (part J) should be done at this time also.

8

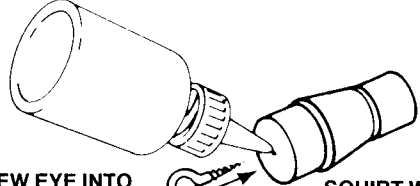

TURN SCREW EYE INTO ADAPTER AND REMOVE
SQUIRT WHITE GLUE INTO HOLE AND REPLACE SCREW EYE

Twist the screw eye (part I) into the center of the large end of the balsa adapter and remove. Squirt white glue into the hole and replace the screw eye.

9

APPLY PLASTIC CEMENT TO INSIDE OF NOSE CONE

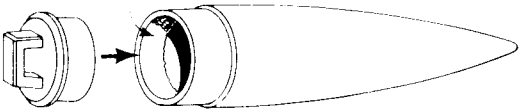

TWIST NOSE CONE BASE INTO PLACE

Apply plastic glue into rear end of nose cone (part K). Twist nose cone base (part L) into nose cone so it seats snugly against rear edge of nose cone.

10

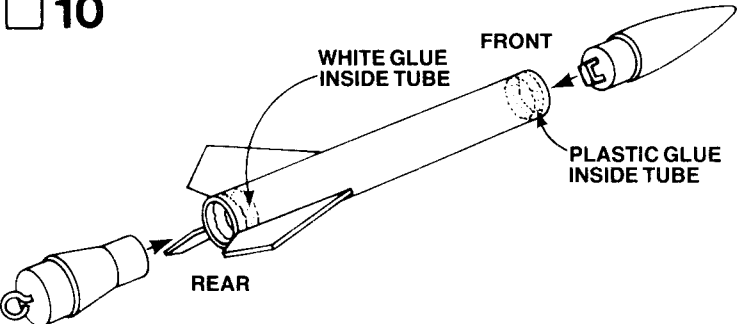

Apply a bead of white glue to the inside of the rear of the upper (small) body tube. Push the small end of the balsa adapter into this end. Apply a bead of plastic glue to the inside of the front of this body tube and twist the nose cone into this end. Place the assembly aside to dry.

11

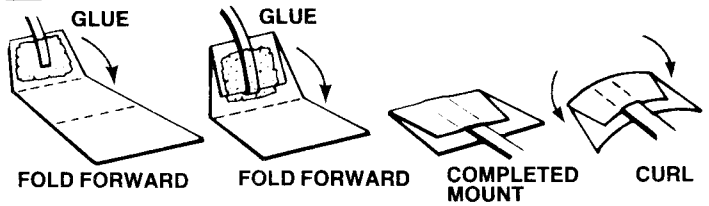

Cut out the shock cord mount (part M) found on page 1. Fold on dotted lines, then unfold and apply glue to Section 1. Lay the end of the shock cord (part N) into the glue. Fold over and apply glue to the back of Section 1 and the exposed portion of Section 2. Fold again to complete mount. Curl the edges of the mount down so it will match the contour of the body tube and hold with your fingers until the glue sets.

12

SET BACK TO ALLOW FOR NOSE CONE

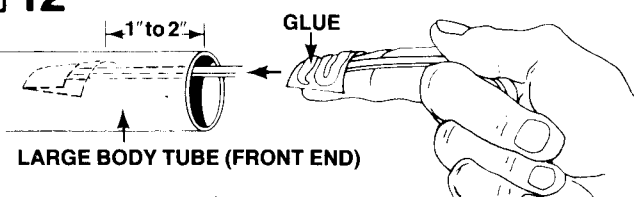

LARGE BODY TUBE (FRONT END)

Apply glue to the side of the shock cord mount which will go against the body tube. Press the shock cord mount firmly into position about 1" to 2" from the front edge of the large tube to allow clearance at the front of the tube for the adapter to socket into place. Slide the shock cord mount into the tube and press it firmly against the body tube. To insure a good bond use a stick or your finger to smear a film of glue over the mount and surrounding area in the body tube. Again firmly press the shock cord mount against the body tube and rub the glue over the mount and the body tube surface around it.

13

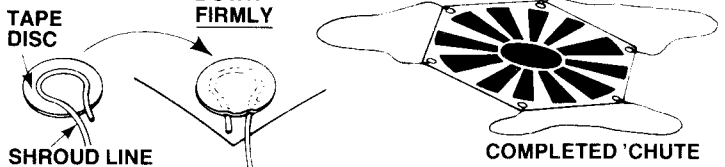

Cut out the parachute (part O) on its edge lines. Cut three equal lengths of shroud line (part P). Attach line ends to the top of the parachute with tape discs (part Q) as shown. Form a small loop in the end of a shroud line. Holding loop, gently center loop inside tape disc on the sticky side. Then carefully press tape disc onto its proper place on the top of the parachute. Firmly press the tape disc into place until both tape disc and parachute material are molded around the shroud line loop. Repeat for other shroud line ends and tape discs. Set completed parachute aside until needed in Step 15.

14

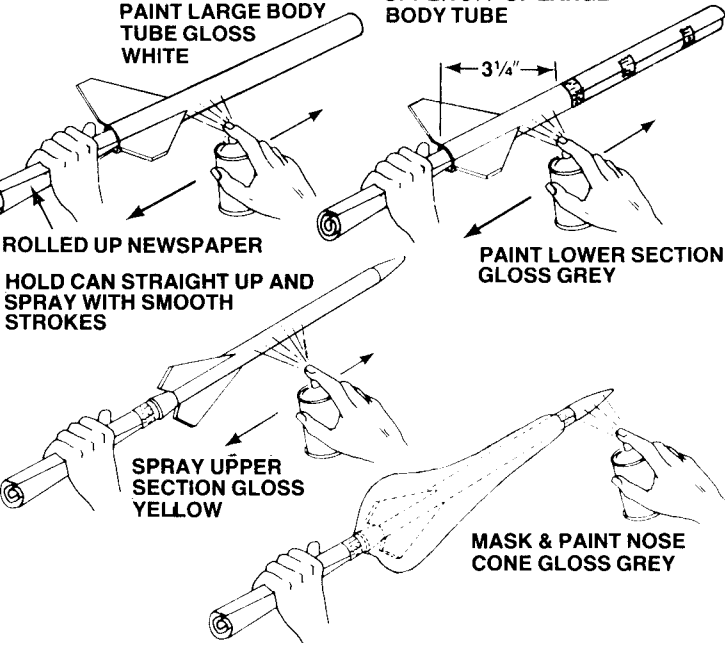

Insert a sheet of rolled-up newspaper or heavy paper into the lower body section as shown. Spray the lower section with two light coats, and one finish coat of gloss white spray paint. Allow the paint to dry overnight. Now apply a strip of masking tape 3/4" from the rear of the lower section around the body. Tape a piece of paper on top of this tape strip to protect the upper part of the body from overspray. Paint the lower part of the lower section gloss grey. Mask the shoulder of the adapter with masking tape, and tape a piece of newspaper to the masked shoulder to serve as a handle. Paint the upper section gloss yellow and allow to dry. Mask off the nose cone as shown and paint it gloss grey.

15

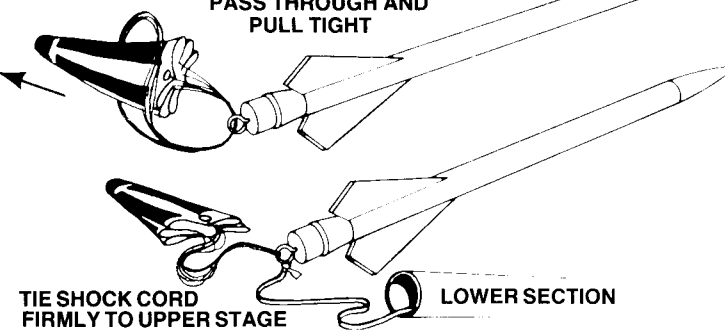

Pass the shroud line loops through the screw eye on the upper section. Pass the parachute through the loop ends and pull the lines tight against the screw eye. Tie the free end of the shock cord firmly to the screw eye. A square knot or strong double knot should be used.

16

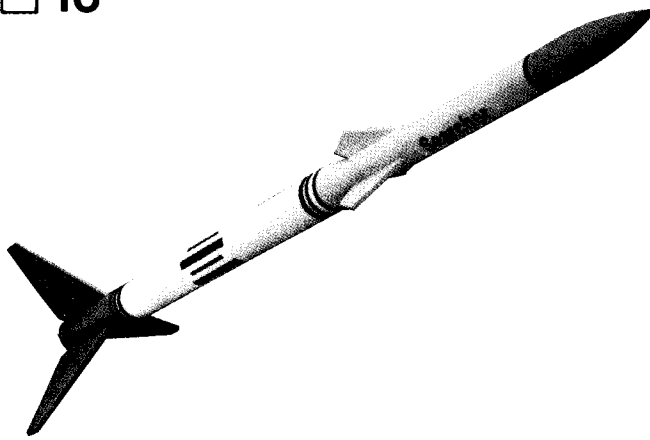

When all paint is dry, apply the decals (part R) in the positions shown. (A) Cut only one decal at a time from sheet. (B) Submerge decal in lukewarm water until decal slides on backing paper (usually 15 to 30 seconds). (C) Gently slide decal from backing paper onto model. (D) Move decal into exact position and carefully blot away excess water with a soft cloth. (E) If the decal "sticks" before you have it in position, apply water over the decal with a brush. This will permit the decal to be moved. (F) Smooth out all wrinkles and air bubbles before the decal dries. We recommend that the completed model be sprayed with Tes-tor's "Gloss-Cote". This is a clear gloss spray paint that protects the model's finish.

LAUNCHING COMPONENTS

- To launch your rocket you will need the following items:
- An Estes model rocket launching system
 - Flame resistant recovery wadding (Estes Cat. No. 2274)
 - Estes A8-5, B4-4, B4-6, B6-4, B6-6, B8-5, C6-5, and C6-7 model rocket engines.
- Use an A8-5 engine for your first flight.

IMPORTANT:

Be sure to follow the HIAA-NAR* Model Rocket Safety Code when carrying out your model rocket activities.
 *HIAA—Hobby Industry Association of America
 *NAR—National Association of Rocketry

COUNTDOWN CHECKLIST

T-13

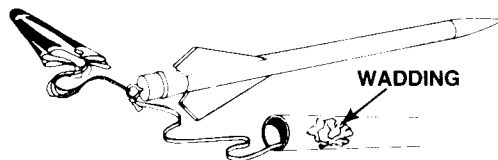

Slide 4 or 5 squares of loosely crumpled recovery wadding into the body tube.

T-12

PULL CHUTE TIGHT

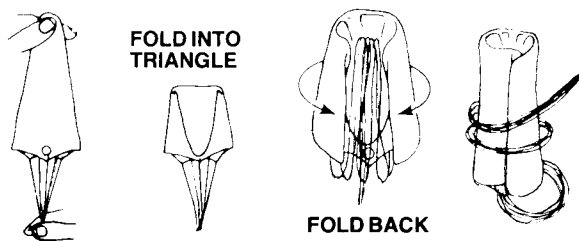

Gather the parachute as shown then fold into a triangular shape. Fold again and insert into rocket body. Slide upper section into place. Align upper and lower fins.

NOTE: DO NOT pack parachute until you are actually ready to launch. For maximum parachute reliability, lightly dust the 'chute with ordinary talcum powder before each flight, especially in cold weather.

NOTE: Adapter section should separate easily from rocket body tube, but should not be extremely loose. If fit is too tight sand inside of body tube and shoulder of adapter with fine sandpaper. If fit is too loose, add a wrapping of transparent tape or masking tape to the shoulder of the adapter.

T-11

INSERT IGNITER

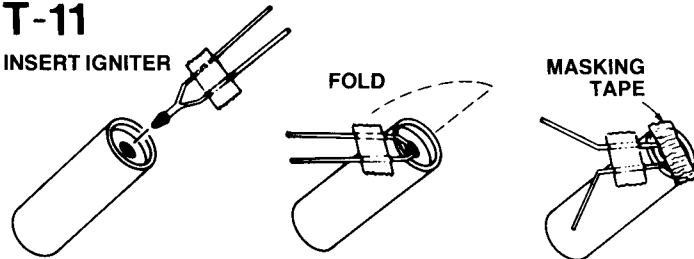

Select an engine and install an igniter as directed in the engine instructions. Use an A8-5 for first flight.

T-10

MASKING TAPE

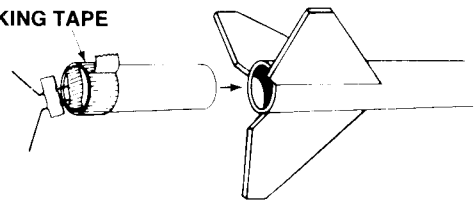

Wrap the rear of the engine with enough masking tape so that it makes a tight fit in the body tube. This fit must be tight to obtain proper parachute deployment. Insert the engine into the rocket so the rear of the engine projects 1/4" from the rear of the body tube.

T-9

Disarm the launch panel—REMOVE SAFETY KEY!

T-8

LAUNCH ROD
 LAUNCH LUG
 MASKING TAPE
 STANDOFF

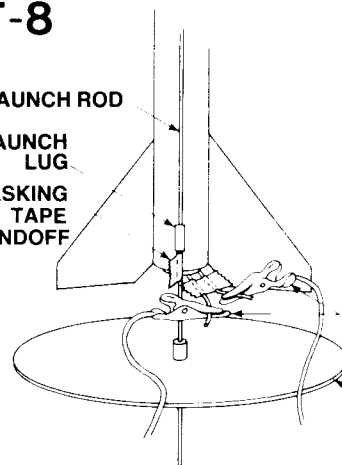

Slide the launch rod through rocket launch lugs and place rocket on launch pad. Make sure the rocket slides freely on the launch rod. Clean the micro-clips and attach them to the igniter wires. Arrange the clips so they do not touch each other or the metal blast deflector. Attach clips as close to protective tape on igniter as possible.

MICRO CLIPS

BLAST DEFLECTOR

T-7

Clear the launch area. Alert recovery crew and trackers. Check for low flying aircraft and unauthorized persons in the recovery area.

T-6

Arm the launch panel—INSERT SAFETY KEY!

5-4-3-2-1-LAUNCH!!

Repeat Countdown Checklist for each flight.

MISFIRE PROCEDURE

Disarm the launch panel. Wait one minute before approaching the rocket on the launch pad. Remove the rocket, clean the igniter residue from the nozzle of the engine, and carefully install a new igniter. Repeat the Countdown Checklist.

Failure of the rocket engine to function properly is nearly always caused by a failure to install the igniter correctly. This failure permits the igniter to heat and burn into two pieces without igniting the engine.

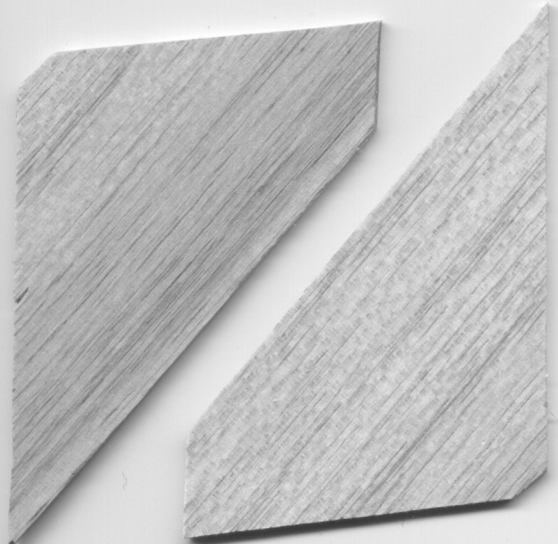

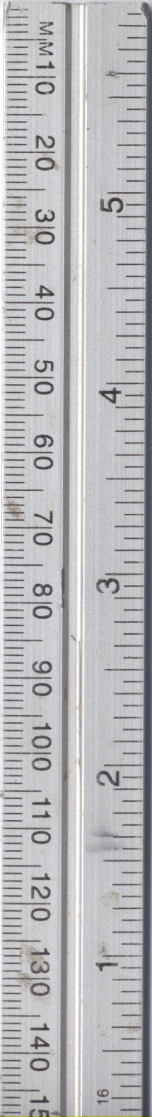

Searcher

ESTES INDUSTRIES PN 37262

Searcher

FLYING MODEL ROCKET

SKILL LEVEL 2

1-Beginner 2-Intermediate 3-Craftman
4-Advanced 5-Expert

- 12" Parachute
- Almost Two Feet Tall
- Sounding Rocket Design

**FLIGHTS
UP TO
1,000 FEET!**

Length: 21.25 in. (53.98 cm)

Dia: .736 in. (18.7 mm)

Weight: 7 oz. (20.02 g)

Engine Types: A8-5 (First Flight),
B4-4, B4-6, B6-4, B6-6, B8-5,
C6-5, C6-7



A DAWSON COMPANY

ESTES INDUSTRIES
PENROBE, CO 81240 USA

Recommended for ages 10 to adult.
Adult supervision suggested for those
under 12 years of age when flying model
rockets. This is a hobby kit requiring as-
sembly. Engines, launch systems, glue
and finishing supplies are not included.

#1945

