





Solar Sailer II™

ESTES INDUSTRIES
1295 H STREET
PENROSE, CO 81240

FLYING MODEL ROCKET KIT NO. 2044

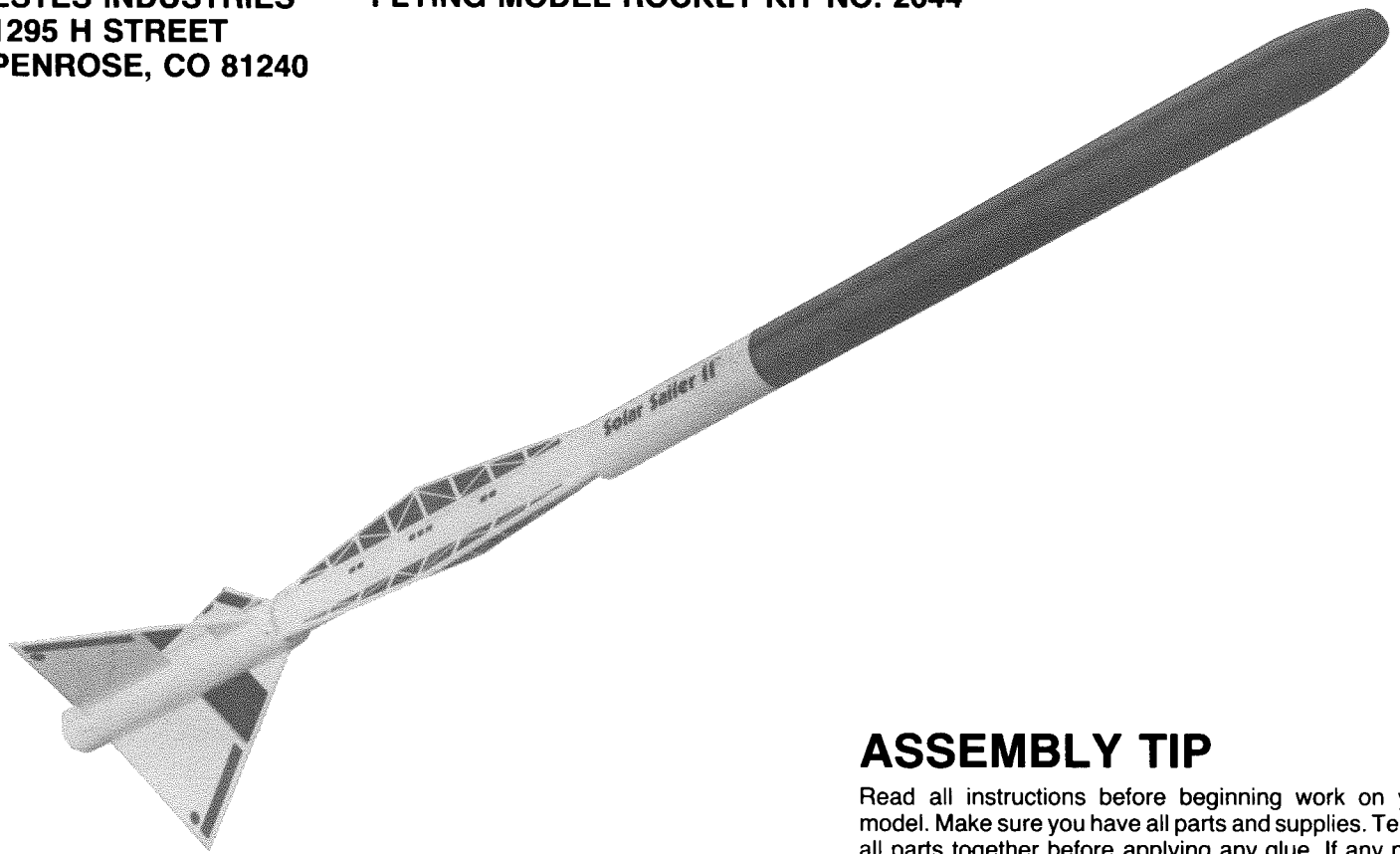

ASSEMBLY TIP

Read all instructions before beginning work on your model. Make sure you have all parts and supplies. Test-fit all parts together before applying any glue. If any parts don't fit properly, sand as required for precision assembly.

PARTS AND SUPPLIES

Locate the parts shown below and lay them out on the table in front of you.

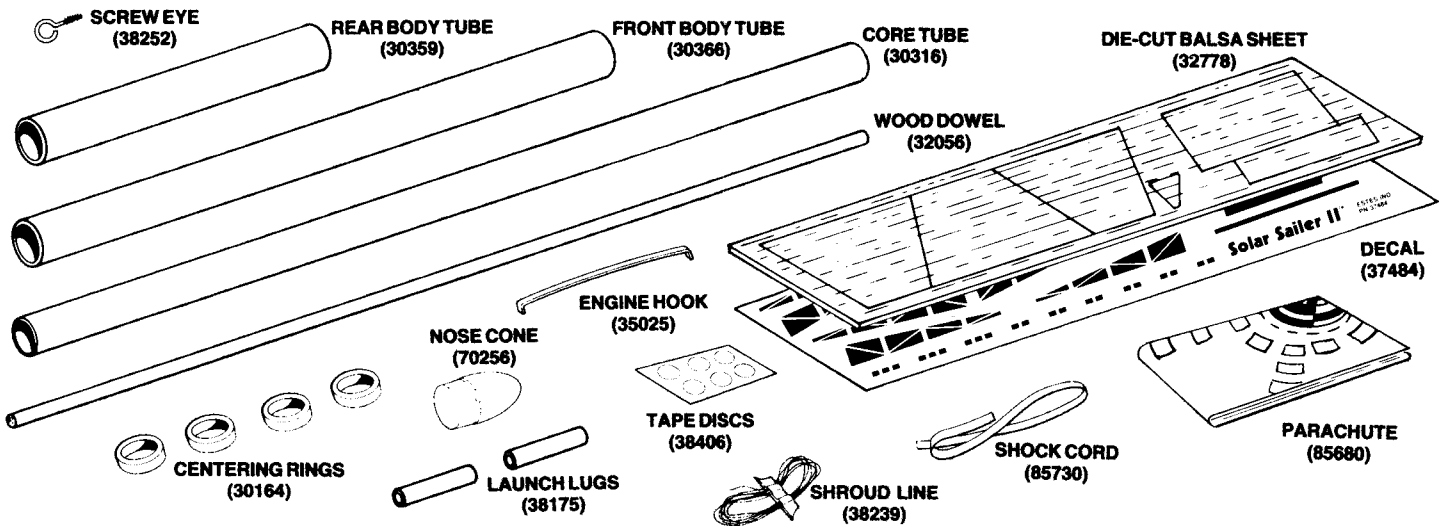

In addition to the parts included in the kit, you will need the following:

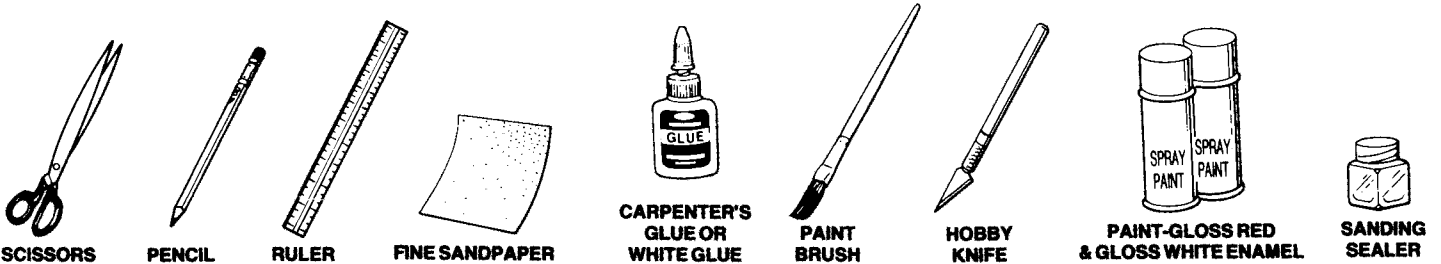

1.

- A. Begin construction with an 18 inch (450 mm) long core tube. Mark a letter 'R' at one end to indicate rear of tube. From this end, mark tube at 1 inch (25 mm), 2½ inches (64 mm), and 6½ inches (165 mm).
- B. Cut BT-20 marking guide from page 5 of the instructions. Wrap guide around middle of tube and tape ends together. Mark tube at each arrow point and remove guide.
- C. Using a door frame as a guide, draw lines on the tube at each mark. Lines should extend from the 6½ inch (165 mm) mark to front of tube.
- D. Cut a 1/8 inch (3 mm) wide slit at the 2½ inch mark (64 mm). Gently bend engine hook so it has a very slight upward bow. Insert one end of engine hook into slit.
- E. Slide a centering ring over front of tube and push down over engine hook. Position rear edge of ring at 1 inch (25 mm) mark and apply glue to both sides of ring-tube joint.
- F. Slide a second ring onto tube and position front edge of ring on 6½ inch (165 mm) mark. Apply a bead of glue around rear of ring-tube joint.

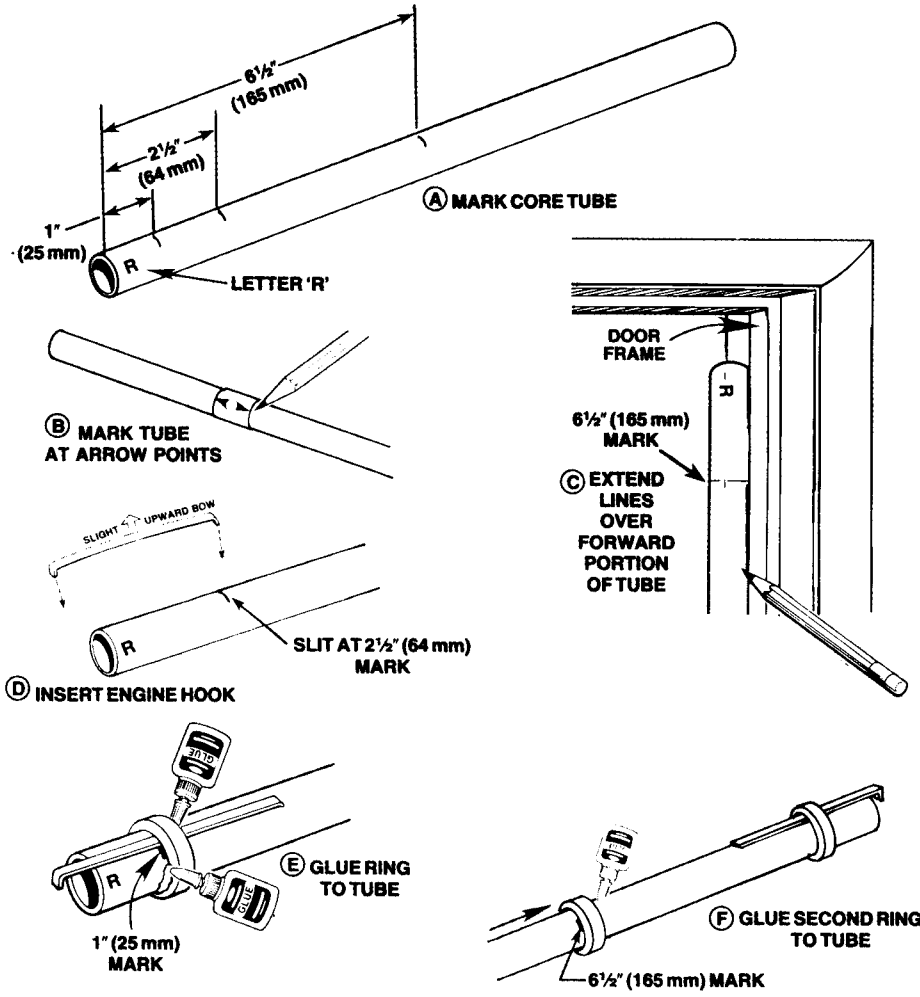

2.

- A. Sand both sides of the balsa sheet with fine sandpaper. Free the die-cut balsa parts with a knife. Stack like parts together and sand edges.
- B. Using a ruler as an edge guide, glue the gusset halves together. NOTE: Before gluing, refer to the template on back of kit panel to make sure parts are correctly oriented.
- C. Cut three pieces of dowel 5¼ inches (133 mm) long. Lay out the fin parts as shown on panel template. The dowel is thicker than the fin material, so a shim must be used when gluing dowel to fin. Lay the other sheet of instructions (folded twice) on a flat surface. Lay a fin on the instruction with the edge that glues to dowel extending off edge of paper. Apply a bead of glue to this edge and attach dowel. Hold parts together until glue sets.
- D. Place a ruler against root edge of fin with end of ruler not quite touching dowel. Place small triangular fin against ruler and check fit of fin against dowel. Sand fin, if necessary, to obtain a good fit. Glue small fin to dowel.
- E. After glue has dried, run a bead of glue along one side of joints between fin pieces and dowel. Wipe joint with your finger to smooth glue and to remove any excess glue. Let this dry, then turn assembly over and apply glue to other side in same manner.
- F. After glue is thoroughly dry, trim dowel to match root edge of fin. Construct two remaining fin assemblies in same manner.

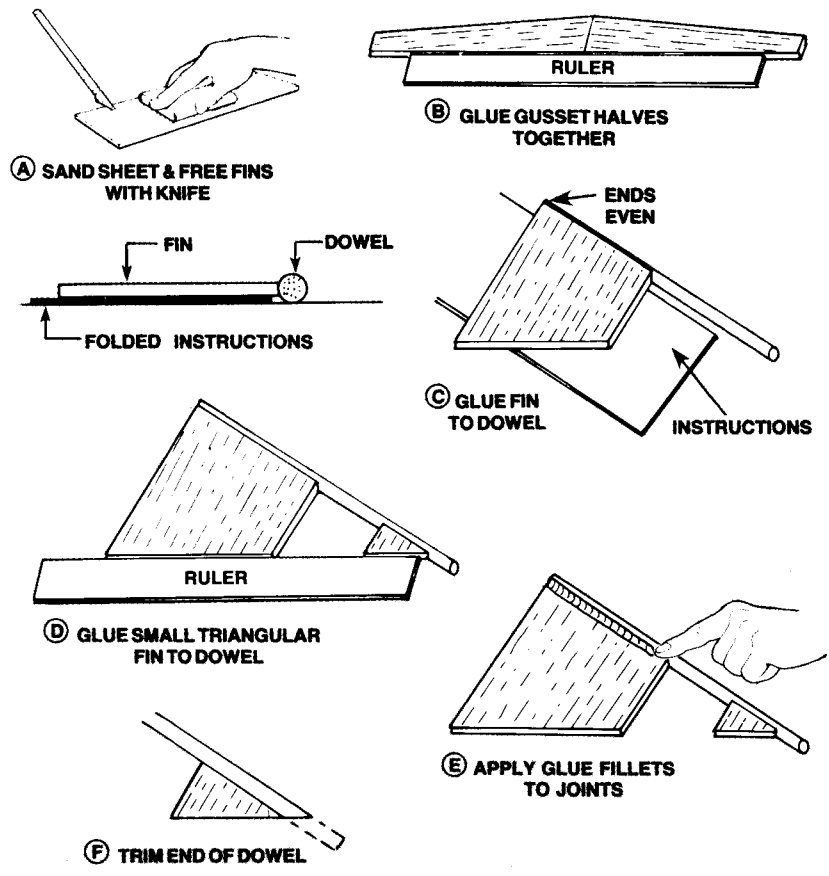

3.

- Slide the 6½ inch (165 mm) long body tube part way over rear of core assembly. Use a toothpick to apply a bead of glue around inside of front of tube. Slide tube forward until front edge of tube is flush with front edge of centering ring.
- Turn assembly over. Use a toothpick to apply a bead of glue around joint between tube and rear centering ring.
- Cut BT-50 marking guide from page 5 of instructions. Wrap guide around rear body and tape ends together. Rotate guide so fin marking points are centered between gusset marking lines (step 1). Mark fin locations, remove guide, and again using door frame as a guide, draw fin lines the length of the rear body tube.

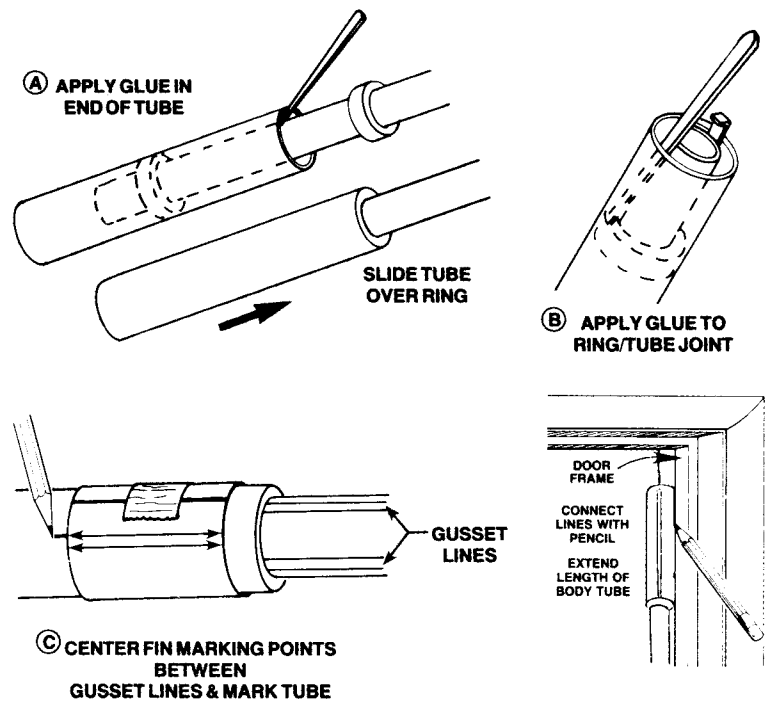

4.

- Apply glue to root edge and one end of a balsa gusset. Glue the gusset to core tube in position shown. Make sure gusset extends straight out from tube. Glue two remaining gussets in place in same manner.
- Place a mark on rear fin lines ¾ inch (19 mm) from rear of body. Glue a fin in place with rear edge on mark. Make sure fin extends straight out from body. Support rocket with fin pointing straight up while glue dries. Attach second fin, let glue dry, then attach third fin.
- For additional strength, the fins must have glue fillets applied. Run a bead of glue along one side of a fin/body joint. Pull your finger along joint to smooth the glue into an even fillet and to remove excess glue. Repeat this step for both sides of all three fins.

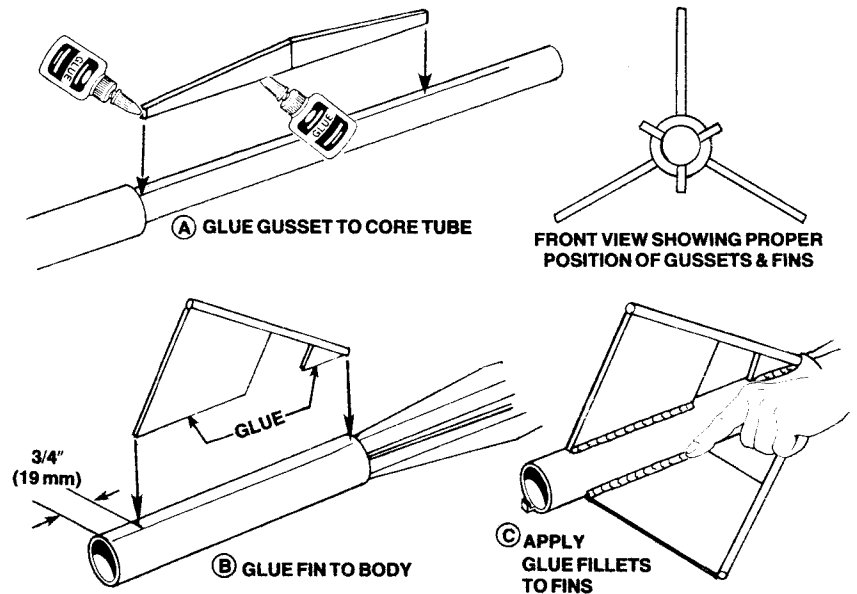

5.

- Slide a centering ring over front of core tube. Apply a bead of glue to the front edge of each gusset. Slide the ring down against the gussets and apply a bead of glue to front of ring/tube joint.
- Slide last centering ring onto end of tube. Position ring about 1/16 inch (2 mm) from end of tube and glue in place.
- After glue has dried, slide remaining body tube over front of core tube and push down almost to second ring. Using a toothpick, apply a bead of glue around inside end of body tube. Push tube down over ring until it butts against gussets.

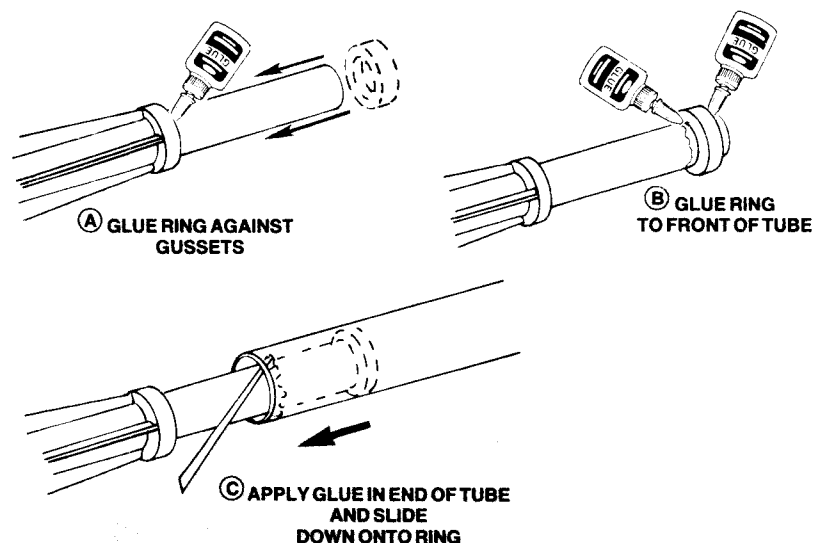

6.

Glue a launch lug to the rear body. The front of the lug should be even with front of rear body tube and the lug should be centered between a gusset and a fin. The second launch lug is glued to rear of front body tube. You must use a rocket launch rod to keep the lugs in proper alignment while glue dries. Apply reinforcing fillets of glue to both sides of both lugs, let glue dry and remove rod.

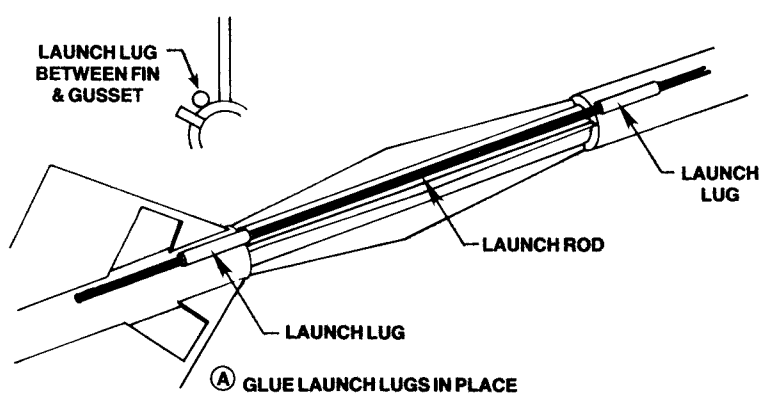
**7.**

- Cut shock cord mount from page 5.
- Crease on dotted lines by folding. Spread glue on section 2 and lay end of shock cord into glue at a slight diagonal as shown. Fold section 1 forward. Apply glue to section 3. Fold forward again. Clamp firmly with your fingers until glue sets.
- Apply glue to the shock cord mount. With the shock cord mount positioned on the end of your finger or a pencil, gently position the mount into the front of body tube. Set back far enough from the front edge of the tube to allow the nose cone to fit into place (1 inch - 25 mm). Press shock cord mount into position. Smear a film of glue over the mount and surrounding area in the body tube to insure a good bond and a smooth surface.

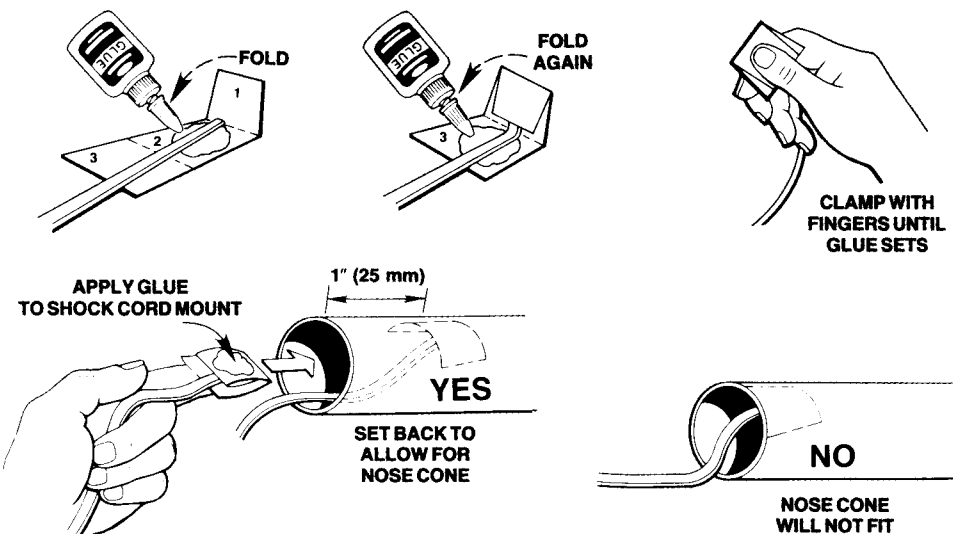
**8.**

- Cut out parachute on edge lines.
- Cut three 35 inch (889 mm) lengths of shroud line.
- Form small loops with ends of shroud line and press onto sticky side of tape discs. Attach tape discs with line ends to top of parachute as shown. Press tape discs firmly into place until tape discs and parachute material are molded around shroud line loops.
- Thread screw eye into base of nose cone. Remove screw eye, squirt glue into hole and replace screw eye.
- Pass shroud line loops through screw eye on nose cone. Pass parachute through loop ends and pull lines tight against the nose cone.
- Tie free end of shock cord to nose cone screw eye. Roll parachute, insert 'chute and shock cord into body and socket nose cone into place.

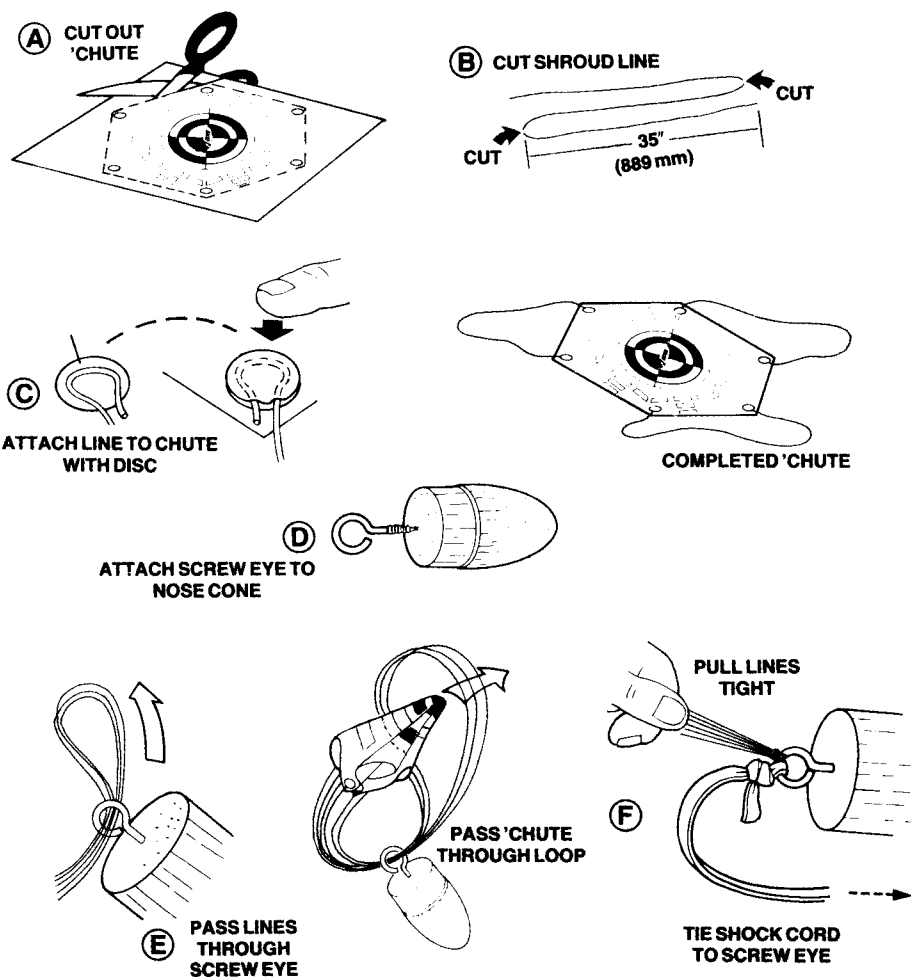

9.

- A. Apply sanding sealer to all balsa surfaces. Let sealer dry then lightly sand. Repeat sealing and sanding until balsa is smooth and grain lines are filled.
- B. Spray the model with gloss white spray enamel. Spray a light first coat and let dry. The second coat should be heavier with a "wet" look, but be careful paint does not run. Let dry overnight.
- C. Wrap a piece of masking tape around forward body at point indicated. Use paper and tape to mask the lower portion of model. Spray the front section bright red.
- D. After paint has dried, apply decals using panel photo as a guide. To apply, cut a decal from sheet, dip in water until decal slides on backing (15 to 30 seconds) and move decal from backing sheet onto model. Move decal into position and gently blot away water with a soft cloth. Note that the gusset decals fit one half of a gusset. There are six left and six right decals. Check location before applying so you don't get any decals upside down. Gusset decals should also be trimmed close to the black ribbed area, so they will fit with no clear material extending beyond gussets.

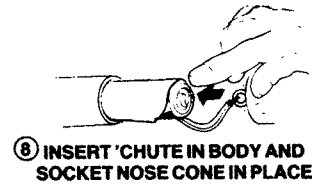
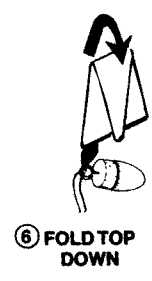
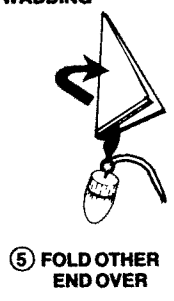
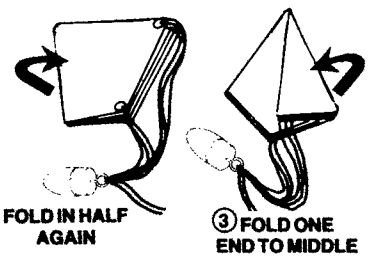
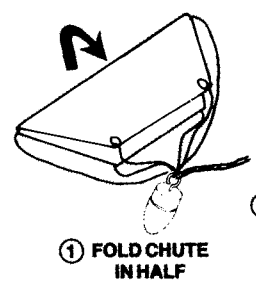
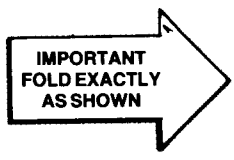
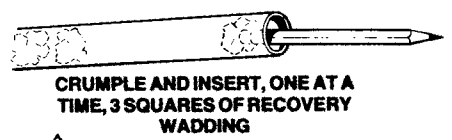
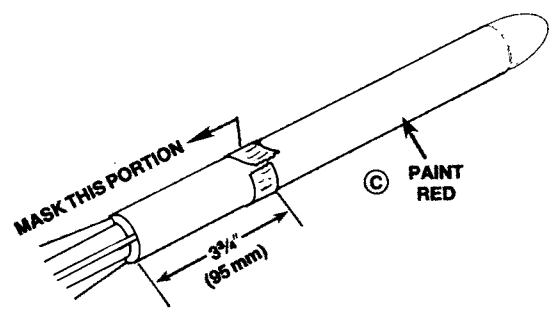
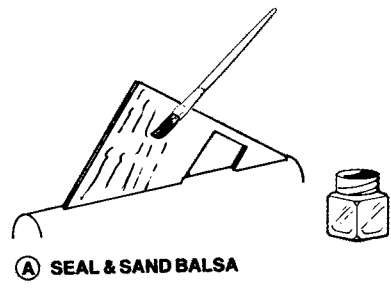

PREPARE ENGINE

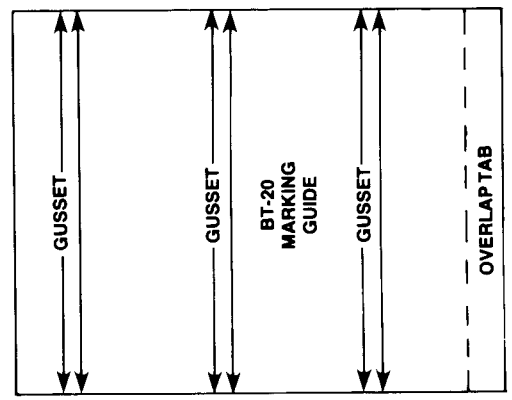
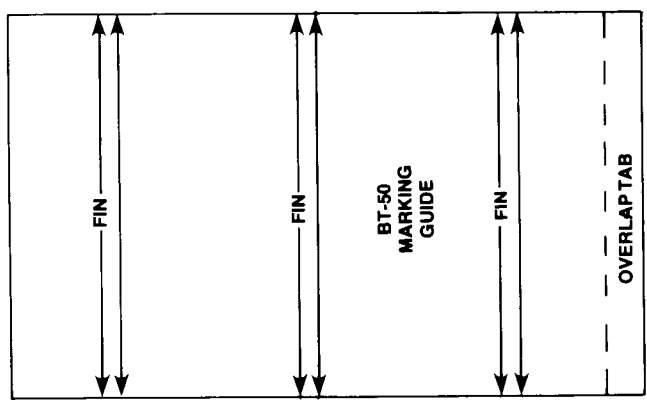
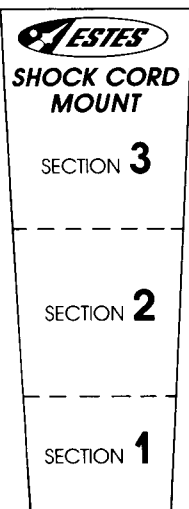
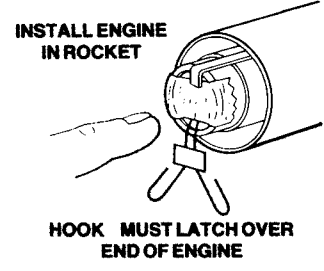
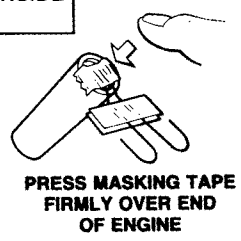
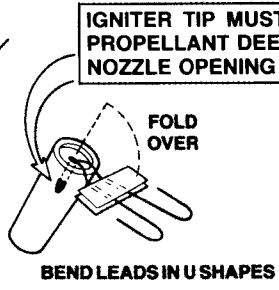
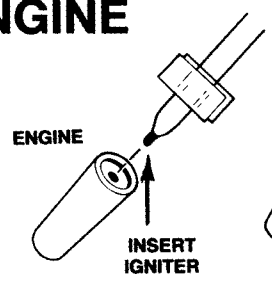
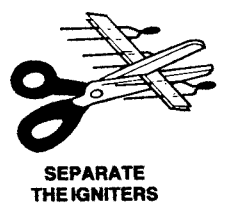

LAUNCH SUPPLIES

To launch your rocket you will need the following items:

- Estes Electrical Launch System
 - Estes Recovery Wadding No. 2274
 - Recommended Estes Engines: A8-3, B4-4, B6-4, B8-5 or C6-5.
- To become familiar with your rocket's flight pattern, use an A8-3 engine for your first flight.

Use only Estes products to launch this rocket.

FLYING YOUR ROCKET

Choose a large field away from power lines, tall trees, and low flying aircraft. Try to find a field at least 250 feet (76 meters) square. The larger the launch area, the better your chance of recovering your rocket. Football fields and playgrounds are great.

Launch area must be free of dry weeds and brown grass.

Launch only during calm weather with little or no wind and good visibility.

Don't leave parachute packed more than a minute or so before launch during cold weather [colder than 40° Fahrenheit (4° Celsius)].

Parachute may be dusted with talcum powder to avoid sticking.

MISFIRES

Failure of the model rocket engine to ignite is nearly always caused by incorrect igniter installation. An Estes igniter will function properly even if the coated tip is chipped. However, if the coated tip is not in direct contact with the engine propellant, it will only heat and not ignite the engine.

When an ignition failure occurs, remove the safety key from the launch control system and wait one minute before approaching the rocket. Remove the expended igniter from the engine and install a new one. Be certain the coated tip is in direct contact with the engine propellant, then tape the igniter leads firmly to base of engine as illustrated above. Repeat the countdown and launch procedure.

FOR YOUR SAFETY AND ENJOYMENT

Always follow the NAR-HIA* MODEL ROCKETRY SAFETY CODE while participating in any model rocketry activities.

*National Association of Rocketry-The Hobby Industry of America

COUNTDOWN AND LAUNCH

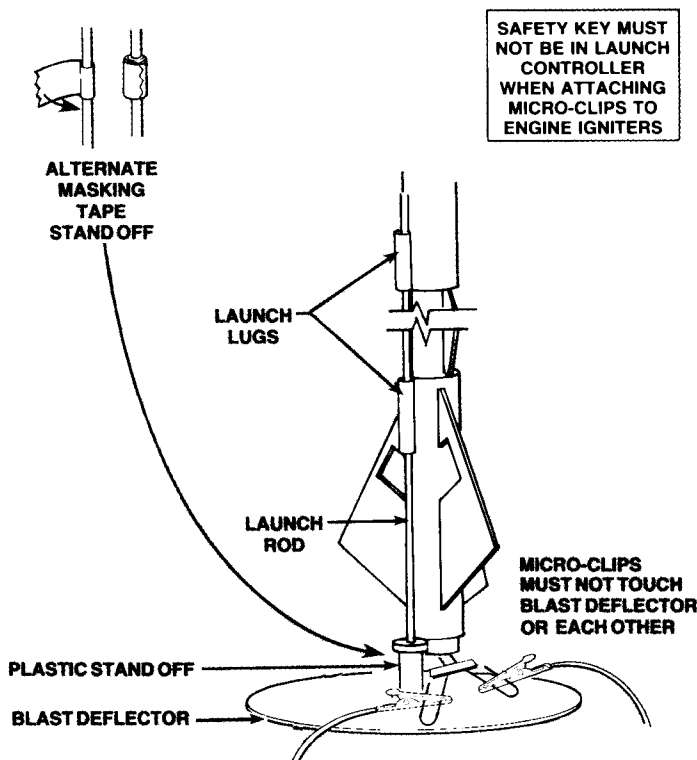

- ⑩ BE CERTAIN SAFETY KEY IS NOT IN LAUNCH CONTROLLER.
- ⑨ Remove safety cap and slide launch lug over launch rod to place rocket on launch pad. Make sure the rocket slides freely on the launch rod.
- ⑧ Attach micro-clips to the igniter wires. Arrange the clips so they do not touch each other or the metal blast deflector. Attach clips as close to protective tape on igniter as possible.
- ⑦ Move back from your rocket as far as launch wire will permit (at least 15 feet - 5 meters).
- ⑥ INSERT SAFETY KEY to arm the launch controller.

Give audible countdown 5...4...3...2...1

LAUNCH!! PUSH AND HOLD LAUNCH BUTTON UNTIL ENGINE IGNITES

Remove safety key—Replace cap on launch rod.



ROOT EDGE -- THIS EDGE GLUES TO BODY

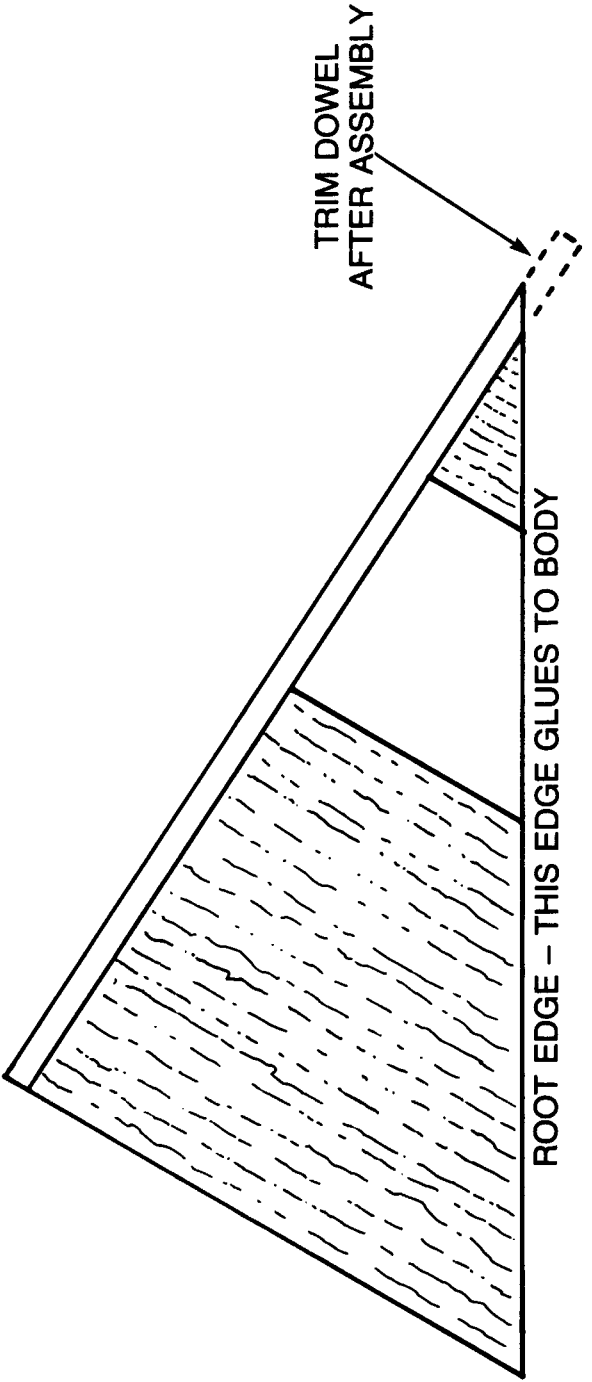

TRIM DOWEL
AFTER ASSEMBLY

ROOT EDGE -- THIS EDGE GLUES TO BODY

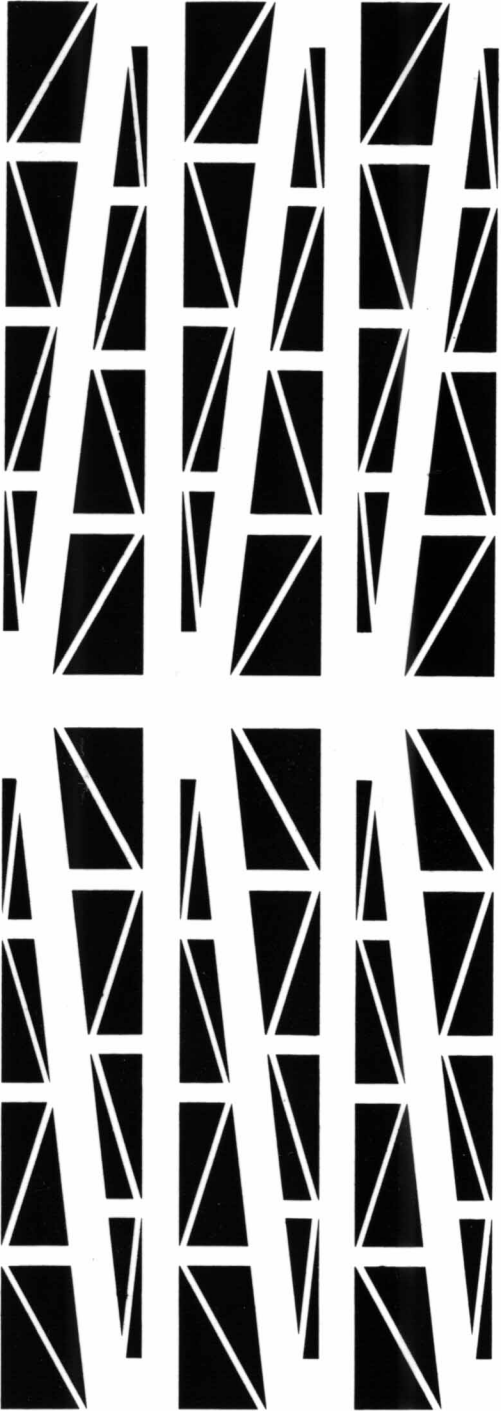

Solar Sailer II™

ESTES IND.
PN 37484

solar sailer II™



11511
11512
11513
11514
11515
11516
11517
11518
11519
11520
11521
11522
11523
11524
11525
11526
11527
11528
11529
11530
11531
11532
11533
11534
11535
11536
11537
11538
11539
11540
11541
11542
11543
11544
11545
11546
11547
11548
11549
11550
11551
11552
11553
11554
11555
11556
11557
11558
11559
11560
11561
11562
11563
11564
11565
11566
11567
11568
11569
11570
11571
11572
11573
11574
11575
11576
11577
11578
11579
11580
11581
11582
11583
11584
11585
11586
11587
11588
11589
11590
11591
11592
11593
11594
11595
11596
11597
11598
11599
11600

