

MODEL ROCKET NEWS

Vol. 13, No. 3
Sept./Oct. 1973

Featured In This Issue:

- Rocketoon Contest Winners . . . Page 1
- Notes From Vern
(Foreign Model Rocketry) . . . Page 2
- Idea Box Page 3
- Model Rocket Brain Buster . . . Page 3
- EQUINOX Free Plan Pages 4-5
- Recovery Article, Part II . . . Pages 6-7
- DOM Contest Winners Page 8

ROCKETOON CONTEST WINNERS

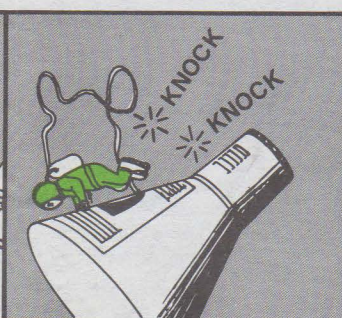
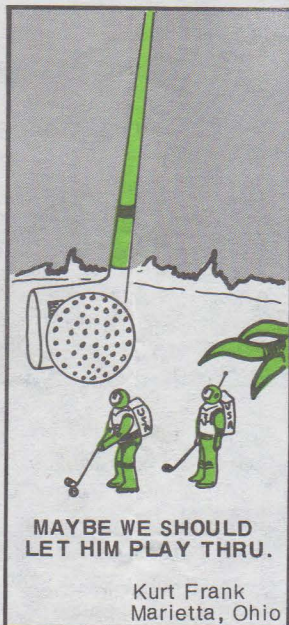

IMPORTANT: Due to space requirements, a listing of all Rocketoon "Goonybird" Contest winners is not possible in this issue. All winners have been contacted by mail. A listing of all winners is available from Estes Industries, Rocketeer Communications Department.

NOTES FROM VERN



As you are reading this issue of Model Rocket News the astronauts of Skylab II should be on the last leg of their journey, and most of you will be starting another interesting school year. We at Estes hope you have had a most enjoyable summer and wish you the very best of success in your academic activities.

A number of you have written asking about model rocketry activities in other countries. Even though model rocketry originated in the United States, it's excitement has spread rapidly throughout the world and is now enjoyed as a favorite hobby in more than 50 countries. I would like to take this opportunity to share with you some interesting photos given to me by an old friend, Ottar Siffek, of Czechoslovakia when we met at the first World Championships at Vrsac, Yugoslavia in September 1972 (MRN Vol. 12 No. 4). You will notice that like American rocketeers, the Europeans also have varied interests in the types of models they like to build.

projects for rocketeers the world over. These photos show East European versions which utilize straight or canted engine clusters (this type of project is for advanced rocketeers only and care must be used in both vehicle design and selection of a suitable launch site).

Crazy configurations and funny models are also popular in other countries. These weirdo designs prove that a model rocket does not have to look like a rocket to fly like one.



hobby can become a common bond for bringing more people from around the world closer together. I sincerely hope so!

Vern

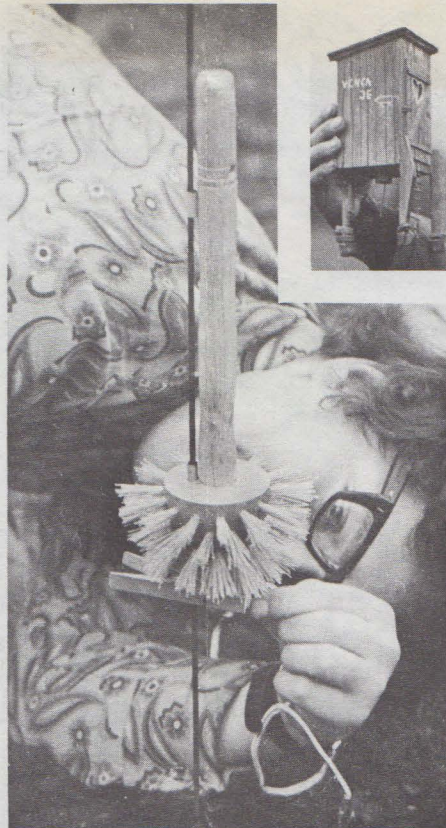

NARAM-15



NEXT ISSUE "NARAM-15"

Featuring photos, information, and highlights of the 15th Annual National Model Rocketry Championships. **DON'T MISS IT!!**

MODEL ROCKET NEWS

● ESTES INDUSTRIES 1973

The MODEL ROCKET NEWS is published by Estes Industries, Inc., Penrose, Colorado. This publication is written for America's model rocketeers to promote safe youth rocketry, distribute current technical information, and make model rocketry more enjoyable and educational. Current issues of the MRN are distributed free of charge to all active Estes customers.

Vern Estes Publisher
Dane Boles Editor
Bob Cannon Dir. of Publications
Charles Webb Photographer



A SUBSIDIARY OF DAMON

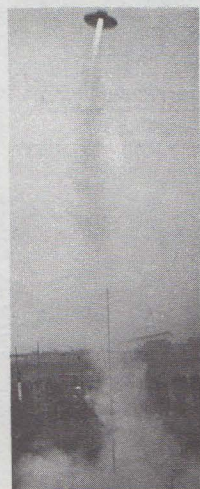
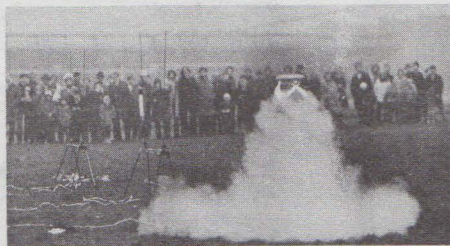

Flying saucers have become one of the most challenging types of R & D

Scale models held the greatest popularity and interest at Vrsac, as they do at most meets. Completely scratch-built scale replicas of vehicles from both the U.S. and Russian space programs were the featured entries. In the photo (upper right) a Bulgarian contestant (at an earlier meet) prepares to launch a scratch-built Mercury Redstone.

As you can see, model rocketry in other countries is not too much different from model rocketry in our own country. Regardless whether you're a Russian, Czechoslovak, Rumanian, Egyptian, Yugoslav, British, Canadian, Polish, Bulgarian, or United States rocketeer, model rocketry means people getting together and having fun. Perhaps our

Brain Buster Contest

Win an Interceptor

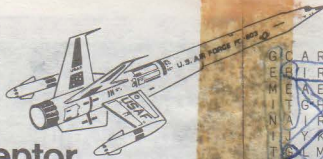

Directions: The names of more than 50 Estes models can be found among these letters. The names sometimes read forward, other times backward, up, down, or even diagonally. Circle each name as you discover those listed below. Then guess the total number of additional names left in the Brain Buster which are not listed below. Hint: There are at least a dozen left.

The first correct answer from each state will receive a free Interceptor kit, featuring exotic deep space styling.

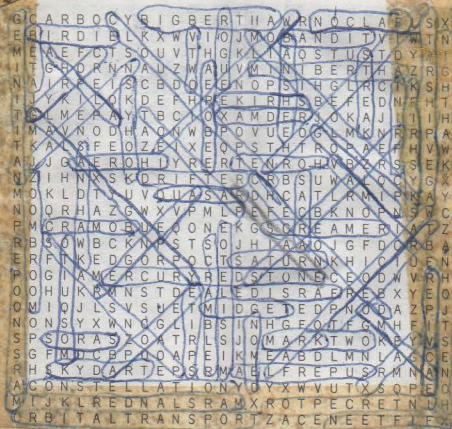

- SAND HAWK
- AERO-HI
- BANSHEE
- BIG BERTHA
- EAC VIPER
- GALAXY GUPPY
- HORNET
- JAVELIN
- MERCURY REDSTONE
- SKY SHRIEK
- WAC CORPORAL
- ZOOM BROOM
- AEROBEE
- ARCAS
- CONSTELLATION
- DRIFTER

- LITTLE JOHN
- MARK TWO
- MINI-BERTHA
- MOSQUITO
- ROGUE
- SCREAMER
- SKY HOOK
- STAR SNOOP
- SUPER FLEA
- X-FIFTEEN
- X-RAY
- AVENGER
- CHEROKEE D
- CLOUD HOPPER
- MIDGET
- MISSILE TOE
- RED MAX
- FARSIDE
- MINI-BOMARC
- OMEGA
- SCRAMBLER
- SHRIKE
- SPRITE
- STAR BLAZER
- STARSHIP VEGA
- V-TWO
- WOLVERINE
- GEMINI-TITAN
- HONEST JOHN
- MARS SNOOPER
- NIGHT HAWK
- ORBITAL TRANSPORT
- SKY DART
- MARS LANDER

Send your entries to "Brain Buster," Estes Industries, Penrose, Colorado 81240. Remember to include your name, address, and your guess. Maybe you will be the proud owner of an Interceptor. Hurry! Enter today!!

Brain Buster by Richard Kamienski, Canastota, N.Y.

streak
birdie
bandit
quasar
bomark
saturn
Interceptor
Beta
Searall
Sprint
Kiper
Gypoc
Trident
Patriot
Vampire
Alpha
Demor
Goblin
Falco
Apogee
Saro

THE IDEA BOX

TANGLE FREE SHROUD LINES

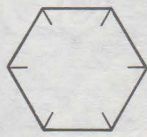

Draw and cut out a hexagon from firm paper. Cut slits at each corner and insert a shroud line at each slit. Seal each slit with glue to prevent shroud lines from catching at corners.

David Pedersen
Valley Stream, New York

DISPLAY & PAINT STAND

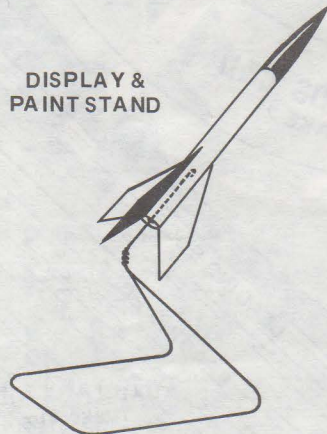

An easy and inexpensive way to display or paint your models can be made using an old coathanger bent into the shape shown in illustration.

Martin Knobel
Homer, New York

FIN RIVETS

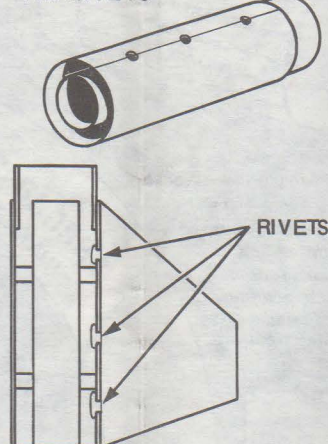

Mark the fin guide lines on the body tube in the usual manner. Then using a small drill bit 1/16" smaller than thickness of balsa drill three holes in the body tube along the line where fin will set. Apply a line of glue to the line on body tube and push glue thru the holes, then set fin on glue line. When dry, the glue will have created fin rivets for greater strength.

Glade Gordon
Vice President
Skywatchers Rocket Club
Colorado Springs, Colorado

FIN COVERS



Fin covers protect fins while painting, they can easily be made out of construction paper and tape.

John Reyes
New York, New York

MRN CONTRIBUTIONS WANTED

Got any good ideas for MODEL ROCKET NEWS articles, technical information, cartoons, anecdotes, club news of unusual interest, etc.? Then why not submit them to us for possible publication? Our constant aim is to make MRN a better, more interesting magazine, and you might just be the type of contributor we need.

If you send us photos, please make sure that you pack them between cardboard sheets so that they won't get creased in the mail. Also tell us in your letter if you want your material returned. Address all material to: Editor, MRN, Estes Industries, Penrose, Colo. 81240.

Should your article or photos be used in MRN, we'll reward your efforts and talent with an Estes merchandise certificate, the amount of which will be determined by the MRN editorial staff.

Hope to hear from you soon!

A Rocket for Your Teacher!

Want to do your teacher a real favor? Instead of an apple, give your teacher a rocket! We will be happy to send to your teacher a free Alpha model rocket kit. In fact, we'll also send a free teacher's guide suggesting some really great ways to use model rockets as school projects. Maybe you and your teacher can get a special demonstration launch for your class (or even the whole school!).

Send your teacher's name and school address (include zip code) today to Education Department, Dept. 107, Estes Industries, Penrose, Colorado 81240 and ask that we send Educator Packet EP-2. Be sure to include your own name and address.

Aw 'Chute'

Part II

by Wayne Kellner, Estes R&D Dept.

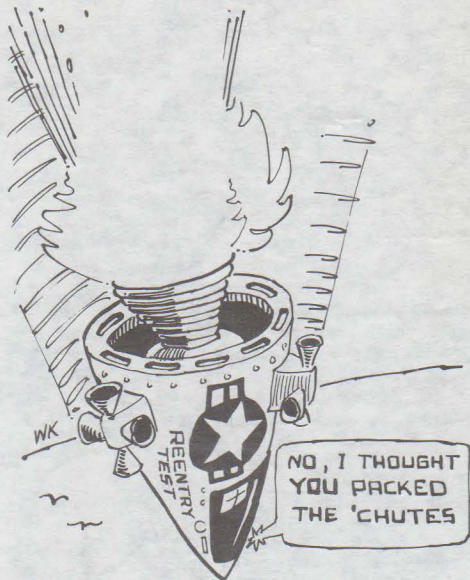

Second installment in a three part technical report on model rocket recovery -- techniques, types, and tips. In this article we pass along a bagful of suggestions and tips on rocket tracking and parachute recovery techniques.

ZAP

Now that I've got your attention, let's look at a few ideas to help you follow a rocket during its flight.

PAINTING

We will consider here primarily sport flying rockets, payload and contest rockets, or any bird where a specific paint scheme is not required.

First, examine your flying field. You will want to select a contrasting paint color which will make your rocket stand out from the recovery area background. Is the launch and recovery area rather dark in color -- trees, bushes, green grass, etc? If so, paint the rocket a bright contrasting color such as white, yellow, or orange. When flying against a light background color, use a dark contrasting paint. Bright red, orange, perhaps even blue or black will show up well.

Obviously, for winter launching, a white rocket would be somewhat difficult to locate in the snow. Or, for our Amazon friends, I wouldn't recommend flying green rockets. A bright red-orange fluorescent paint is best for most flying conditions. This color is easy to follow during flight and especially easy to spot on the ground. For brightest and best results, always apply a fluorescent color over a white undercoat. Fluorescent paints are slightly transparent by themselves and will allow wood grain or any dark base surface to show through.

FIGURE 1

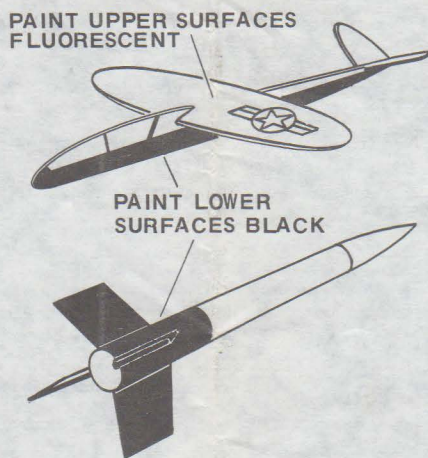

Black, believe it or not, is the easiest color to follow during flight. Although it may not always be easy to spot on the ground, you might try the following idea. For gliders, paint all bottom surfaces black in order to help you follow it during flight. See Figure 1. Then paint all upper surfaces fluorescent orange so that you have a bright color to help locate the glider on the ground. For rockets, paint the lower 1/3 black, then paint the remainder of the rocket a fluorescent color. Why not experiment to determine which colors are best for your flying area?

A quick note here about weight. Paint adds weight to any bird, much more than you would imagine. The darker the color is, the more color pigment it has. Therefore, the darker the color the heavier the paint. If you are building a model which you wish to keep ultra-lightweight, finish it with white, yellow, or orange paint. A very light coat (or "dusting") of paint may be sufficient to color the model.

KEEP ON TRACKIN'

Have you ever tried attaching shiny silver foil to your rocket? During flight, sunlight reflecting from the foil

looks just like a bright blinking light. Especially for those "outsight" D-powered birds, the flashing foil will help you track the rocket clear to touchdown. The Estes D-power Demon uses a special stick-on foil decal on its payload compartment.

FIGURE 2

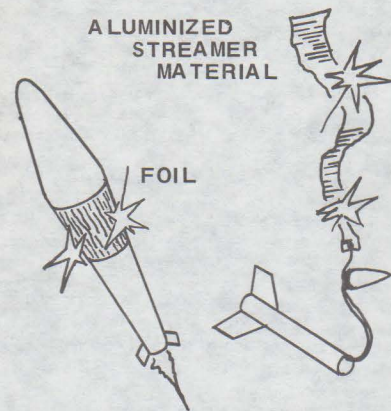

Estes aluminized parachute material (available from catalog) is perfect for custom parachutes and streamers. It's bright reflective surface is also easy to spot in the air and on the ground. Some rocketeers have even attached small foil streamers to the corners of their parachutes for added visibility. Whether you add model aircraft silver Monocote, chrome mylar foil, stick-on silver foil, or ordinary aluminum foil, make a neat job of it. You don't want unnecessary drag or loose corners affecting the rocket's stability. Double-sided sticky tape or contact cement works well for attaching aluminum foil. You might even try building an all-foil-covered research-looking rocket.

FIGURE 3

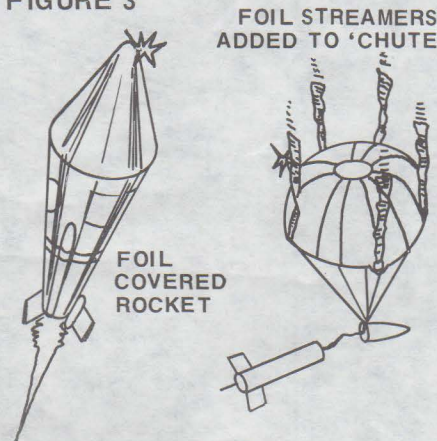

Now, for you "try anything once" rocketeers. Next time you're out at the flying field, put a small amount of

EQUINOX

SKILL LEVEL 2

HONORABLE MENTION
 DESIGN OF THE MONTH
 By MIKE ROSSI Canon City, Colo.
 ESTES INDUSTRIES ROCKET PLAN NO. 80

★ BUILD THE EQUINOX WITH ESTES HIGH PERFORMANCE PARTS AND ACCESSORIES

PARTS LIST

- 1 NOSE CONE - BNC-50J
- 1 BODY TUBE - BT-50
- 1 BODY TUBE - BT-55
- 1 BODY TUBE - BT-20J
- 2 CENTERING RINGS - AR-2050
- 2 CENTERING RINGS - AR-5055
- 1 ENGINE BLOCK - EB-20A
- 2 FIN STOCK - BFS-30
- 1 LAUNCH LUG - LL-2B
- 1 PARACHUTE KIT - PK-18
- 1 SHOCK CORD - SC-2
- 1 SCREW EYE - SE-2
- 1 6" x 6" SMOOTH WHITE PAPER

ADDITIONAL MATERIALS

- Hobby Knife
- White Glue
- Ruler
- Sanding Material
- Sanding Sealer
- Enamel Paint (Spray)
- Sharp Pencil

RECOMMENDED ENGINES

- A8-3 B6-4 C6-5

1

a. Apply glue around the inside of one end of the engine holder tube and insert the engine block until it is flush with the end of the tube.

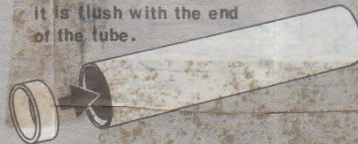

b. Glue a centering ring (AR-2050) to each end of the engine holder tube (BT-20J) and set aside to dry.

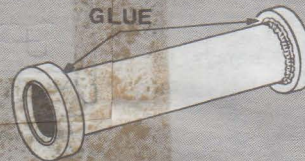

2



Measure 11 5/8" from one end of the body tube and cut tube at this point. Method: Wrap masking tape for raised guide line and cut with sharp hobby knife. Measure the other end of the BT-55 body tube previously.

5

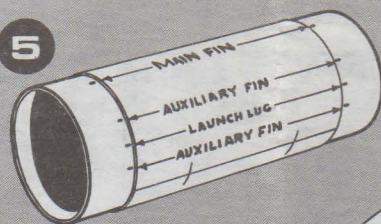

Cut out the fin marking guide and wrap it around the BT-55 body tube, place a mark at each arrow point. Using a pencil, identify each line on the BT-55. Remove marking guide and draw straight lines connecting each matching front and rear mark.

6

Apply glue to each AR-5055 centering ring. Then slide BT-55 body tube onto rings in one smooth motion until ends of BT-55 are flush with centering rings.

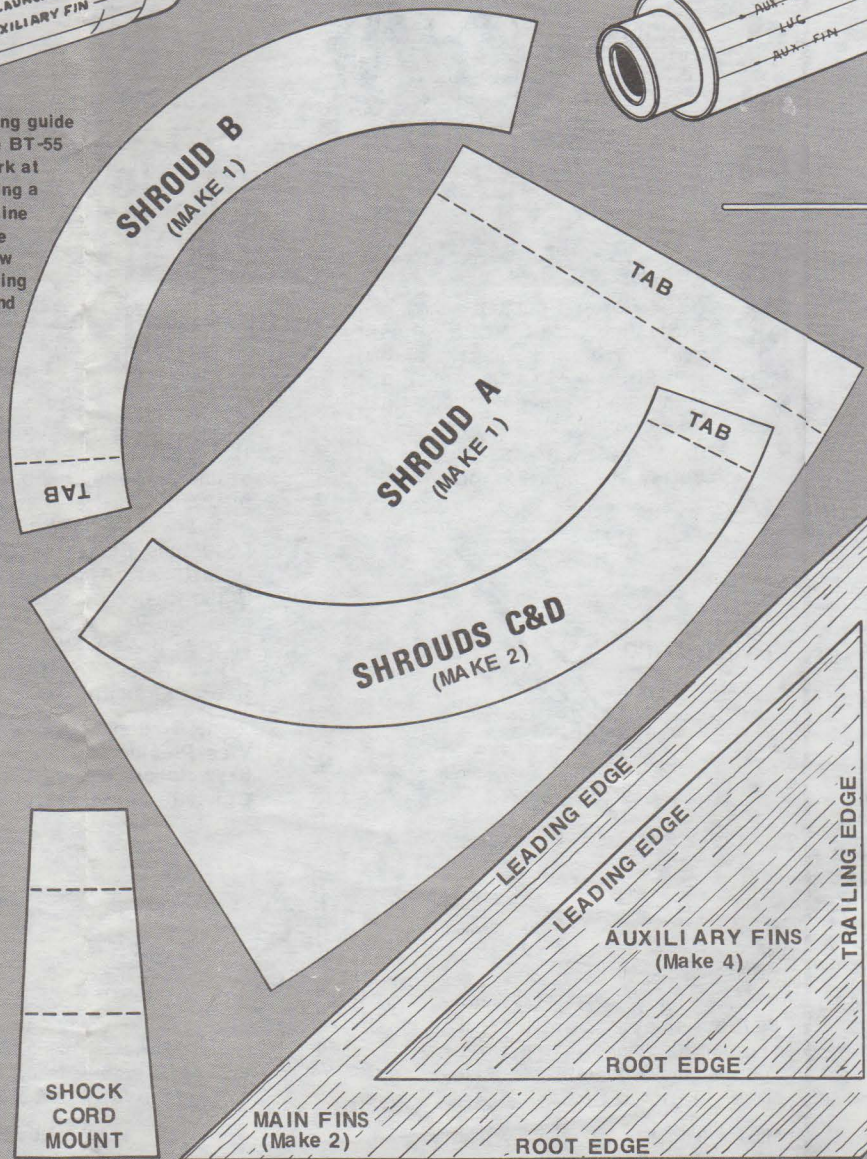
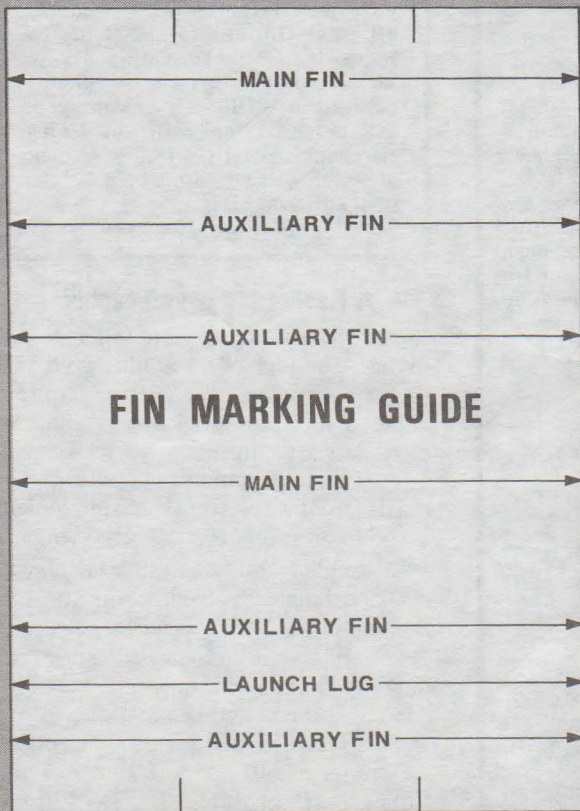
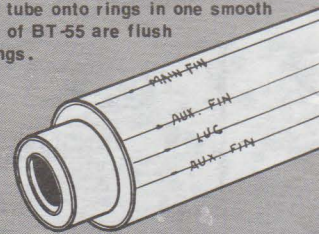

EQUINOX

SKILL LEVEL 2

HONORABLE MENTION
DESIGN OF THE MONTH
By MIKE ROSSI Canon City, Colo.
ESTES INDUSTRIES ROCKET PLAN NO. 80

★ BUILD THE EQUINOX WITH ESTES HIGH PERFORMANCE PARTS AND ACCESSORIES

PARTS LIST

- 1 NOSE CONE - BNC-50J
- 1 BODY TUBE - BT-50
- 1 BODY TUBE - BT-55
- 1 BODY TUBE - BT-20J
- 2 CENTERING RINGS - AR-2050
- 2 CENTERING RINGS - AR-5055
- 1 ENGINE BLOCK - EB-20A
- 2 FIN STOCK - BFS-30
- 1 LAUNCH LUG - LL-2B
- 1 PARACHUTE KIT - PK-18
- 1 SHOCK CORD - SC-2
- 1 SCREW EYE - SE-2
- 1 6"x6" SMOOTH WHITE PAPER

ADDITIONAL MATERIALS

- Hobby Knife
- White Glue
- Ruler
- Sanding Material
- Sanding Sealer
- Enamel Paint (Spray)
- Sharp Pencil

RECOMMENDED ENGINES

- A8-3
- B6-4
- C6-5

1

a. Apply glue around the inside of one end of the engine holder tube and insert the engine block until it is flush with the end of the tube.

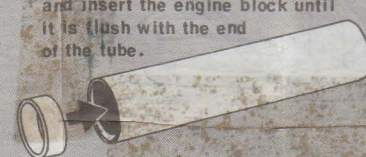

b. Glue a centering ring (AR-2050) to each end of the engine holder tube (BT-20J) and set aside to dry.



2

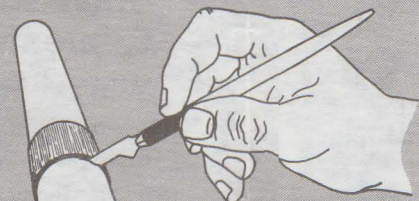

Measure 11 5/8" from one end of the BT-50 body tube and cut tube at mark. (Recommended method: Wrap masking tape around body tube for raised guide line and carefully cut tube with sharp hobby knife.) Measure 3 9/16" from one end of the BT-55 body tube and cut as mentioned previously.

3

Glue the engine mount assembly into one end of the BT-50 tube (Make sure the end containing the engine block enters first.) until it is flush with the BT-50.

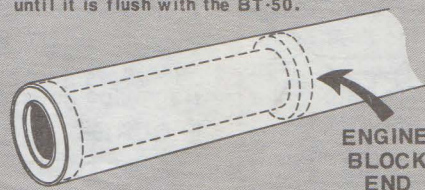

4

Measure and mark the BT-50 body tube 5/8" and 3 15/16" from the end containing the engine mount. Glue the AR-5055 centering rings at these marks as shown.

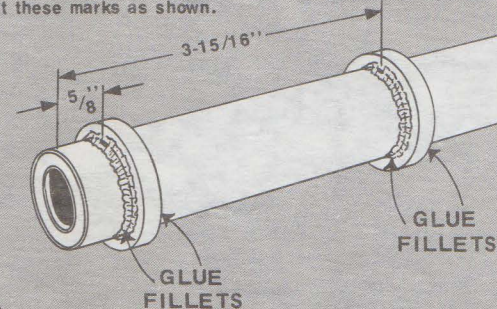

5

Cut out the fin marking guide and wrap it around the BT-55 body tube, place a mark at each arrow point. Using a pencil, identify each line on the BT-55. Remove marking guide and draw straight lines connecting each matching front and rear mark.

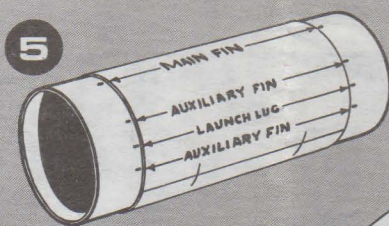

6

Apply glue to each AR-5055 centering ring. Then slide BT-55 body tube onto rings in one smooth motion until ends of BT-55 are flush with centering rings.

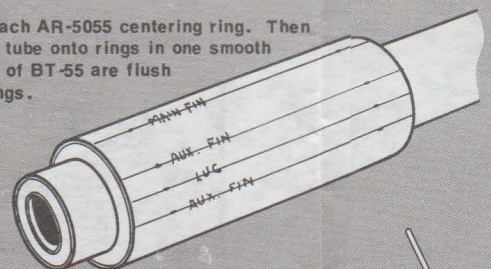

7

a. Cut out fin patterns and trace them onto the fin stocks BFS-30 and carefully cut out each fin.

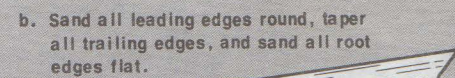

b. Sand all leading edges round, taper all trailing edges, and sand all root edges flat.

c. Apply glue to the root edge of each main fin and glue each one onto the corresponding line drawn on the BT-55 body tube. Make sure each fin is glued straight away from the body tube. (See rear view illustration.) Do the same to all auxiliary fins.

d. Glue the launch lug on the appropriate line so that its end is even with the rear end of BT-55.

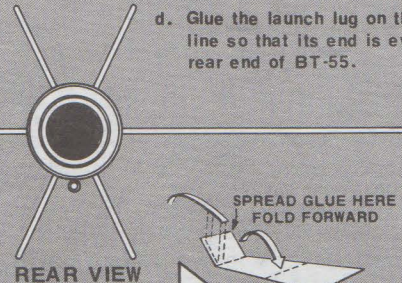

9

a. Assemble parachute according to its instructions.

b. Cut out shock cord mount, assemble, and glue to the inside of the BT-50 about 1 1/4" from the end.

c. Glue the screw eye into the nose cone, and tie the shock cord and parachute shroud lines to the screw eye as shown.



10

FINISHING PROCEDURES:

Apply glue fillets to all fins and set aside to dry. After all glue has dried completely, sand all balsa smooth, then apply sanding sealer. Repeat this procedure until balsa is smooth. Refer to color scheme photo for painting ideas.

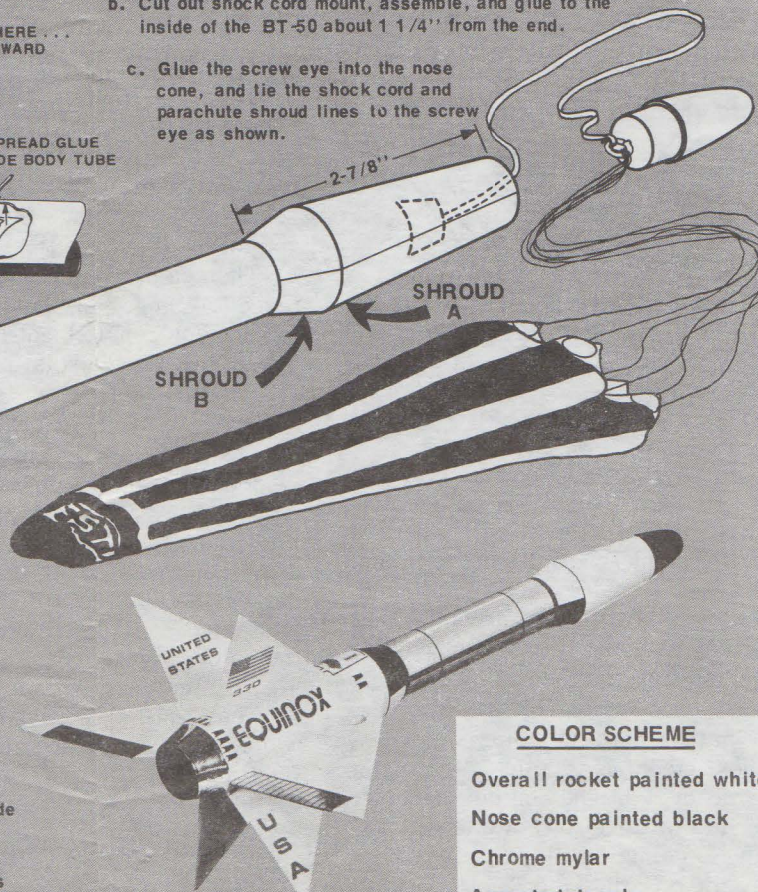

COLOR SCHEME

- Overall rocket painted white
- Nose cone painted black
- Chrome mylar
- Assorted decals

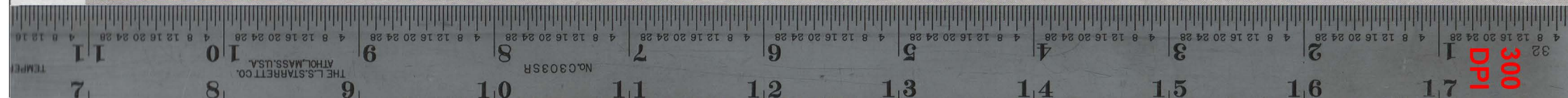
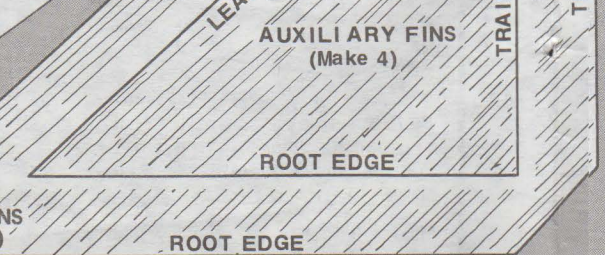
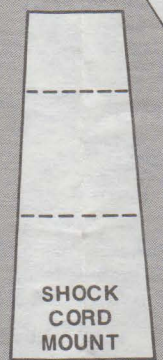
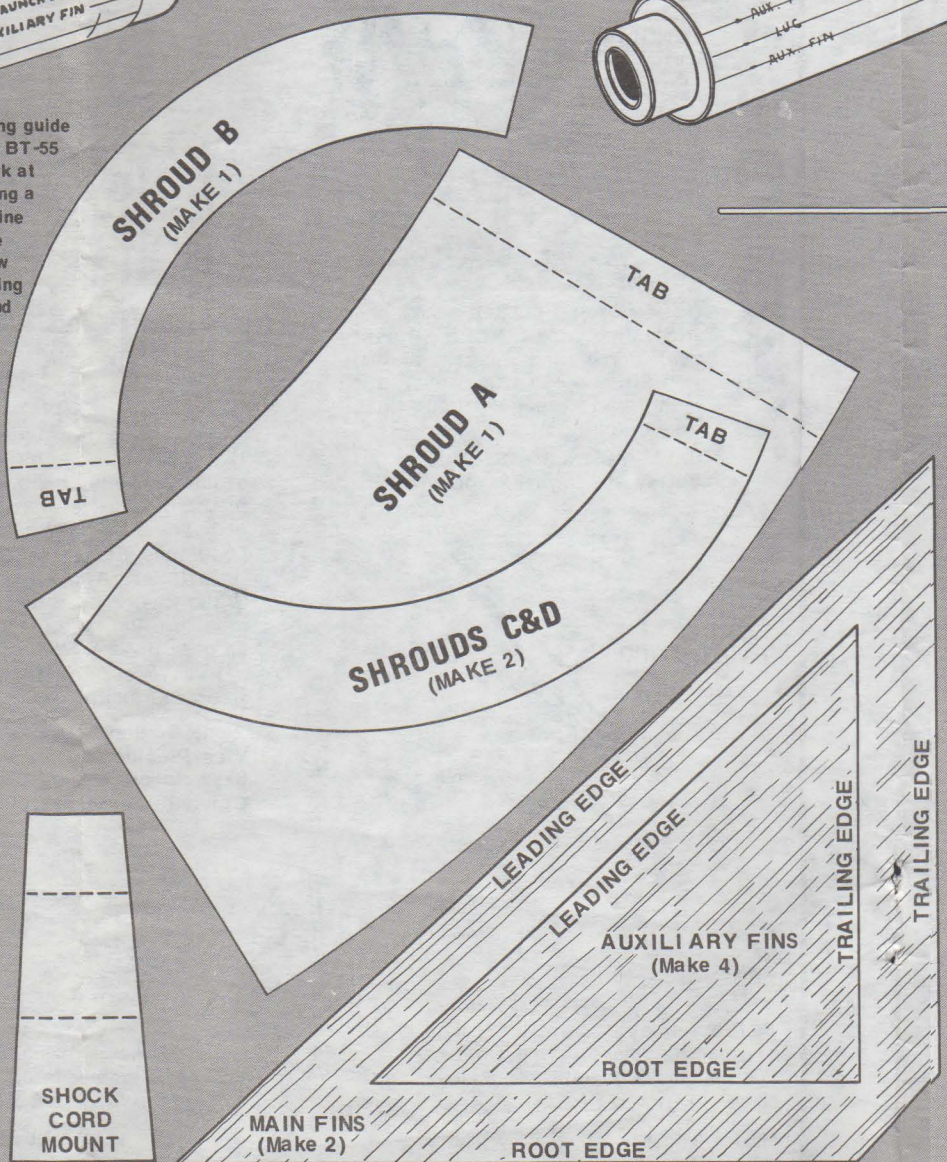
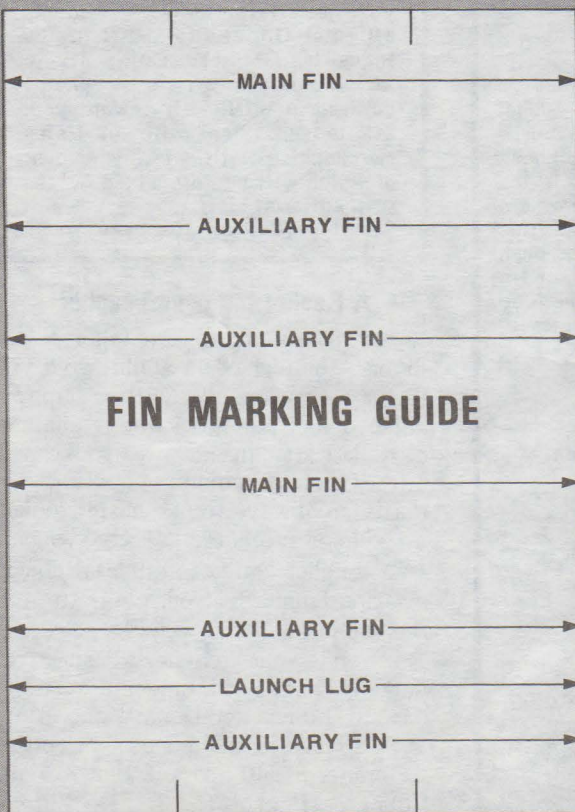

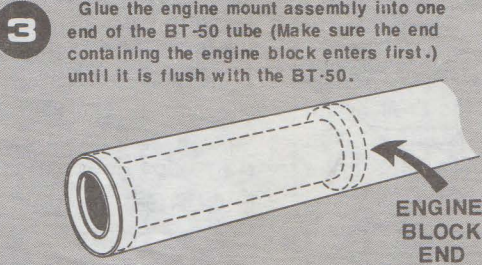

3 Glue the engine mount assembly into one end of the BT-50 tube (Make sure the end containing the engine block enters first.) until it is flush with the BT-50.

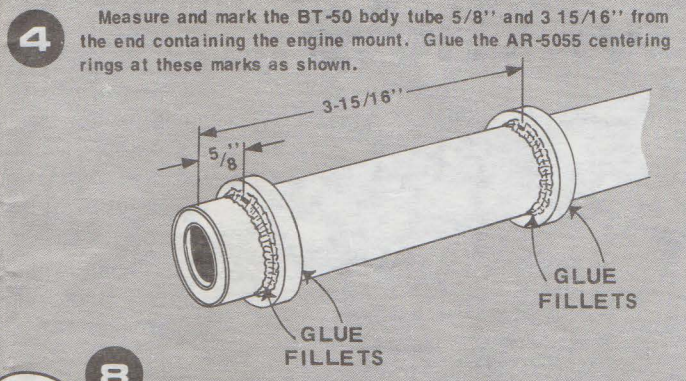

4 Measure and mark the BT-50 body tube $5/8''$ and $3\ 15/16''$ from the end containing the engine mount. Glue the AR-5055 centering rings at these marks as shown.

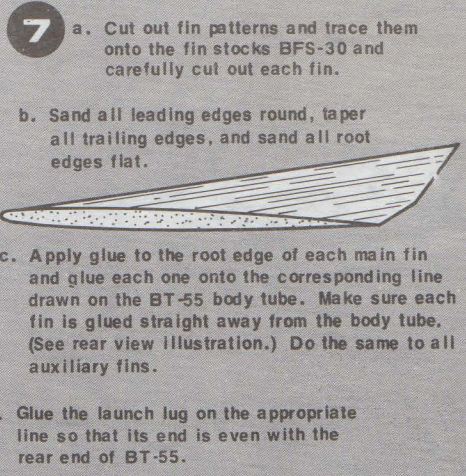

7 a. Cut out fin patterns and trace them onto the fin stocks BFS-30 and carefully cut out each fin.
 b. Sand all leading edges round, taper all trailing edges, and sand all root edges flat.
 c. Apply glue to the root edge of each main fin and glue each one onto the corresponding line drawn on the BT-55 body tube. Make sure each fin is glued straight away from the body tube. (See rear view illustration.) Do the same to all auxiliary fins.
 d. Glue the launch lug on the appropriate line so that its end is even with the rear end of BT-55.

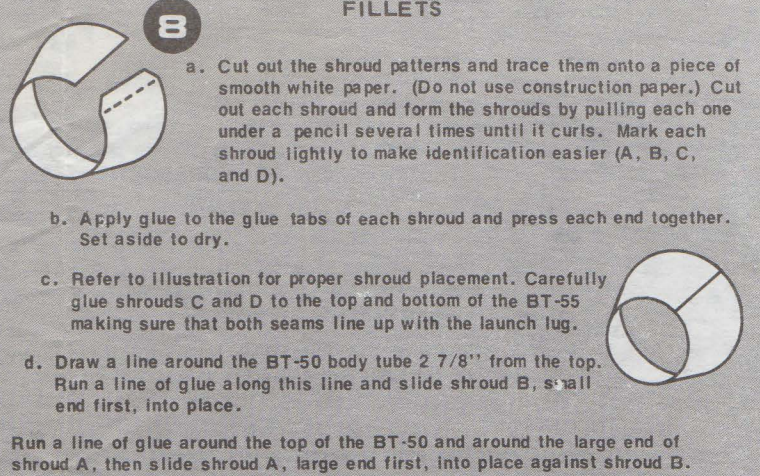

8 a. Cut out the shroud patterns and trace them onto a piece of smooth white paper. (Do not use construction paper.) Cut out each shroud and form the shrouds by pulling each one under a pencil several times until it curls. Mark each shroud lightly to make identification easier (A, B, C, and D).
 b. Apply glue to the glue tabs of each shroud and press each end together. Set aside to dry.
 c. Refer to illustration for proper shroud placement. Carefully glue shrouds C and D to the top and bottom of the BT-55 making sure that both seams line up with the launch lug.
 d. Draw a line around the BT-50 body tube $2\ 7/8''$ from the top. Run a line of glue along this line and slide shroud B, small end first, into place.
 e. Run a line of glue around the top of the BT-50 and around the large end of shroud A, then slide shroud A, large end first, into place against shroud B.

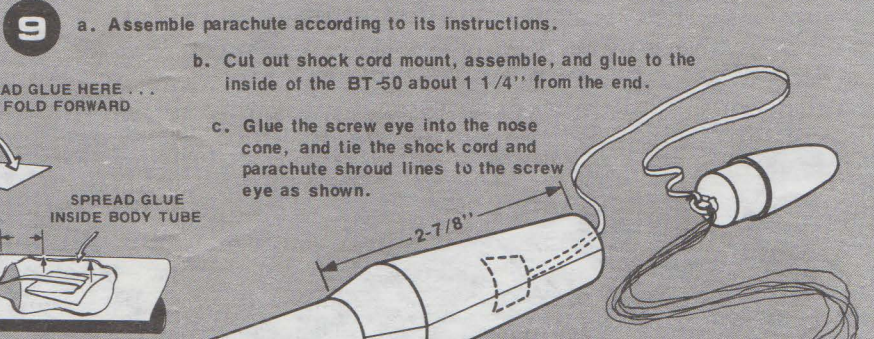

9 a. Assemble parachute according to its instructions.
 b. Cut out shock cord mount, assemble, and glue to the inside of the BT-50 about $1\ 1/4''$ from the end.
 c. Glue the screw eye into the nose cone, and tie the shock cord and parachute lines to the screw eye as shown.

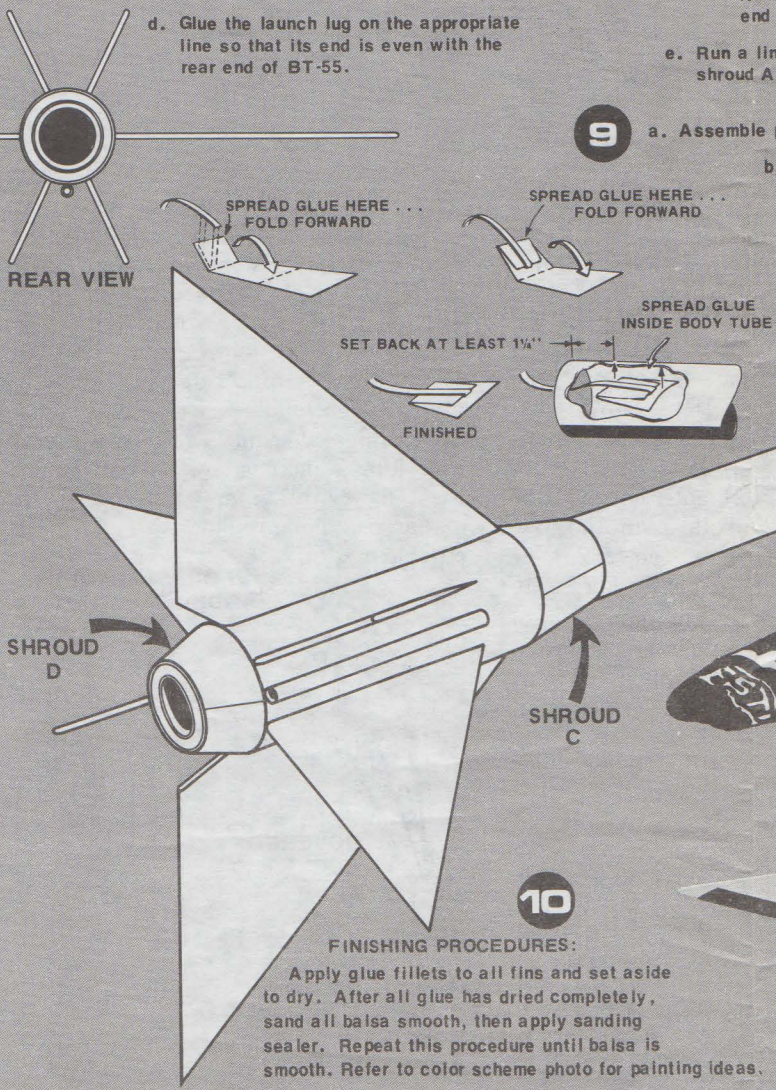

10 FINISHING PROCEDURES:
 Apply glue fillets to all fins and set aside to dry. After all glue has dried completely, sand all balsa smooth, then apply sanding sealer. Repeat this procedure until balsa is smooth. Refer to color scheme photo for painting ideas.

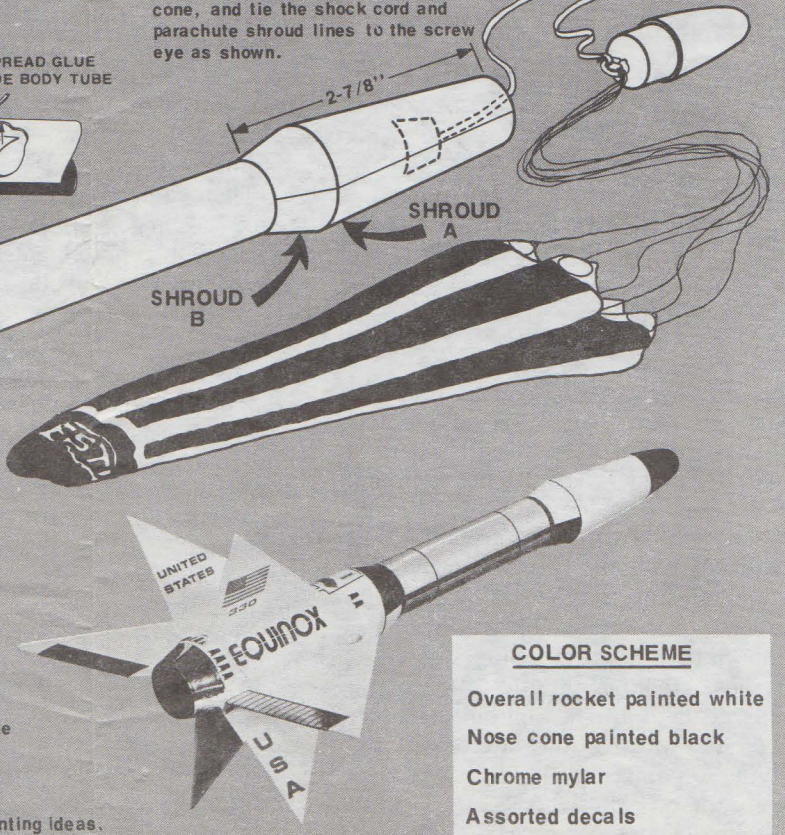

COLOR SCHEME
 Overall rocket painted white
 Nose cone painted black
 Chrome mylar
 Assorted decals

Multi-Stage Designs

Ultra High Altitude Kits

SHRIKE - Skill Level 3

Two-stage vehicle
Super high performance
Clear payload section
Pop - and - go staging
Over 29" tall
Colorful decals
Cat. No. K-46
Only \$4.95



BETA - Skill Level 2

Mini-engine powered
Sounding rocket
appearance
Streamlined design
Cat. No. TK-45
Only \$1.50

AVENGER - Skill Level 2

Two-stage vehicle
Sounding rocket appearance
Large payload section
High performance design
Tumbling booster
32" tall
Cat. No. K-38
Only \$3.50



SKYDART - Skill Level 4

"Business SST" styling
Streamlined design
Rear ejection system
Features internal power pod
Excellent reliability
Great performance
Cat. No. K-57 Only \$4.50



FALCON - Skill Level 3

Front engine B/G
Achieves flight times over
1-1/2 minutes
Easily trimmed
Simple-to-build
Excellent performance
Cat. No. K-13 Only \$1.50

NIGHTHAWK - Skill Level 4

Pop-pod B/G
Simplified construction
Easy-to-trim
Programmable glide phase
Recoverable power pod
Sleek design
Excellent flights
Cat. No. K-34 Only \$2.25

Boost Gliders

Conventional Rocket Lift-Off
With Amazing Glider Recovery

"C" engine special 9 for 99¢



- Super high performance
- Citation C-3 engines (equivalent to standard C6-3)
- Citation C-5 engines (equivalent to standard C6-5)

Now 9 for only 99¢

Hurry! Supply is limited.

Be sure to indicate Citation engine type when ordering. (Igniters not included)

RETIRED KIT SALE

Low, low, low prices
All kits worth at least
\$1.00 in parts alone.

STINGER Skill Level 1

Streamer recovery
Easy-to-build
High performance design
Sleek appearance
Cat. No. K-53 Only 60¢

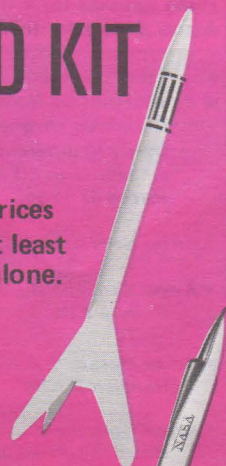

"ORIGINAL" STARBLAZER Skill Level 2

Deep space design
Forward crew cockpit canopy
Excellent sport model
Cat. No. K-31 Only 35¢



Take advantage of this tremendous saving!
Order now! Supplies are limited!

* "ORIGINAL" BETA Skill Level 2

Two-stage vehicle
Tumbling booster
Easy-to-build
High performance design
Parachute recovery
Cat. No. K-45
Only 35¢



* "ORIGINAL" MIDGET Skill Level 3

Giant performance
Two-stage vehicle
Sleek design
Cat. No. K-40
Only 40¢



* Note: Kit requires EM-520 engine adapter (not included) for Mini-Brute engines.

Designer's Special

Features more than 20 different parts

Perfect for constructing your original designs

Real surprise bag of miscellaneous parts and assorted supplies

• Includes many body tubes of various lengths and diameters



- Balsa fin stock
- 36" Nylon Parachute
- Assorted stage couplers
- Centering rings
- Shroud line
- Nose cones
- Model marking decal
- Shock cord
- Plastic body tubes

Quantities of some parts are limited — substitutions of equal value will be made when necessary.

At least a \$5.00 value for only \$1.95, Cat. No. 01465

FREE KITS

Offers expire
January 31, 1974
(Limit, one free kit per order.)



Your choice with \$5.00 order

Birdie (Skill Level 1)

- Flying shuttlecock
- Featherweight recovery
- Spin stabilization

Sprite (Skill Level 3)

- Futuristic design
- Quick change engine mount
- Less than 6" tall



My order is over \$5.00.
Please send me (check one)

- Birdie Cat. No. TK-44
OR
 Sprite Cat. No. K-15

Your choice with \$7.50 order

Apogee II (Skill Level 3)

- Two stage vehicle
- High performance design
- See-through payload section

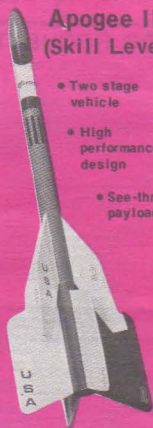

Nighthawk (Skill Level 4)

- Pop-pod boost glider
- Sleek design
- Programmable glide



My order is over \$7.50
Please send me:
(Check one.)

- Apogee II Cat. No. K-5
OR
 Nighthawk Cat. No. K-34

Your choice with \$10.00 order

Cobra (Skill Level 2)

- Three engine cluster
- Payload section
- Powerful lift-off

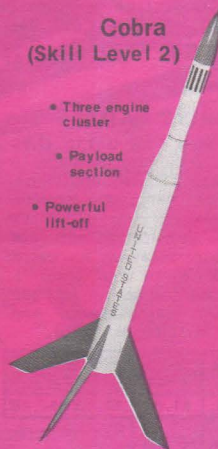

Farside (Skill Level 3)

- Three stage vehicle
- Ultra-high altitude probe
- Multi-purpose payload carrier



My order is over \$10.00
Please send me:
(Check one.)

- Cobra Cat. No. K-10
OR
 Farside Cat. No. K-12

Important Notice:
Quantities of some free kits are limited. When necessary, substitutions will be made.
HURRY!
ORDER TODAY!!

"D" POWERED VEHICLES

Super High Performance Models

CHEROKEE - D - Skill Level 2

Pre-cut fins
Quick change engine mount
Two-color decals
Super performance
Outa-sight flights
Sleek design
Parachute recovery
Recommended engines
D12-5, D12-7

Cat. No. K47 Only \$3.50

DEMON - Skill Level 2

Ultra high performance
Easy-track metallic decal
Quick change engine mount
Over 26" tall
Two-color decals
Parachute recovery
Recommended engine
D12-7

Cat. No. K-58
Only \$4.50

SANDHAWK - Skill Level 2

Sounding rocket vehicle
Super scale model
Plastic payload, nose cone, and fins
Over 30" tall
Dual parachute recovery
High performance design
Recommended Engine D12-5

Cat. No. K-51 Only \$3.50

OMEGA - Skill Level 3

Two-stage payload vehicle
Primary Cineroc carrier
Perfect for heavy payloads
Pop - and - go staging
Die-cut fins
Unique fin decals
Ultra high altitude flights
Parachute recovery
Recommended engines
Single stage flights - D12-5
Two stage flights - Booster D12-0,
Upper stage D12-7

Cat. No. K-52P Only \$5.95

GOBLIN - Skill Level 3

Ultra high altitude flights
Super fast lift-off
Far-out decals
Streamer recovery
Quick change engine mount
Recommended engine - D12-7

Cat. No. K-55 Only \$2.75

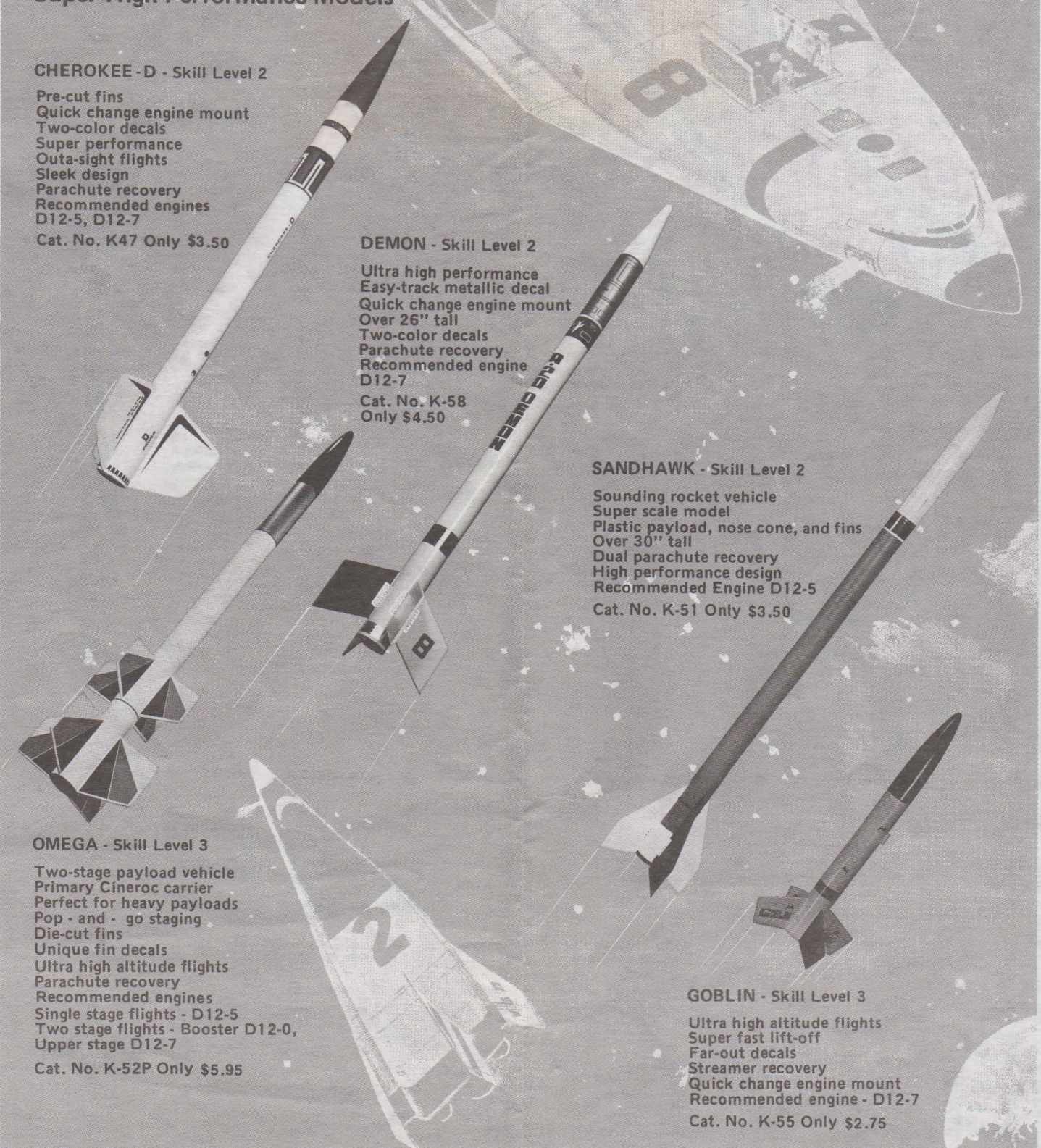



ORDER FORM

Dept. MRN-N

A SUBSIDIARY OF DAMON
TYPE OR PRINT PLAINLY IN INK

DATE: _____ Age _____

UPS is available in my area.

For Office Use Only	
Amt. Recd.	_____
Checked By	_____
No. Labels	_____
No. Pkgs.	_____
P	_____
N/F	_____

Your Name _____

Address _____

City _____

State _____ ZIP CODE _____
(If additional space is needed use a separate sheet of paper.)

Is this your first order? Yes No I am an EAC member.

Was your last order more than one year ago? Yes No

	Quan.	Cat. No.	Products Description	Unit Price	Total
1	<input type="checkbox"/>	#1447	EAC Membership Kit \$2.00		
2					
3					
4					
5					
6					
7					
8					
9					
10					
11					
12					
13					
14					
15					
16					

MOVED RECENTLY?

If you have moved since your last order please give your old address.

NAME _____

ADDRESS _____

CITY _____

STATE _____ ZIP _____

IMPORTANT READ THIS FIRST

Starting April 16, 1973 Estes Industries will begin shipping all mail orders originating east of Colorado by United Parcel Service (UPS). This means faster service for Estes rocketeers living east of Colorado. To take advantage of UPS service, your order must weigh at least one pound and your address must include a house number and a street name. Check the yellow pages of your telephone directory to see if your area is serviced by UPS. Remember, you must live east of Colorado, UPS is not yet available to the west.

SEPARATE HERE

Please do not write in this space.	AMOUNT THIS ORDER	
	Orders Under \$6.00 add 45¢ Additional Handling	.45
	Balance Due Estes Industries From Previous Order	

Mail to: **ESTES INDUSTRIES**
PENROSE, COLO. 81240

Priority Postage (If Desired) / State Sales Tax 3% (Colo. Residents Only)

TOTAL ENCLOSED _____

POSTAGE/PRIORITY MAIL

All retail orders are shipped postpaid in U.S. by regular land mail, UPS, or by the customer's choice of carrier which may require additional postage. For extra rapid delivery, you may request Priority Mail (Air Mail) service. Total up the shipping weights on the items you are ordering, then find the amount to allow for extra postage on the chart below. When your order is processed you will be charged only for the difference between regular parcel post and priority mail - any excess will be refunded.

WEIGHT (UP TO BUT NOT OVER) Allow	8 oz. to 1 lb.	2 lbs.	3 lbs.	4 lbs.	5 lbs.
		\$.70	\$.88	\$ 1.33	\$ 1.93
6 lbs.	\$ 3.13	\$ 3.73	\$ 4.33	\$ 4.93	\$ 5.53

For orders 7 ounces or less, send 8¢ per ounce.

PAYMENT ON ORDERS

Full payment must accompany all orders. Please send all remittances by either check or money order.

We do not ship orders C.O.D.

NOTICE:

Due to increased labor and material costs, Estes Industries has been forced to raise its prices effective August 25, 1973. Please refer to Catalog No. 732. We appreciate your past support and look forward to serving you in the future.

Thank you.

Estes Industries

arts and crafts are where it's at with arrow



Arrow Handicrafts is the world's leading manufacturer of handicraft kits. Tell your mom or big sister to ask for Arrow Handicrafts the next time she's looking for a relaxing hobby or something special for a friend. Ask your local Arrow dealer for these exciting products:

- Arrow Paint By Number Christmas Ornaments Over 390 different ornaments in kit form. Priced \$1 to \$5.
- Arrow Needlepoint Kits
- Arrow Yarn and Burlap Picture Kits
- Arrow Mosaic Tile Handicraft Kits
- Arrow Cork Bulletin Board/Wall Plaques
- Arrow Leather Handicraft Kits



JOIN NAR

The National Association of Rocketry is a must for the serious rocketeer. Membership includes insurance, competition sporting license, membership card, NAR decals, and subscription to the publication, MODEL ROCKETEER. For further details write to the National Association of Rocketry, Dept. E1, P.O. Box 178, McLean, Virginia 22101.

A Rocket for Your Teacher!

Want to do your teacher a real favor? Instead of an apple, give your teacher a rocket! We will be happy to send to your teacher a free Alpha model rocket kit.

Send your teacher's name and school address (include zip code) today to Education Department, Dept. 107, Estes Industries, Penrose, Colorado 81240 and ask that we send Educator Packet EP-2. Be sure to include your own name and address. Thanks!

Friend's Name _____

Address _____

City _____

State _____ Zip _____

Friend's Name _____

Address _____

City _____

State _____ Zip _____

flour, talcum powder, or colored Temptra powder paint into the rocket's parachute compartment. At ejection, the powder will quickly disperse into a small puff or cloud. This technique is often used at contests to give tracking stations a visual marker of a rocket's peak altitude. Pack your recovery wadding and parachute first. Then insert a square of wadding atop the parachute. Use more wadding for larger body tubes. This will prevent the powder from sifting down into the body tube. Add the powder and secure the nose cone. When launching against a clear blue sky, use a light colored powder. A dark color is easiest to spot against an overcast or cloudy sky background. It is a fun technique, but be prepared to find your rocket a bit messy after a couple of flights.

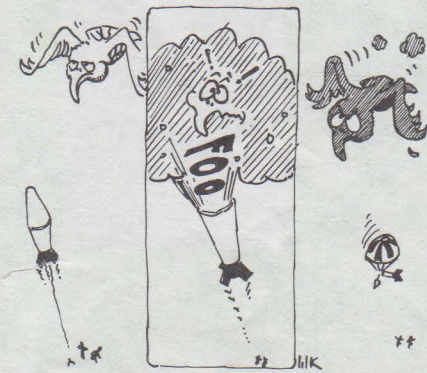

When launching a multi-stage bird, everyone wants to watch the whole show. But after the launch, no one seems to know what happened to the booster stages. Always assign one person to watch the first stage, another to watch the second stage, and so on as in Figure 4. The same procedure should be used when a payload is recovered separately, or for those rockets which eject the engine or power pod. Then you will be sure to recover all portions of your rocket.

FIGURE 4

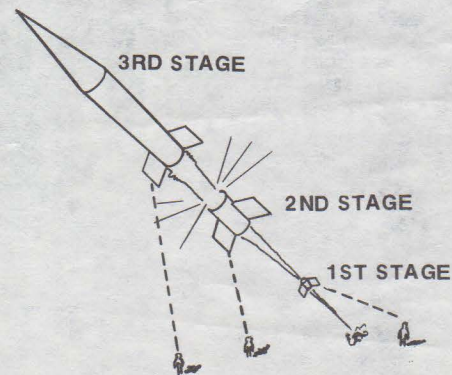

PARACHUTE PACKIN'

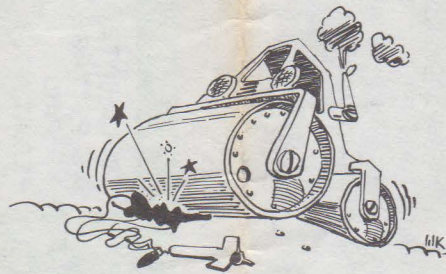

Flameproof recovery wadding is designed to protect your recovery system from the heat of the ejection charge. Always use enough wadding to fill the rocket body for a distance of 1-1/2 to 2 times the body diameter. Before launching, check each rocket's assembly instructions for the exact amount of wadding required. DO NOT pack it so tightly that it cannot be ejected. Loosely packed wadding works best. If your 'chute returns looking like a Swiss cheese or burnt shish kebab, then you're not using enough wadding. Be sure to wrap one end of the rocket engine with enough masking tape so that it makes a snug air-tight seal in the engine tube. This will prevent leakage of ejection gases past the engine.

FIGURE 5

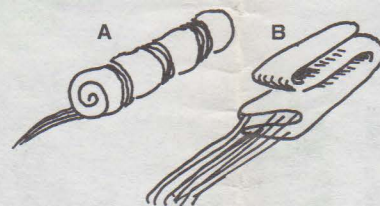

Considerable controversy still exists as to which is the best way to pack a parachute. Some prefer a tightly rolled and wrapped 'chute as in Figure 5A. This method is good when you must pack a large parachute into a small space. A tightly wrapped parachute will, however, take longer to open. Others prefer a loosely packed chute (B). Our observation and experience has been that the loosely packed (even sloppy) method gives the most reliable recovery. This is due to the ability of the loose edges and folds to catch the wind. The plastic material also has a tendency to "spring back" when loosely crumpled. Plastic 'chutes also have a special tendency to take a "set" after being stored for a while. When cold, they become stiff and are very stubborn to open. So just before launching, remove the parachute, open

it, refold, and repack it. For best results, always dust the 'chute lightly with talcum powder before folding, every other flight or so. This prevents the plastic from sticking to itself.

PARACHUTE MOD'S

FIGURE 6

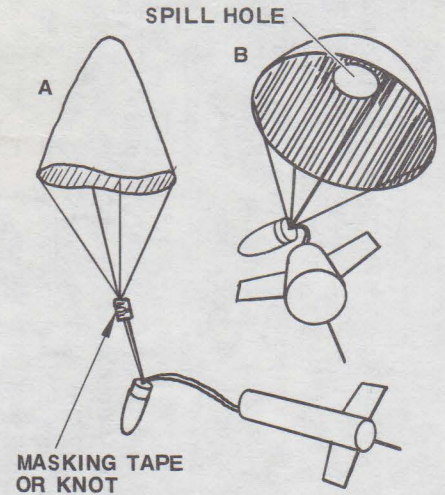

There are several ways to modify a parachute in order to make your rocket fall faster but safely. You can "reef in" or shorten the shroud lines as in Figure 6A by taping or tying a knot in the lines. The shorter you make the lines the less your 'chute can open. Shorten the shroud lines all the way and your parachute becomes an instant streamer. Or you can cut a "spill hole" (B) out of the parachute center. This decreases the parachute's drag and also seems to reduce the rocket's swaying movements during descent. Don't make the hole too large, or the parachute will not open at all.



Next issue, Part III; Rocket Recovery Types. In this article we will examine closely the operation of a typical recovery system and look at various types of rocket recovery.

- Exciting Articles
- Technical Reports
- Crazy Cartoons
- Free Plan

Here it is!
Your Sept./Oct. MRN
Featuring:



A SUBSIDIARY OF DAMON
ESTES INDUSTRIES
 PENROSE, COLO. 81240



BULK RATE
 U.S. POSTAGE
 PAID
 PERMIT NO. 1

“Design Of The Month Winners”

Congratulations to these Estes rocketeers for their outstanding entries. First place winners will receive a \$50 merchandise certificate and honorable mentions will be awarded \$5.00 certificates. Keep those designs coming, maybe you'll be our next winner.

JUNE 1973 - First Place: Ensign A. H. Barber III, FPO, New York (“The Pressure and Temperature Dependent Properties of Model Rocket Propellant”). Honorable Mention: Mike Rossi, Canon City, Colorado (“EQUINOX” Sport Design”).
Ed Nixon, Perkins, Oklahoma (“God-dard Rocket”), **Jim Amos, Mission Hills, California** (“Dyna-Soar”).
Larry Richardson, Grand Bay, Alabama (“Paraglider”). John E. Morris,

Yorktown, Indiana (“Mars Shuttle Booster”).

JULY 1973 - First Place: Leonard Rose, San Bruno, California (“Semi-Scale Hound Dog”). Honorable Mention: Danny Lin, Schenectady, New York (“Semi-Scale La Crosse”).
Steve Zwegemann, Austin, Texas (“Report - The Krushnic Effect: Its Native Causes and Effects on Model Rockets”), **Steven Doniluk, Yonkers, New York** (“Nike-Deacon, Nike-Hercules”), **Eugene Aikens, Dover, New Hampshire** (“Mini-Sprint”).
Glenn Frederick, Salem, New Hampshire (“Probe”), **Chris Hudachek, Stillwater, Minnesota** (“Unusual Model”).

BLAST-OFF!!

With more than 18,000 Estes Rocketeers Join the ESTES aerospace CLUB

Enjoy the fun and excitement of Estes model rocketry as an official EAC rocketeer. Membership includes Viper rocket kit, ID card, membership certificate, iron-on emblem, decal sheet, range box stickers, EAC stationery, tech manual, subscription to MODEL ROCKET NEWS, EAC Product Bulletin and Newsletter, Estes catalog, and a variety of exclusive club services.

Lift-off for fun! Join today!
 EAC membership - Only \$2.00.
 Check the EAC membership box on your MRN Order Form.

