



About Semroc Astronautics

Semroc Astronautics Corporation was started by Carl McLawhorn in his college dorm at North Carolina State University in November, 1967. Convincing a small group of investors in his home town of Ayden, North Carolina to invest in a small corporation, the company was re-incorporated as Semroc Astronautics Corporation on December 31, 1969.

Semroc produced a full line of model rocket kits and engines. At its peak, Semroc had twenty-five full time employees working at two facilities. One was for research and development, printing, shipping, and administration. The other was outside town and handled all production and model rocket engine manufacturing. For several years, Semroc was successful selling model rocket kits, supplies, and engines by mail-order and in hobby shops. In early 1971, Semroc became insolvent and had to close its doors.

After 31 years of dreams and preparations, Semroc Astronautics Corporation was reincorporated on April 2, 2002 with a strong commitment to helping put the fun back into model rocketry.

About the Hydra One™

The original Semroc Hydra VII™ was designed in 1969 as the seventh Semroc-Kit. Designed to be a high performance large cluster payload rocket, the Hydra VII™ was the most complex kit Semroc introduced. Named after a multi-headed monster in Greek mythology, the Hydra was a monster of a rocket with seven C engines! Construction was much more challenging than most other model rockets of the time. Igniting all seven engines was a major accomplishment, but rewarding flights were still possible.

After 40 years of wondering what a downscale would look like, the Hydra One™ was created as a 70% scale of the original. Using a single engine, flights up to 600 feet are possible. The payload section is dropped and the three chutes are reduced to a single chute on the Hydra One™. It is still a challenging build, but laser cut tubes and fins make the job a little easier. At a cost of about half the Hydra VII, this model will add many more modelers to the "Hydra" family.

SEMROC

Hydra One™

Baby Hydra VII

Precision Turned Balsa Nose Cones

Laser Cut Balsa Fins

Laser Slotted Tubes

Water Slide Color Decals

15" Parachute Recovery

*Design by
Carl
McLawhorn*

**FLYING
MODEL
ROCKET KIT**

**MADE IN THE
USA**

Made in the U.S.A by Semroc - Dayton, Ohio

Hydra One™ Kit No. KA-18

Specifications	Engine	Approx. Altitude
Body Diameter 1.17" (3.0 cm)	A8-3	100'
Length 22.2" (56.4 cm)	B6-4	300'
Fin Span 4.9" (12.5 cm)	C6-5	650'
Net Weight 1.9 oz. (53.9 g)		

Skill Level 3

March 17, 2009, May 3, 2016

Copyright © 2009 Semroc
www.semroc.com

Parts List

EXPLODED VIEW

- A 1 Balsa Nose Cone... BC-1122
- B 3 Balsa Nose Cones... BC-510S
- C 1 Body Tube..... ST-11125
- D 6 Body Tubes..... ST-560S
- E 1 Body Tube..... BT-80R
- F 1 Body Tube..... ST-560
- G 1 Body Tube..... ST-730E
- H 1 Screw Eye SE-10
- I 1 Centering Ring..... CR-57
- J 1 Engine Hook EH-28
- K 1 Elastic Cord..... EC-124
- L 2 Centering Rings CR-5-11
- M 1 Launch Lug LL-2A
- N 1 Kevlar® Thread..... SCK-12
- O 3 Wood Dowels WD-202
- P 1 Chute Pak..... CP-12-24
- Q 1 Laser Cut Fins FA-18
- R 1 Decal DKV-69
- S 1 Shroud Sheet..... IKA-18S

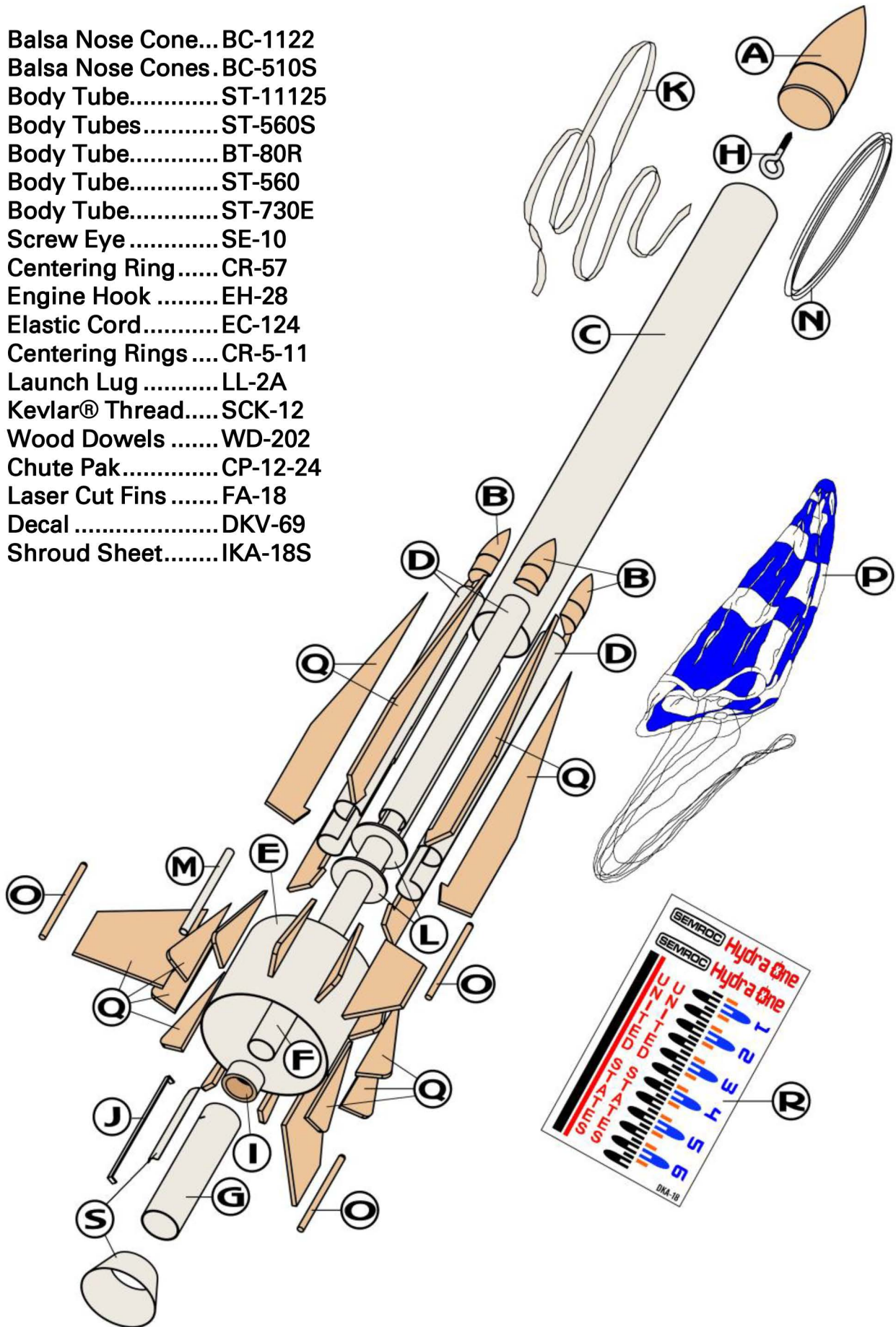

BEFORE YOU START!

Make sure you have all the parts included in this kit that are listed in the Parts List in the center of these instructions. In addition to the parts included in this kit, you will also need the tools and materials listed below. Read the entire instructions before beginning to assemble your rocket. When you are thoroughly familiar with these instructions, begin construction. Read each step and study the accompanying drawings. Check off each step as it is completed. In each step, test-fit the parts together before applying any glue. It is sometimes necessary to sand lightly or build-up some parts to obtain a precision fit. If you are uncertain of the location of some parts, refer to the exploded view in the center of these instructions. It is important that you always ensure that you have adequate glue joints.

TOOLS

In addition to the parts supplied, you will need the following tools to assemble and finish this kit.



ASSEMBLY

1. These instructions are presented in a logical order to help you put your Hydra One™ together quickly and efficiently. Check off each step as you complete it and we hope you enjoy putting this kit together.

FIN PREPARATION

2. Lightly sand each side of the laser-cut fins (FA-18). Carefully push the laser-cut fins from their sheet. Start at one point on each fin and slowly and gently work around the fin.

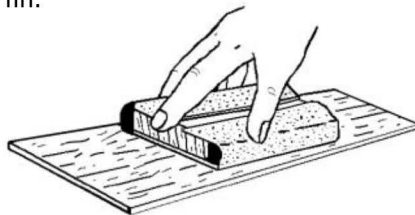

3. Stack all the fins in groups of three fins each. Line each group up squarely and sand the fins back and forth over some fine sandpaper to get rid of the hold-in tabs as shown below.



4. Repeat for all three sets of fins. Round all leading edges. Round or taper all trailing edges. Leave the tip and root edges flat. Use the diagram to identify edges and fin types.

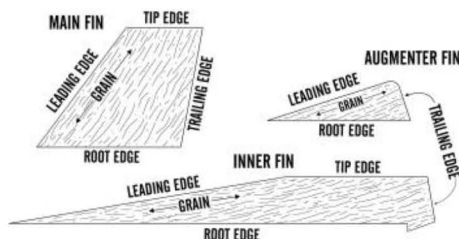

5. Since the fins are so close together after they are glued to the body tubes, it is easier to fill the balsa fins now instead of after they are glued in place. For a smooth professional looking finish, fill the wood grain with balsa fillercoat or sanding sealer. When dry, sand with fine sandpaper. Repeat until smooth.



STUFFER TUBE

6. Fit the small Centering Ring (CR-57) over the un-slotted small tube (ST-560). It may be necessary to sand the inside edge of the centering ring to get a good fit. Remove the ring and apply a bead of glue inside the ring.

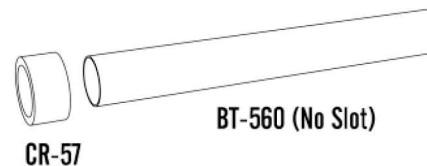

7. Slide it back over the small tube until the ends are even. Set aside and allow to dry.

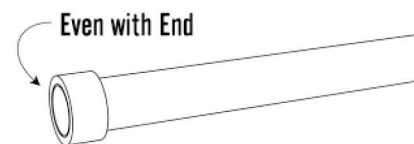

ENGINE MOUNT

8. Bend the engine hook (EH-28) slightly so it forms a slight bow in the direction shown.

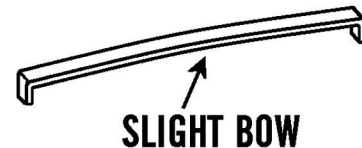

9. Insert one end of the engine hook (EH-28) into the pre-punched slit in the engine tube (ST-730E).

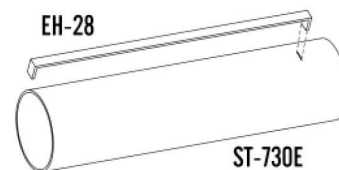

10. Cut out the engine hook cover from the shroud sheet. Pre-fold it along the lines as shown below. Apply a bead of glue to the bottom of the cover and place it over the engine hook. Keep glue away from the engine hook that is exposed. Allow to dry.

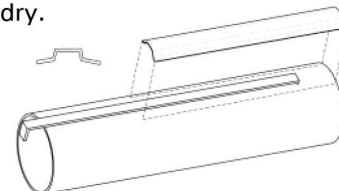

- 11. Apply a bead of glue inside the top of the engine tube. Slide the stuffer tube assembly into the engine tube until the centering ring is even with the top of the engine tube. Place a piece of scrap balsa under the free end of the stuffer tube to keep it aligned. Rotate the assembly 90 degrees to make sure the two tubes are parallel. Allow to completely dry.

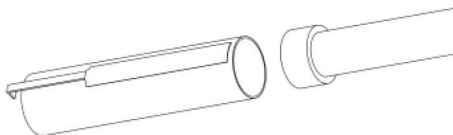

ADD TUBES

- 12. Align one of the slotted tubes (ST-560S) with the slot centered over the engine hook cover and the end of the slot flush with the end of the engine tube. Apply a small amount of glue to tack the tube in place. Sight from the top to make sure the tubes are all parallel. Apply a thicker bead of glue to hold the assembly together. Allow to dry completely.

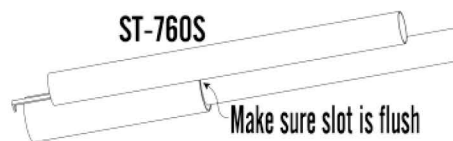

- 13. Add a second slotted tube making sure the slot is against the engine tube and that it is snug against the first tube. Check for alignment, then tack into place.

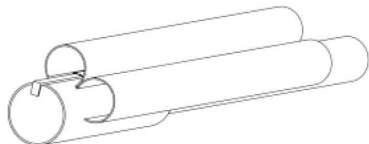

- 14. Tack the remaining four slotted tubes in place. Check for alignment, then run a bead of glue along all the joints.

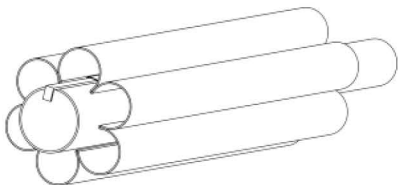

MAIN TUBE

- 15. Slide one of the large centering rings (CR-5-11) over the stuffing tube. Apply a bead of glue along all the contact points, then push the ring into place against the six slotted tubes. Wipe all glue from the exposed ends of the slotted tubes. Nose cones will be added to them later. Allow to dry.



- 16. Tie a knot in one end of the Kevlar® shock cord (SCK-12). Insert it into the remaining centering ring (CR-5-11) with the knot as shown. Insert the ring over the end of the stuffing tube, capturing the Kevlar shock cord. Leave about 1/8" from the top end and run a bead of glue around both sides at the joint between the ring and tube. Make sure a generous bead is applied to the knot.

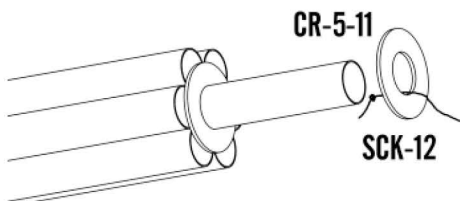

- 17. Tie the free end of the Kevlar® shock cord to one end of the elastic cord (EC-124) using an over-hand knot.

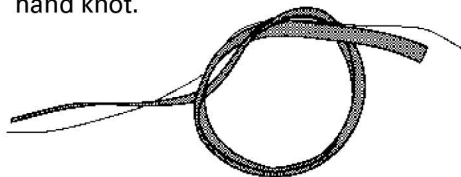

- 18. Stuff the Kevlar® shock cord and elastic cord into the stuffer tube to keep them out of the way for now.

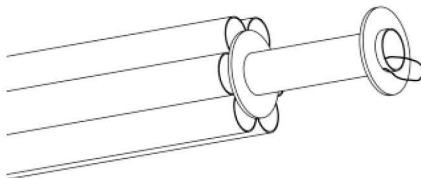

- 19. Apply a bead of glue inside one end of the large body tube (ST-11125). Insert the engine assembly into the main tube until the end of the tube is over the bottom centering ring. Allow to dry in a vertical position.

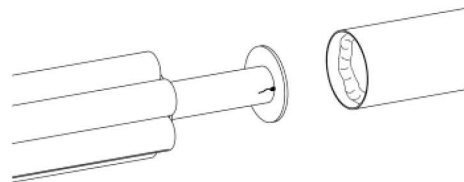

INTERSTAGE SHROUDS

- 20. The three small nose cones will be split in half to make the six inter-stage shrouds. Carefully cut one nose cone in half, forming two identical pieces. The best method involves the use of a small micro-saw, but a hobby knife or single edge razor blade will work as well. Follow the same procedure until you have six identical nose cone halves

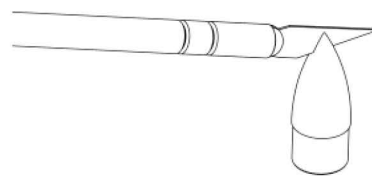

- 21. Using medium sandpaper, wrap a piece around the large (ST-11125) body tube with the sanding surface outward. Sand the nose cones up and down the length of the tube until they have the shape indicated below. Sand with care to obtain the exact shape. Do not take off too much balsa.

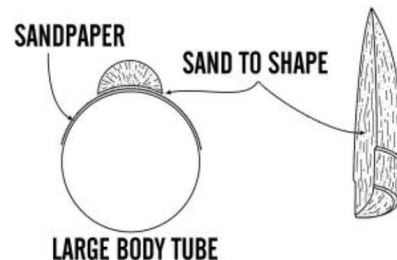

- 22. Place the sanded nose cones inside the top of the six outer body tubes in the engine assembly. They should fit against the large body tube. If the nose cone does not fit, it will have to be sanded more. When the correct fit is achieved, all the nose cones should be glued in position.

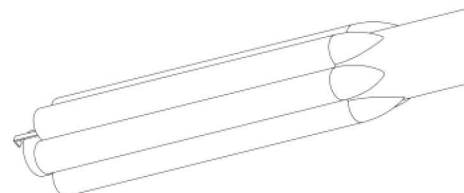

INNER FINS

- 23. Glue the first inner fin in between two of the slotted tubes as shown below. Make sure the trailing edge tab is even with the bottom of the slotted tube.

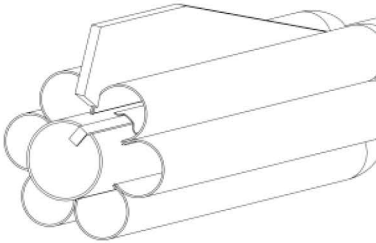

- 24. Glue the remaining five inner fins using the end view below as a guide for proper alignment.

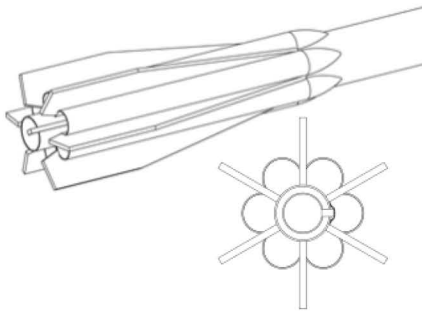

LAUNCH LUG

- 25. Glue the launch lug (LL-2A) at one of the inner fin-to-slotted tube joints just above the end of a slotted tube.

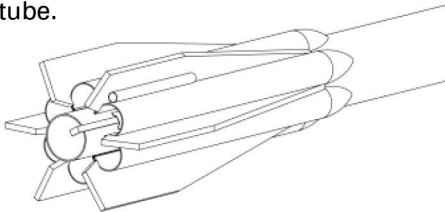

AUGMENTOR SHROUD

- 26. Using the fin alignment guide on the shroud sheet, mark the largest body tube (BT-80R). Each of the twelve marks on the outside of the tube will align the augmentor fins. Mark the six inner points that will align the inner fins. Find a convenient channel or groove such as a partially open drawer, a door jamb, or a piece of molding. Using the channel, extend the marks the full length of the tube to provide lines for aligning the fins.

- 27. Check the augmentor shroud for fit. It might be necessary to sand a small amount off the tip edge of the inner fins to get a snug fit. Align the marks on the inside of the tube with the inner fins. Line up the shroud with each end of the inner fins. Run a fillet of glue along each joint of the inner fins to the shroud. Stand on end and allow to dry.

BT-80R

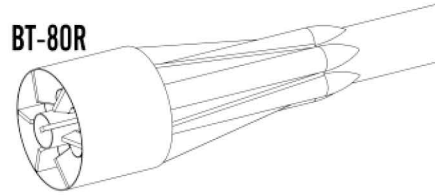

MAIN FINS

- 28. Glue one of the main fins on the augmentor shroud directly over one of the inner fins. Sight the fin from the top. It should look like an extension of the inner fin. Allow the glue to set. Skip one inner fin and glue the second fin directly over the next one. Repeat for the third main fin. There should be a main fin aligned with every other inner fin as shown. Allow all the joints to dry, then run a good fillet of glue along each fin joint.

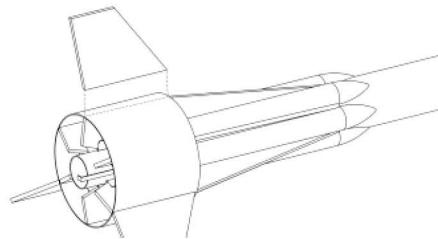

AUGMENTOR FINS

- 29. Space all twelve augmentor fins on the lines previously marked on the shroud. There should be four augmentor fins between each pair of main fins. Allow them to dry and run a fillet of glue along each joint.

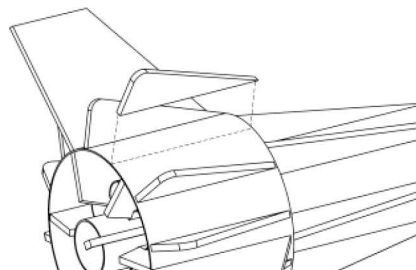

FIN PODS

- 30. Round the top end of each fin pod (WD-202). Glue one to the tip edge of each main fin, even with the bottom of the fin. Make sure it is parallel with the fin.

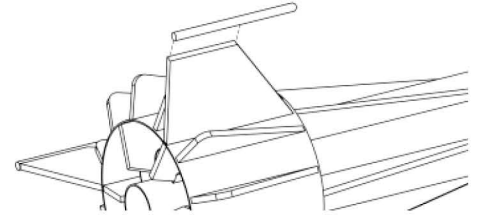

NOZZLE

- 31. Cut out the nozzle shroud from the pattern sheet. Form it into a cone and apply a small amount of glue to the tab on one end as denoted by the dotted line. Attach the free end over the glue so its end is even with the dotted line and hold in place until the glue sets.

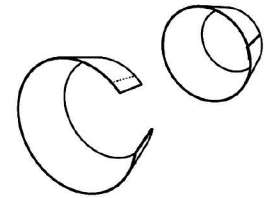

- 32. Center the nozzle between the six inner fins. Apply a bead of glue along each joint.

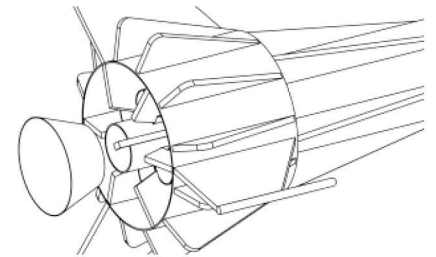

NOSE CONE

- 33. Insert the nose cone (BC-1122) in the body tube and check for proper fit. The nose cone should be snug to hold itself in alignment. If it is too loose, add masking tape. If it is too tight, sand the shoulder slightly.

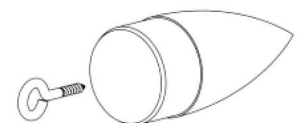

FINAL ASSEMBLY

34. Assemble the chute (CP-12-24) using instructions to make a 15" chute. Pull the lines tight on the chute and make sure they are all of equal length. Attach the chute by tying them to the screw eye. Put a drop of glue on the joint to keep the lines from moving. Shake the elastic cord free and out of the top of the main tube. Attach the free end of the elastic cord to the screw eye. Put a drop of glue on that joint as well.

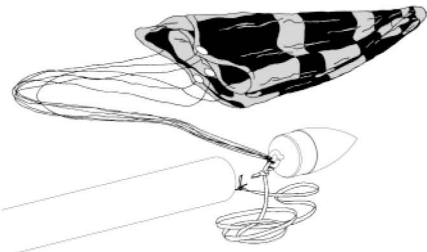

FINISHING

35. After all balsa surfaces have been prepared, wipe off all balsa dust with a dry cloth. First spray the model with an enamel primer. Choose a high visibility color like white or light gray for the final color.

36. Spray painting your model with a fast-drying enamel will produce the best results. PATIENCE...is the most important ingredient. Use several thin coats, allowing each coat to completely dry before the next coat. Start each spray a few inches above the model and end a few inches below the model. Keep the can about 12" away and use quick light coats. The final coat can be a little heavier to give the model a glossy wet-looking finish.

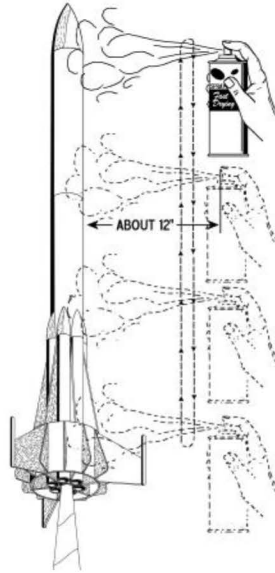

37. After the paint has dried, decals should be applied. The decals supplied with the Hydra One™ are waterslide decals. Each decal should be cut separately from the sheet. Think about where you want to apply each decal and check for fit before wetting the decal. Use the cover photo for suggested placement. Dip each decal in a small dish of water that has a drop of detergent. It will take about 30 seconds before the decal is loose enough to apply.



38. Slide the decal in place and use the paper backing to work the bubble out. Repeat for all the decals.

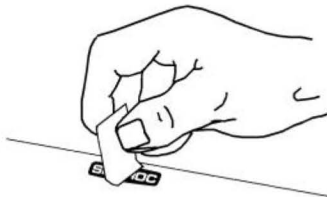

FLIGHT PREPPING

39. Mounting the engine: Insert the engine and make sure the engine hook keeps the engine in snugly. The hook may be slightly bent to make sure the engine is retained.

40. Apply a few sheets of recovery wadding in the top of the main body tube. Fold the parachute and pack it and the shock cord on top of the recovery wadding. Slide the nose cone into place, making sure it does not pinch the shock cord or parachute.

41. Refer to the model rocket engine manufacturer's instructions to complete the engine prepping. Different engines have different igniters and methods of hooking them up to the launch controllers.

42. Carefully check all parts of your rocket before each flight as a part of your pre-flight checklist. Launch the Hydra One™ from a 1/8" diameter by 36" long launch rod.

43. After each flight, promptly remove the spent engine casing and dispose of properly.

SEMROC

Hydra One™

Baby Hydra VII

**Precision Turned Balsa
Nose Cones**

Laser Cut Balsa Fins

Laser Slotted Tubes

**Water Slide
Color Decals**

**15" Parachute
Recovery**

*Design by
Carl
McLawhorn*

FLYING
MODEL
ROCKET KIT

Made in the U.S.A by Semroc - Dayton, Ohio

Hydra One™ Kit No. KA-18

Specifications	Engine	Approx. Altitude
Body Diameter 1.17" (3.0 cm)	A8-3	100'
Length 22.2" (56.4 cm)	B6-4	300'
Fin Span 4.9" (12.5 cm)	C6-5	650'
Net Weight 1.9 oz. (53.9 g)		

Skill Level 3