



About Semroc Astronautics Corporation

Semroc Astronautics Corporation was started by Carl McLawhorn in his college dorm at North Carolina State University in November, 1967. Convincing a small group of investors in his home town of Ayden, North Carolina to invest in a small corporation, the company was re-incorporated as Semroc Astronautics Corporation on December 31, 1969.

Semroc produced a full line of model rocket kits and engines. At its peak, Semroc had twenty-five full time employees working at two facilities. One was for research and development, printing, shipping, and administration. The other was outside town and handled all production and model rocket engine manufacturing. For several years, Semroc was successful selling model rocket kits, supplies, and engines by mail-order and in hobby shops. In early 1971, Semroc became insolvent and had to close its doors.

After 31 years of dreams and preparations, Semroc Astronautics Corporation was reincorporated on April 2, 2002 with a strong commitment to helping put the fun back into model rocketry.

About the Arcas™

The Semroc Arcas™ is a 1/3 scale model of the famous small sounding rocket produced in the 1950's and 1960's by Atlantic Research Corporation. There were over 14,000 Arcas rockets produced and they flew from over 55 launch sites around the world. The primary purpose was to extend the rockets data collection capability to over 200,000 feet, but their payloads were as diverse as cameras, biological, chemical, and inflatable shapes.

This model has a precision shaped scale balsa nose cone of the original No. 5A, laser-cut balsa fins, ejection baffle, long elastic cord, large chute, and 18mm engine mount. It is the perfect size for demo flights on a small field and is easy to build for first time scale builders.

July 5, 2011, September 29, 2015

Copyright © 2011 Semroc
www.semroc.com



SEMROC
ARCAS™
1/3 SCALE MODEL

**Famous Sounding
Rocket made by Atlantic
Research Corporation**

Ejection Baffle

**Precision Turned
Balsa Nose Cone**

**Laser Cut
Balsa Fins**

**Water Slide
Decal**

**15" Parachute
Recovery**

*Design by
Carl McLawhorn*

**MADE IN THE
USA**

**FLYING MODEL
ROCKET KIT**

Made in the U.S.A by Semroc - Dayton, Ohio

ARCAS™

Kit No. KS-8

Specifications	Engine	Approx. Altitude
Body Diameter 1.54" (3.9 cm)	B6-4	250'
Length 30.4" (77.2 cm)	C6-5	600'
Fin Span 5.0" (12.7 cm)	D16-5	1200'
Net Weight 2.4 oz. (68.1 g)		

Skill Level 2

Parts List

EXPLODED VIEW

- A 1 Balsa Nose Cone... BNC-58AC
- B 2 Body Tube..... BT-58AC
- C 1 Body Tube..... ST-730
- D 1 Tube Coupler JT-58C
- E 1 Ring Set CR-KS-8
- F 1 Laser Cut Fins FS-8
- G 1 Thrust Ring TR-7
- H 1 Elastic Cord..... EC-136
- I 1 Screw Eye SE-10
- J 1 Chute Pak..... CP-12-24
- K 1 Paper Shroud..... IKS-8S
- L 2 Launch Lugs LL-2AM
- M 1 Decal DKS-8

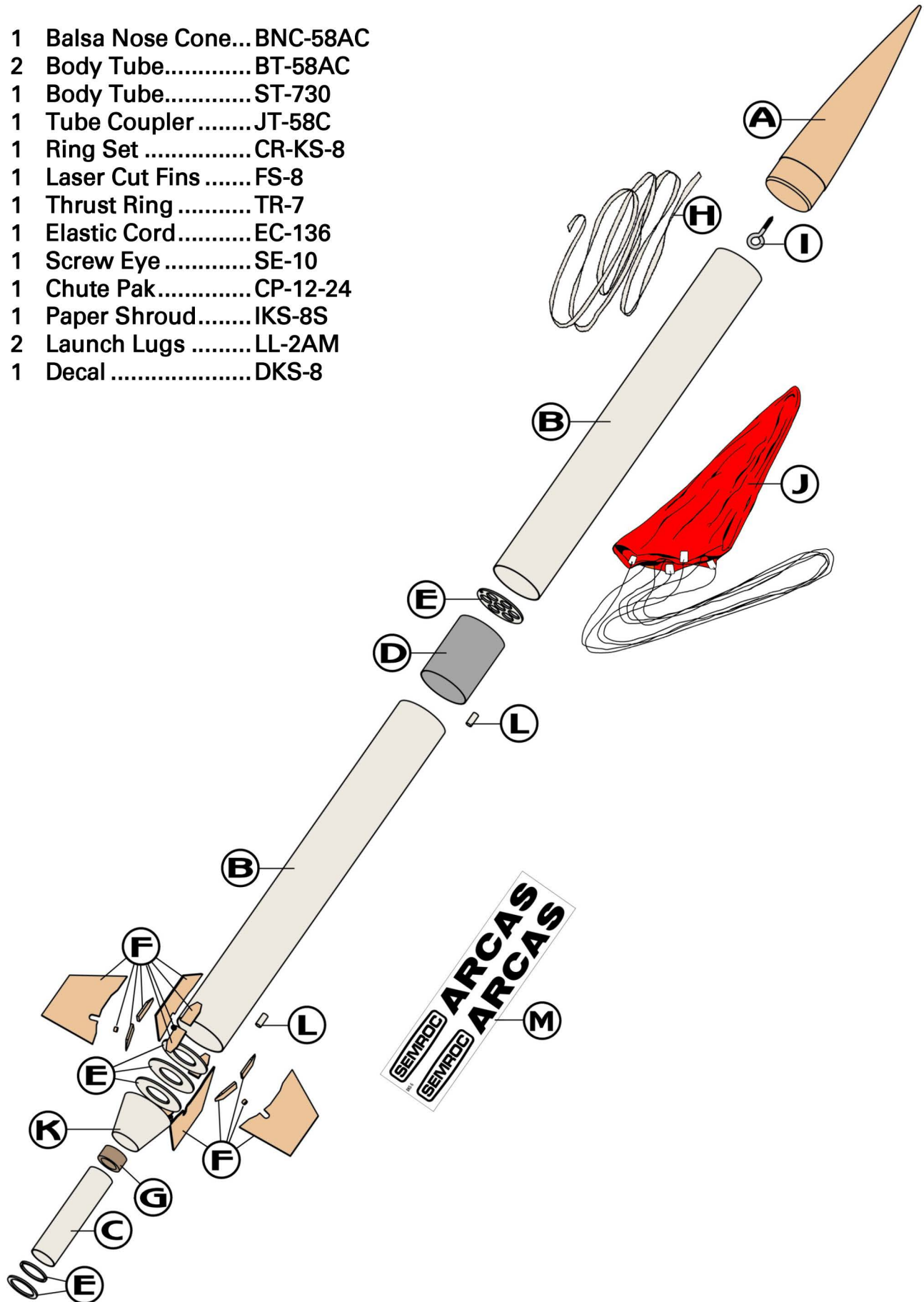

BEFORE YOU START!

Make sure you have all the parts included in this kit that are listed in the Parts List to the left. In addition to the parts included in this kit, you will also need the tools and materials listed below. Read the entire instructions before beginning to assemble your rocket. When you are thoroughly familiar with these instructions, begin construction. Read each step and study the accompanying drawings. Check off each step as it is completed. In each step, test-fit the parts together before applying any glue. It is sometimes necessary to sand lightly or build-up some parts to obtain a precision fit. If you are uncertain of the location of some parts, refer to the exploded view to the left. It is important that you always ensure that you have adequate glue joints.

TOOLS

In addition to the parts supplied, you will need the following tools to assemble and finish this kit. Masking tape is also required.



ASSEMBLY

1. These instructions are presented in a logical order to help you put your Arcas™ together quickly and efficiently. Check off each step as you complete it and we hope you enjoy putting this kit together.

FIN PREPARATION

2. Sand the fins with a slight taper from the root edge to the tip edge. The root edge should be .092" and the tip edge should be .070" when finished. Mark a mid-line on the front and back of each fin from the center of the root edge to the center of the tip edge. Taper each edge as shown in the cross section. The leading edge and trailing edge should be about .010". Apply some thin CA glue around all the edges to reinforce them and wipe before it dries. For sport scale, all the edges except the root edge may be rounded.

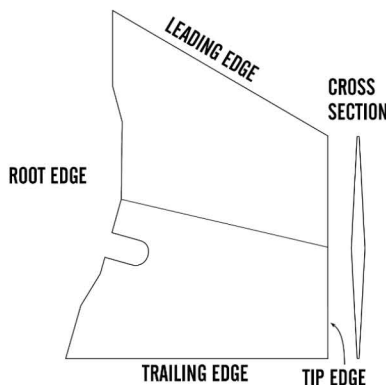

3. Sand all eight of the root edge plates as shown below. Slightly round all the top edges just enough to remove the sharp corners.

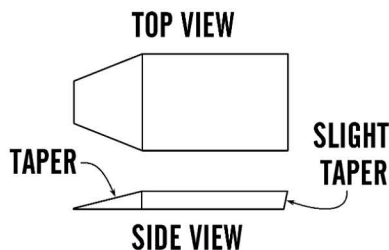

4. Fit pairs of root plates inside the root edge cavity on the main fins. The small bevel may be sanded to allow the two pieces to fit properly.

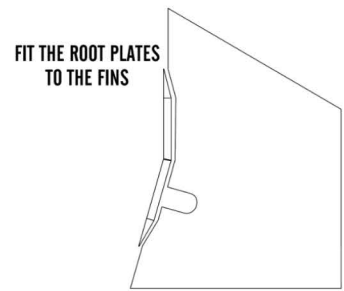

5. When a proper fit is achieved, apply glue along the center of the two plates and glue one of the fins to the two plates. Make sure they are centered and a tight fit is formed. Repeat with the other three fins.

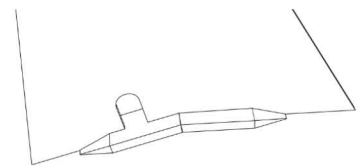

6. Punch out and sand all four of the simulated bolt heads. Center one on each root plate and centered inside the slot in the fin. Make sure the hex cavity is to the outside as shown.

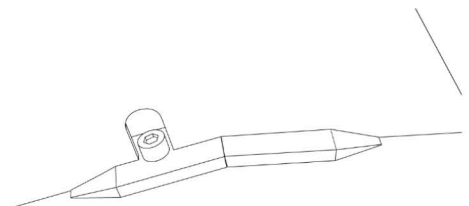

ENGINE MOUNT

7. Punch out the two smallest rings from the ring sheet (CR-KS-8). Align the largest of the two rings even with one end of the engine tube (ST-730).

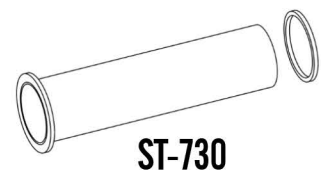

- ❑ 8. Slide the smaller ring over the top of the engine tube and against the larger ring.

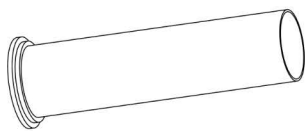

- ❑ 9. Use cyanoacrylate glue (CA) to seal the edges of the rings and the bottom of the engine tube. Wipe off any excess from the inside of the tube. **You must use CA. Yellow glue will not work well!** Allow to dry.



- ❑ 10. Apply a bead of glue inside the top of the engine tube and insert the thrust ring (TR-7) until it is flush with the end of the engine tube. Wipe any excess glue from inside the tube.

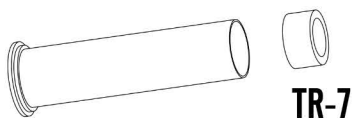

- ❑ 11. Carefully cut out the paper shroud (IKS-8S). Roll the shroud carefully, forming it into a cone with the glossy printed side outward. Form this carefully to avoid creasing the paper. Apply glue on the indicated section, line up the edge with the dotted line and press together on a flat surface. Set the shroud aside to dry.

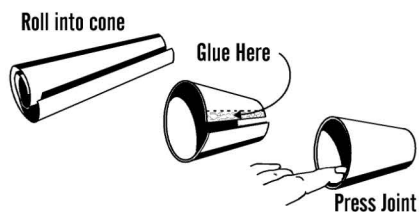

- ❑ 12. Punch out the three identical centering rings from the ring sheet (CR-KS-8). Slide the shroud, small end first over the engine tube assembly. It should go over the small ring and against the larger ring on the bottom of the engine tube. Slide one of the centering rings over the engine tube.

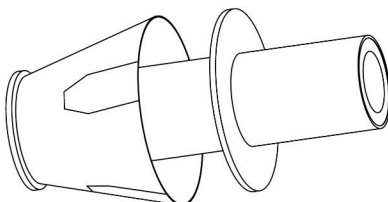

- ❑ 13. Slide the centering ring down the engine tube until it is just against the inside top edge of the shroud. It should be recessed slightly. Apply a bead of glue around the centering ring and tube joint. Apply a thin bead of glue around the outer edge of the centering ring and the inside edge of the shroud. Use your finger to apply a small fillet of glue around the lower ring where it contacts the shroud. Allow to dry.

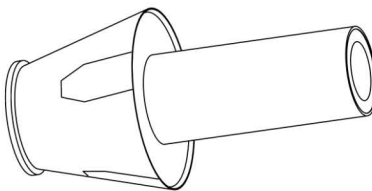

- ❑ 14. Slide a second centering ring over the engine tube until it is about 1/16" from the edge of the shroud and apply a bead of glue around the joint it makes with the engine tube.

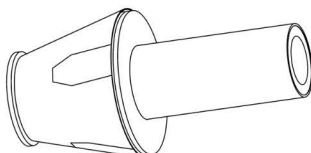

- ❑ 15. Slide the third centering ring down the engine tube until it is about 1/4" from the top of the engine tube and apply a bead of glue around both sides of the joint it makes with the engine tube.

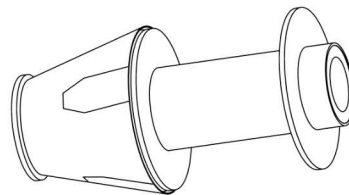

EJECTION BAFFLE

- ❑ 16. Punch out all the holes from the remaining baffle ring (EBR-58) on the ring sheet (CR-KS-8). Insert one end of the elastic shock cord (EC-136) into the small slot near the edge of the ring. Tie a knot in the end and pull it until the knot is against the ring. Apply a generous bead of glue on the knot. Align the ring on one end of the coupler tube (JT-58C) and glue it in place so the outer edge of the baffle is even with the coupler tube.

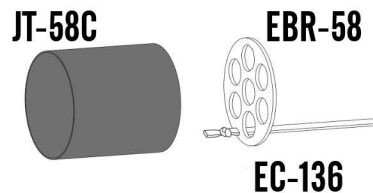

- ❑ 17. Apply a generous bead of glue inside the coupler tube against the joint between the baffle ring and the coupler tube. Glue the end of the elastic cord to the coupler tube.

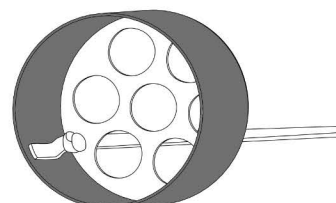

- ❑ 18. Test fit the ejection baffle in one of the large body tubes (BT-58AC). Feed the free end of the elastic cord through the tube and out the top. Apply a bead of glue just inside the body tube and insert the baffle halfway into the tube, leaving the bottom half of the baffle exposed. Keep the elastic cord away from the glue as much as possible.

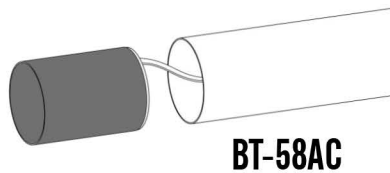

- ❑ 19. Before the glue has completely dried, apply a bead of glue in one end of the remaining large body tube (BT-58AC) and insert the exposed end of the baffle into the tube. Roll the assembly on a clear flat surface to make sure the body tubes are aligned. Continue rolling until the glue sets.

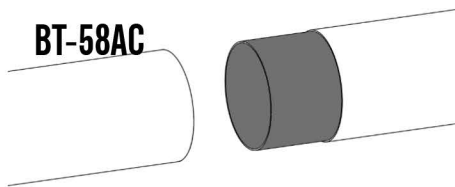

GLUE MOUNT

- ❑ 20. Apply a generous bead of glue inside the main body tube assembly in the end opposite the elastic cord. Apply a bead of glue around the top edge of the ring nearest the top of the shroud. Slide the engine mount inside the tube until the shroud is against the main body tube. Roll the assembly to allow the glue to pool against the tube, then allow the assembly to dry in a vertical position.

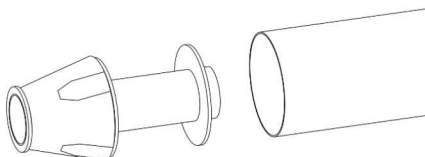

MARK TUBE

- ❑ 21. Using an angle or a door facing, draw a line about 1" long on the main body tube at each of the printed fin positions on the shroud as shown.

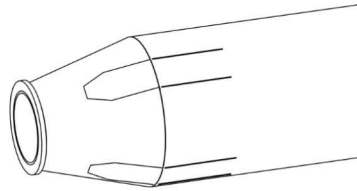

ATTACH FINS

- ❑ 22. Using the printed fin guides and the drawn lines, glue a fin assembly at each position with the fin slot toward the bottom as shown. Repeat with the other three fin assemblies. Allow to dry completely.

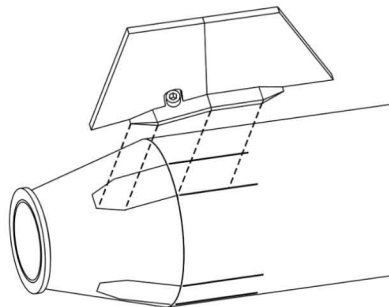

APPLY FILLETS

- ❑ 23. Run a small bead of glue along all the joints of the fin parts and each fin-body tube joint. Using your forefinger, smooth the glue into fillets. Allow this assembly to dry in a vertical position.

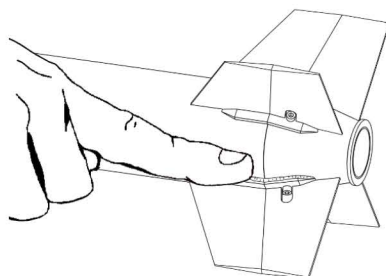

NOSE CONE

- ❑ 24. Twist the screw eye (SE-10) into the center of the nose cone. Unscrew it and squirt glue into the hole. Reinstall the screw eye and wipe off any excess glue.

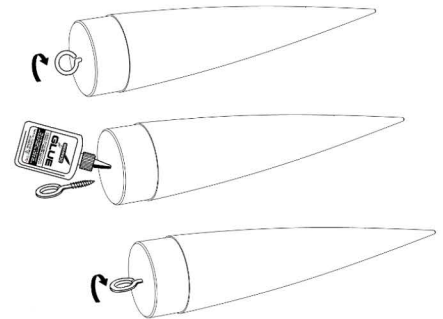

LAUNCH LUGS

- ❑ 25. Glue one of the launch lugs (LL-2AM) halfway between two fins and even with the bottom of the main body tube.

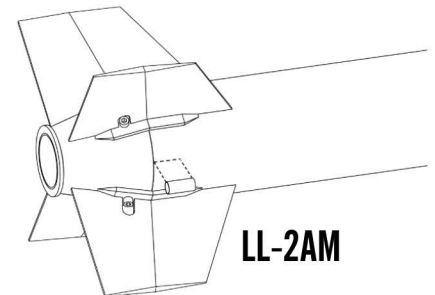

- ❑ 26. Glue the other launch lug (LL-2AM) at the joint between the two main tubes and in line with the bottom launch lug. Sight down the tube to insure the launch lug is parallel with the fins and in line with the bottom launch lug. Apply a bead of glue along the sides of both launch lugs.

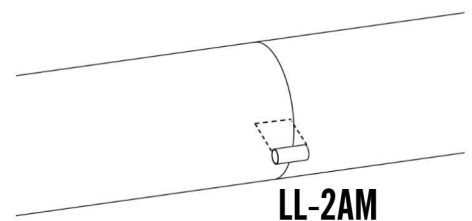

FINAL ASSEMBLY

❑ 27. Assemble the 15" chute (CP-12-24) using the instructions included with the chute. Pull the lines tight on the chute and make sure they are all of equal length. Attach the chute to the screw eye in the nose cone. Tie the free end of the elastic cord to the screw eye.

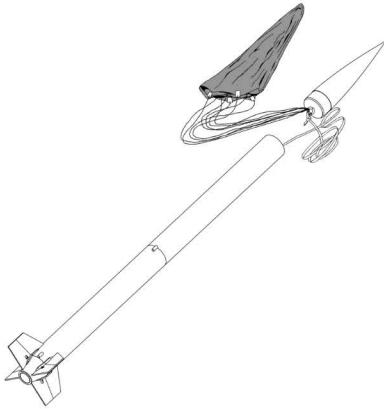

FINISHING

❑ 28. When the fillets have dried, prepare balsa surfaces for a smooth professional looking finish. Fill the wood grain with balsa fillercoat or sanding sealer. When dry, sand with fine sandpaper. Repeat until smooth.

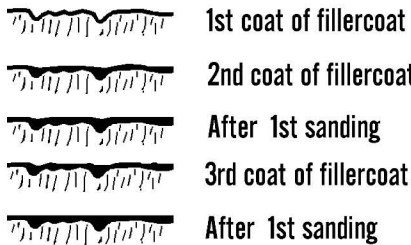

❑ 29. After all balsa surfaces have been prepared, wipe off all balsa dust with a dry cloth. First spray the model with an enamel primer. Choose high visibility colors like white and red for the final colors. The design on the front was used in many promotional models.

❑ 30. Spray painting your model with a fast-drying enamel will produce the best results. PATIENCE...is the most important ingredient. Use several thin coats, allowing each coat to completely dry before the next coat. Start each spray a few inches above the model and end a few inches below the model. Keep the can about 12" away and use quick light coats. The final coat can be a little heavier to give the model a glossy wet-looking finish.

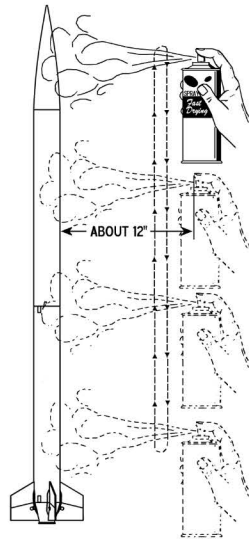

❑ 31. After the paint has dried, decals may be applied. The decals supplied with the Arcas™ are waterslide decals. Each decal should be cut separately from the sheet. Think about where you want to apply each decal and check for fit before wetting the decal. Use the cover photo for suggested placement. Dip each decal in a small dish of water that has a drop of detergent. It will take about 30 seconds before the decal is loose enough to apply.



❑ 32. Slide the decal in place and use the paper backing to work the bubble out. Repeat for all the decals. Be careful with covering decals with a clear coat. Many of the new sprays are not compatible. Future floor polish is suggested.

FLIGHT PREPPING

❑ 33. Mounting the engine: Wrap a few turns of masking tape around the engine. Test fit to make sure it is snug in the engine tube.

❑ 34. Apply a few sheets of recovery wadding in the top of the main body tube. Fold the parachute and pack it and the shock cord on top of the recovery wadding. Slide the nose cone into place, making sure it does not pinch the shock cord or parachute.

❑ 35. Refer to the model rocket engine manufacturer's instructions to complete the engine prepping. Different engines have different igniters and methods of hooking them up to the launch controllers.

❑ 36. Carefully check all parts of your rocket before each flight as a part of your pre-flight checklist. Launch the Arcas™ from a 1/8" diameter by 36" long launch rod.

❑ 37. After each flight, promptly remove the spent engine casing and dispose of properly. Clean any residue from your model for many flights.

SEMROC

ARCAS™

1/3 SCALE MODEL

Famous Sounding

Rocket made by Atlantic
Research Corporation

Ejection Baffle

**Precision Turned
Balsa Nose Cone**

**Laser Cut
Balsa Fins**

**Water Slide
Decal**

**15" Parachute
Recovery**

*Design by
Carl McLawhorn*

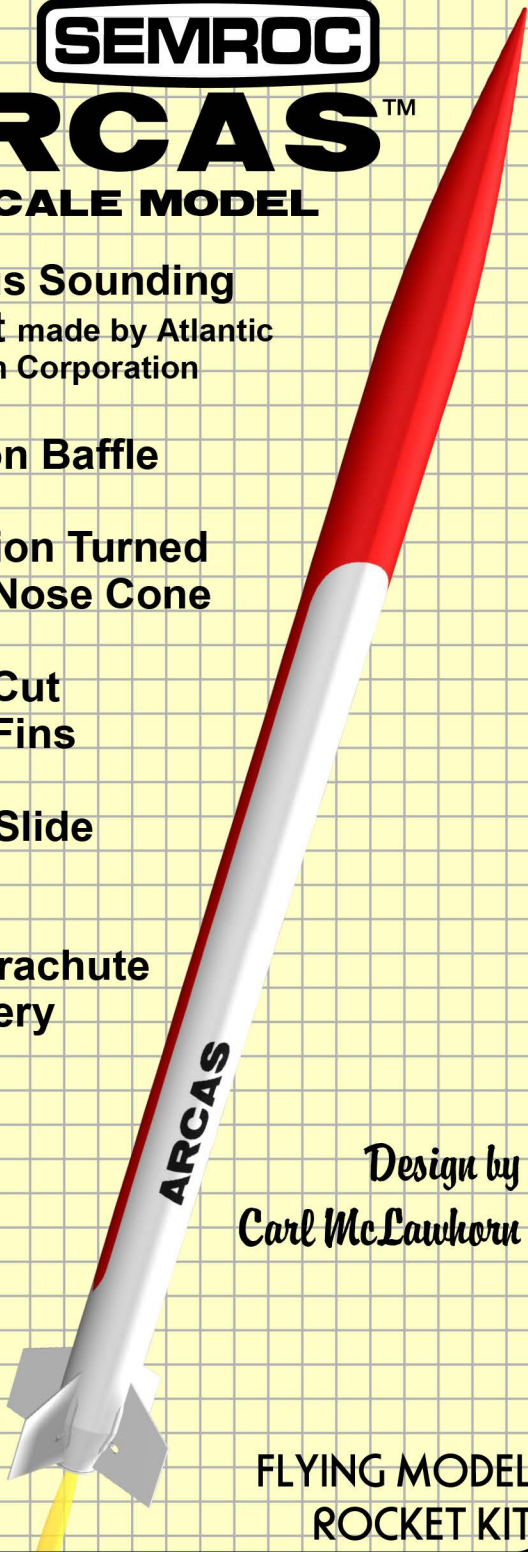

**FLYING MODEL
ROCKET KIT**

Made in the U.S.A by Semroc - Dayton, Ohio

**ARCAS™
Kit No. KS-8**

Specifications	Engine	Approx. Altitude
Body Diameter 1.54" (3.9 cm)	B6-4	250'
Length 30.4" (77.2 cm)	C6-5	600'
Fin Span 5.0" (12.7 cm)	D16-5	1200'
Net Weight 2.4 oz. (68.1 g)		

Skill Level 2