



About Centuri Engineering

Centuri Engineering Company was started in 1961 by Leroy (Lee) Piester in his garage while he was still in college in Phoenix, Arizona. With his wife, Betty, they built Centuri into one of the largest model rocket companies ever.

Centuri was known for its unusual and innovative designs, producing over 140 different kits with something for every model rocketeer. They also produced model rocket engines and pioneered the modern composite high powered engines with their Enerjet line.

Centuri Engineering was sold to Damon in the late 1960's and shared the same parent corporation with Estes Industries, the largest model rocket company in the world. The Centuri product line was kept separate from the Estes line until 1983. A few of the old kits have been reissued by Estes since then, but for the most part, Centuri Engineering Company lives today only in the dreams of the senior members of the model rocket community.

About the Magnum Hornet™

The original Magnum Hornet was released in the final days that Centuri Engineering was kept as a separate product line once they were bought by Damon. It was one of the few Centuri models that was released with exclusive Estes parts. It only had a three year production run. It was released as #5341 and retailed for \$4.00.

The Semroc Retro-Repro™ Magnum Hornet™ is very close to the original. The die-cut fins are replaced with more accurate laser-cut fins. The blow molded PNC-55AC plastic nose cone that was used on the later Cherokee-D is replaced with a balsa equivalent. The woefully small streamer on the original is replaced with a parachute. The original rubber shock cord is replaced with an elastic cord for longer life along with a Kevlar® cord for greater reliability.

What is a Retro-Repro?

A Retro-Repro™ is a retro reproduction of an out-of-production model rocket kit. It is a close approximation of a full scale model of an early historically significant model rocket kit from one of the many companies that pioneered the hobby over the past half century. A Retro-Repro™ is not a true clone or identical copy of the original. It incorporates improvements using modern technology, while keeping the flavor and build appeal of the early kits.

March 13, 2009, August 14, 2015

Copyright © 2009 Semroc
www.semroc.com

SEMROC

**MAGNUM™
HORNET**

**D-Powered Magnum
Series High Performance**

**1980 Retro
Reproduction**

**Precision Turned
Balsa Nose Cone**

**Laser Cut Balsa
Fins**

**Includes Adapter
For 18mm
Motors**

**Water Slide
Decals**

**12" Parachute
Recovery**

MADE IN THE
USA

SEMROC

FLYING
MODEL
ROCKET KIT

Made in the U.S.A by Semroc - Dayton, Ohio

Magnum Hornet™ Kit No. KV-69

Specifications	Engine	Approx. Altitude
Body Diameter 1.325" (3.4 cm)	A8-3	130'
Length 19.6" (60.5 cm)	B6-4	375'
Fin Span 5.7" (14.5 cm)	C6-5	850'
Net Weight 1.7 oz. (48.2 g)	D12-7	1350'

Skill Level 1

Parts List

EXPLODED VIEW

- A 1 Balsa Nose Cone... BNC-55AC
- B 1 Body Tube..... BT-55C
- C 1 Body Tube..... BT-50J
- D 1 Laser Cut Fins FV-69
- E 1 Ring Set RAH-5055S
- F 1 Screw Eye SE-10
- G 1 Engine Hook EH-28
- H 1 Elastic Cord..... EC-124
- I 1 Kevlar® Thread..... SCK-18
- J 1 Launch Lug LL-330
- K 1 Adapter Ring..... AR-2050
- L 1 Chute Pak..... CP-12-24
- M 1 Decal DKV-69

Included in D-Convertor Mount

- N 1 Body Tube..... BT-20J
- O 2 Adapter Rings AR-2050
- P 1 Split Ring AR-2050S
- Q 1 Engine Block EB-20A
- R 1 Engine Hook EH-28

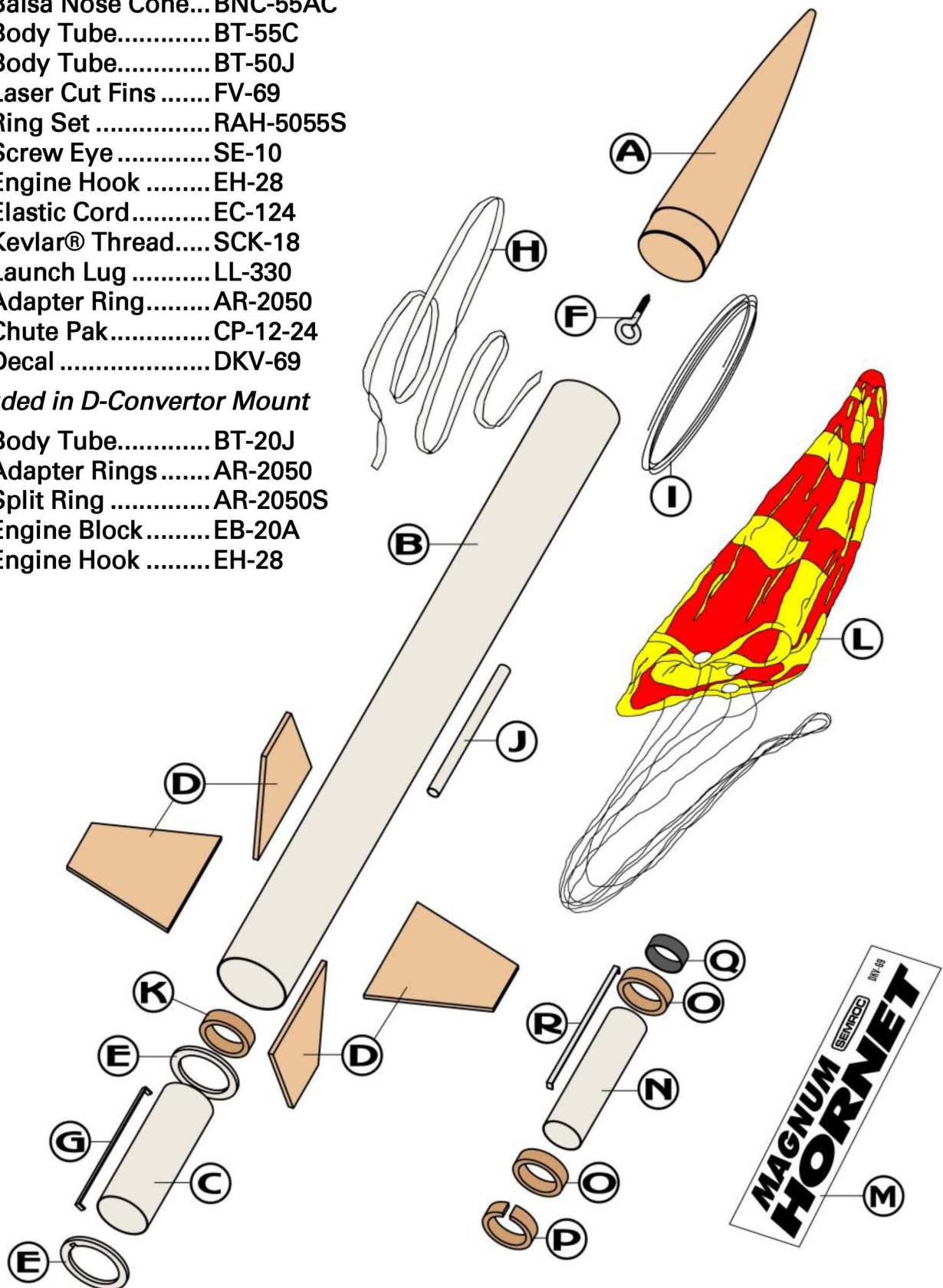

BEFORE YOU START!

Make sure you have all the parts included in this kit that are listed in the Parts List in the center of these instructions. In addition to the parts included in this kit, you will also need the tools and materials listed below. Read the entire instructions before beginning to assemble your rocket. When you are thoroughly familiar with these instructions, begin construction. Read each step and study the accompanying drawings. Check off each step as it is completed. In each step, test-fit the parts together before applying any glue. It is sometimes necessary to sand lightly or build-up some parts to obtain a precision fit. If you are uncertain of the location of some parts, refer to the exploded view in the center of these instructions. It is important that you always ensure that you have adequate glue joints.

TOOLS

In addition to the parts supplied, you will need the following tools to assemble and finish this kit.



ASSEMBLY

- 1. These instructions are presented in a logical order to help you put your Magnum Hornet™ together quickly and efficiently. Check off each step as you complete it and we hope you enjoy putting this kit together.

FIN PREPARATION

- 2. Lightly sand each side of the laser-cut fins (FV-69.) Carefully push the laser-cut fins from their sheet. Start at one point on each fin and slowly and gently work around the fin.



- 3. Stack all the fins in a set. Line the set of fins up squarely and sand the fins back and forth over some fine sandpaper to get rid of the hold-in tabs as shown below.

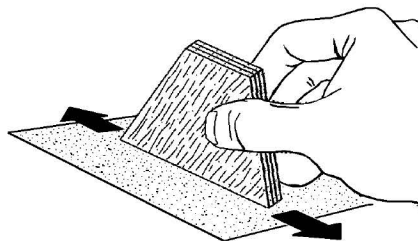

- 4. Round the leading and trailing edges of each fin. Leave the tip and root edges flat. Repeat for all four fins. The trailing edge can be sanded to a bevel for a more aerodynamic shape.

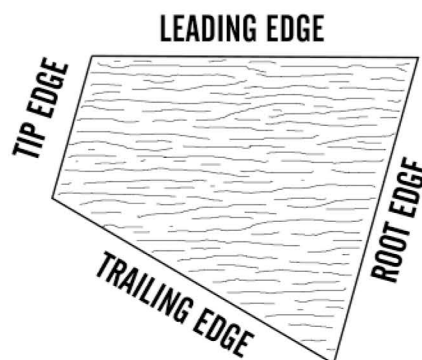

ENGINE MOUNT

- 5. Bend both of the engine hooks (EH-28) slightly so they form a slight bow in the direction shown.

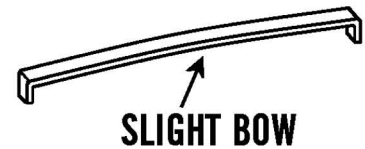

- 6. Place a mark 1/4" from one end of the largest engine tube (BT-50J).



- 7. Using a hobby knife, punch a small slit at the marked line.

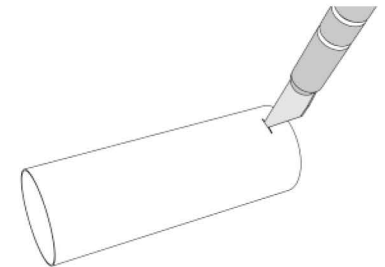

- 8. Tie a loop in one end of the yellow Kevlar® cord (SCK-18). Insert one end of the engine hook through the loop and into the punched slit.

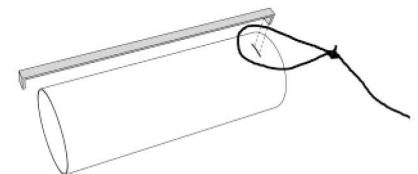

- 9. Carefully punch out the two fiber rings (RA-5055S). Align the ring without the slot over the engine hook and slide it against the Kevlar® cord from the bottom.

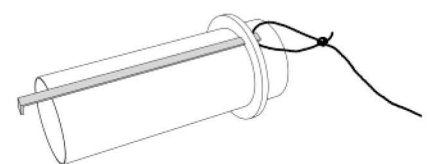

- ❑ **10.** Wrap a strip of masking tape around the center of the engine tube. Apply a film of glue over the masking tape and on the exposed section of the engine hook towards the front ring and by the Kevlar® cord attachment point. Keep glue off the engine hook near the overhang end.

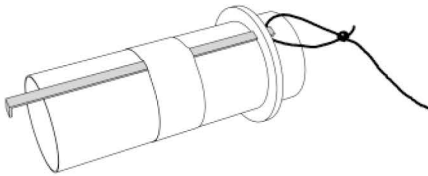

- ❑ **11.** Slide the other centering ring (with large slot) over the engine hook and engine tube until it is 1/4" from the bottom of the engine tube. Run a fillet of glue around each side of both of the rings. Keep glue out of the slot. Allow the glue to dry while checking for runs. Make sure the glue does not get on the outer edge.

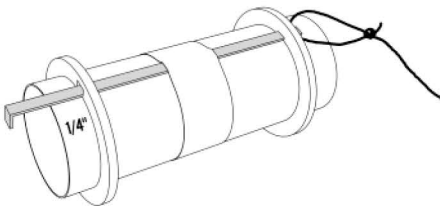

- ❑ **12.** Glue the thrust ring (AR-2050) against the top of the engine hook. After the ring is in place, run a bead of glue around the inside of the ring to protect it from the ejection gases.

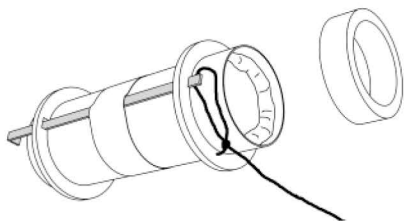

- ❑ **13.** Tuck the Kevlar® cord into the engine tube to keep it out of the way until it is needed later.

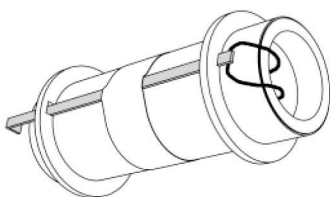

MARK TUBE

- ❑ **14.** Stand the large body tube (BT-55C) on the fin guide below and make the fin position marks on the sides of the tube. Find a convenient channel or groove such as a partially open drawer, a door jamb (as shown,) or a piece of molding. Using the channel, extend the marks the full length of the tube to provide lines for aligning the fins.

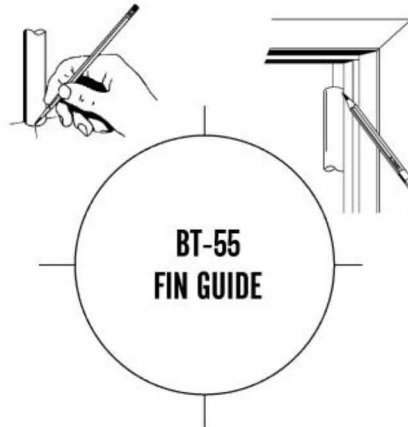

ATTACH MOUNT

- ❑ **15.** Apply a thick bead of glue inside the aft end of the main body tube and on the top side of the bottom ring, keeping glue away from the slot. Insert the engine mount assembly with the thrust ring end first into the main body tube until the bottom ring is just inside the main tube. Do not stop until it is in the correct place. Allow to dry completely in a vertical position.

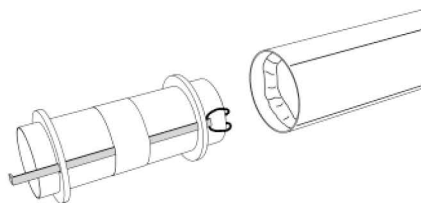

ATTACH FINS

- ❑ **16.** Apply glue to the root edge of one of the fins and position it along one of the lines drawn for the fins on the side of the body tube and even from the bottom. Remove the fin, set it aside and allow it to almost dry, apply additional glue, and reposition.

Repeat for the other three fins. If you follow these instructions, the fins will not require much additional work to keep them aligned. Allow the fins to completely dry, checking carefully to make sure they are parallel with the main body tube.

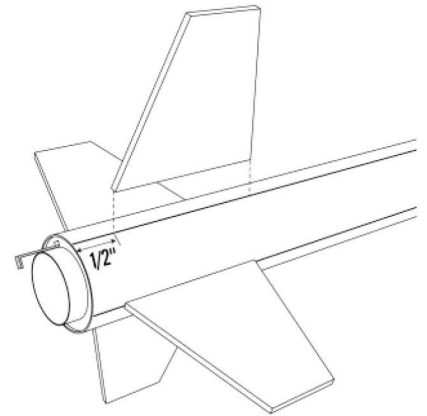

LAUNCH LUG

- ❑ **17.** Apply a bead of glue to the launch lug (LL-330) and apply it to the main body tube, centered between two fins and 3" from the bottom. Sight from one end to make sure it is parallel with the fins.

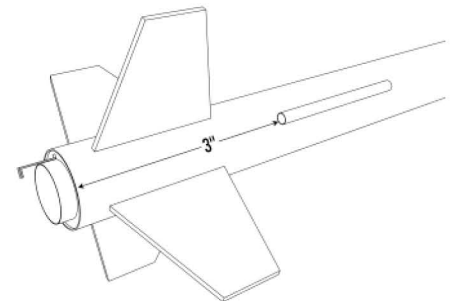

APPLY FILLETS

- ❑ **18.** After the fin assembly is completely dry, run a small bead of glue along both sides of each fin-body tube joint. Using your forefinger, smooth the glue into fillets. Apply a fillet of glue on each side of the launch lug. Allow this assembly to dry in a vertical position.

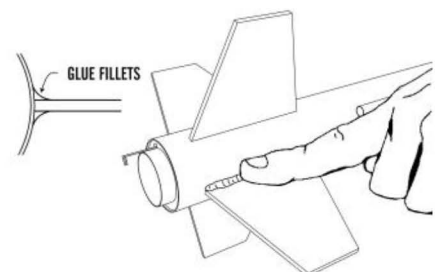

NOSE CONE

- ❑ 19. Insert the nose cone in the body tube and check for proper fit. The nose cone should be snug to hold itself in alignment. If it is too loose, add masking tape. If it is too tight, sand the shoulder slightly.

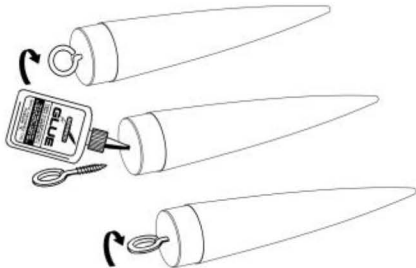

CONVERTER

NOTE. Although the Magnum's are designed for D-power, each kit is provided with an 18 mm converter to fly it on small fields with lower power. When completed, this converter is the same size as a standard D-power engine. When using it, insert a standard 18 mm engine and make sure the engine hook is securely locked on the end of the engine. Insert this assembly into the rocket and make sure the engine hook in the rocket secures the D-Converter.

- ❑ 20. Place a mark 1/4" from one end of the small engine tube (BT-20J). Place another mark 1-3/8" from either end.

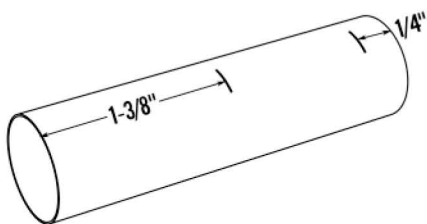

- ❑ 21. Using a hobby knife, punch a small slit at the 1/4" marked line.

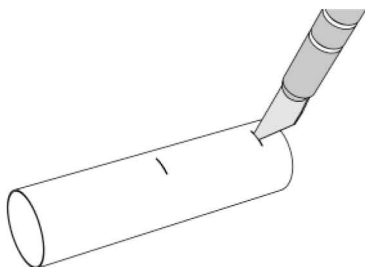

- ❑ 22. Insert one end of the engine hook (EH-28) into the punched slit.

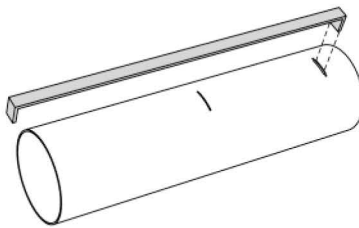

- ❑ 23. Slide the split ring (AR-2050S) over the bottom end of the engine tube. Align it even with the end and centered around the engine hook. Do not glue yet.

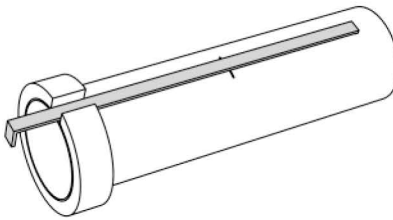

- ❑ 24. Slide one of the centering rings (AR-2050) over the top of the tube and even with the 1-3/8" mark.

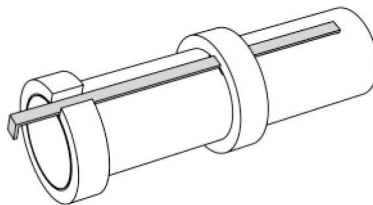

- ❑ 25. Slide the remaining centering ring (AR-2050) over the top of the tube and even with the top of the tube.

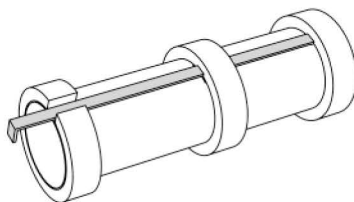

- ❑ 26. Glue the engine block (EB-20A) against the top of the engine hook and even with the engine tube. After the ring is in place, run a bead of glue around the inside of the ring to protect it from the ejection gases.

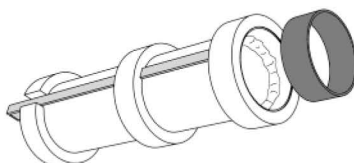

- ❑ 27. Check the alignment of all the centering rings and apply a bead of glue around each joint. Be sure to keep all glue off the outer edge of the rings!

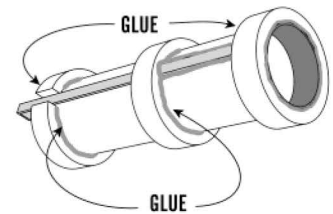

FINAL ASSEMBLY

- ❑ 28. Using a pencil or dowel, push the Kevlar cord out through the top of the main body tube. Tie the free end of the Kevlar® cord to one end of the elastic cord (EC-124) using an overhand knot.

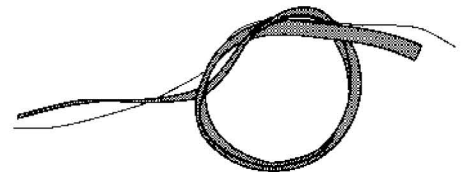

- ❑ 29. Assemble the 12" chute (CP-12-24) using instructions to make a 12" Parachute. Pull the lines tight on the chute and make sure they are all of equal length. Attach the chute by tying them to the screw eye. Put a drop of glue on the joint to keep the lines from moving. Attach the free end of the elastic cord to the screw eye. Put a drop of glue on that joint as well.

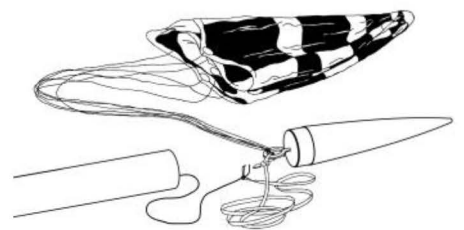

This completes the
assembly of your

MAGNUM HORNET

FINISHING

30. When the fillets have dried, prepare balsa surfaces for a smooth professional looking finish. Fill the wood grain with balsa fillercoat or sanding sealer. When dry, sand with fine sandpaper. Repeat until smooth.



1st coat of fillercoat



2nd coat of fillercoat



After 1st sanding



3rd coat of fillercoat



After final sanding

31. After all balsa surfaces have been prepared, wipe off all balsa dust with a dry cloth. First spray the model with an enamel primer. Choose a high visibility color like white for the final color.

32. Spray painting your model with a fast-drying enamel will produce the best results. PATIENCE...is the most important ingredient. Use several thin coats, allowing each coat to completely dry before the next coat. Start each spray a few inches above the model and end a few inches below the model. Keep the can about 12" away and use quick light coats. The final coat can be a little heavier to give the model a glossy wet-looking finish.

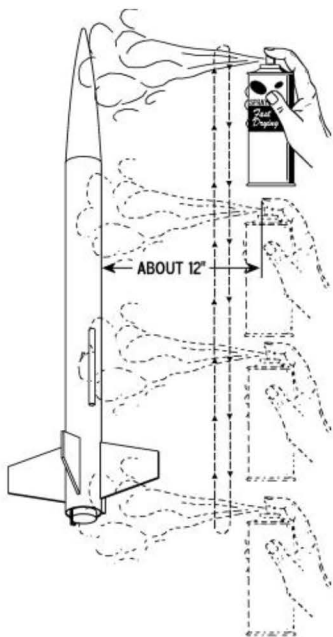

33. After the paint has dried, decals should be applied. The decals supplied with the Magnum Hornet™ are waterslide decals. Each decal should be cut separately from the sheet. Think about where you want to apply each decal and check for fit before wetting the decal. Use the cover photo for suggested placement. Dip each decal in a small dish of water that has a drop of detergent. It will take about 30 seconds before the decal is loose enough to apply.



34. Slide the decal in place and use the paper backing to work the bubble out. Repeat for all the decals.

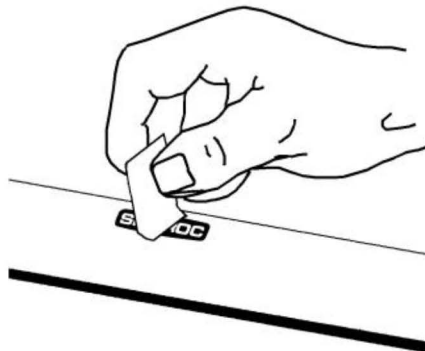

37. Refer to the model rocket engine manufacturer's instructions to complete the engine prepping. Different engines have different igniters and methods of hooking them up to the launch controllers.

38. Carefully check all parts of your rocket before each flight as a part of your pre-flight checklist. Launch the Magnum Hornet™ from a 3/16" diameter by 36" long launch rod. For smaller than D-power, a standard 1/8" x 36" rod may be used.

39. After each flight, promptly remove the spent engine casing and dispose of properly.

FLIGHT PREPPING

35. Mounting the engine: Insert the engine and make sure the engine hook keeps the engine in snugly. The hook may be slightly bent to make sure the engine is retained.

36. Apply a few sheets of recovery wadding in the top of the main body tube. Fold the parachute and pack it and the shock cord on top of the recovery wadding. Slide the nose cone into place, making sure it does not pinch the shock cord or parachute.

SEMROC

MAGNUM™ HORNET

**D-Powered Magnum
Series High Performance**

**1980 Retro
Reproduction**

**Precision Turned
Balsa Nose Cone**

**Laser Cut Balsa
Fins**

**Includes Adapter
For 18mm
Motors**

**Water Slide
Decals**

**12" Parachute
Recovery**



FLYING
MODEL
ROCKET KIT

Made in the U.S.A by Semroc - Dayton, Ohio

Magnum Hornet™

Kit No. KV-69

Specifications	Engine	Approx. Altitude
Body Diameter 1.325" (3.4 cm)	A8-3	130'
Length 19.6" (60.5 cm)	B6-4	375'
Fin Span 5.7" (14.5 cm)	C6-5	850'
Net Weight 1.7 oz. (48.2 g)	D12-7	1350'

Skill Level 1