



## About Semroc

Semroc Astronautics Corporation was started by Carl McLawhorn in his college dorm at North Carolina State University in November, 1967. Convincing a small group of investors in his home town of Ayden, North Carolina to invest in a small corporation, the company was re-incorporated as Semroc Astronautics Corporation on December 31, 1969.

Semroc produced a full line of model rocket kits and motors. At its peak, Semroc had twenty-five full time employees working at two facilities. One was for research and development, printing, shipping, and administration. The other was outside of town and handled all production and model rocket motor manufacturing. For several years, Semroc successfully sold model rocket kits, supplies, and motors by mail-order and in hobby shops. In early 1971, Semroc became insolvent and had to close its doors.

After 31 years of dreams and preparations, Semroc Astronautics Corporation was reincorporated on April 2, 2002 with a strong commitment to helping put the fun back into model rocketry. Many years of excellent service to the rocketry community passed by until sadly, on August 11 2013, Carl passed away and left a great void in the hearts of many rocketeers. He is forever in our hearts and minds.

In February of 2015, Semroc was sold to eRockets and moved to Dayton, Ohio where it resides today. It is our goal to continue the level of service and dedication to the hobby that Carl and his family were so well known for. We strive to serve you, our customers, to the best of our abilities as we carry the vision of Carl McLawhorn boldly into the future.

## About the Semroc Farside-X™

The Astron Farside X was first offered by Estes in 1964. Its final appearance was in the 1971 catalog. Semroc is proud to bring this Bill Simon design back to life for the modern rocketeer. We hope you enjoy many hours of building and flying fun.

July 2017

Copyright © 2017 Semroc  
www.semroc.com

# SEMROC

## FARSIDE X™

### 1964 Retro Reproduction

### Amazing 3 Stage Flights!

### Precision Turned Balsa Nosecone

### Laser Cut Balsa Fins

### Payload Bay

### Waterslide Decals

### 18" Parachute Recovery



FLYING  
MODEL  
ROCKET KIT

Made in the U.S.A by Semroc - Dayton, Ohio

### Farside-X™ Kit KV-95

Specifications		Engines	Approx. Altitude
Body Diameter	1.637	C6-7, C6-0, C6-0	2000'
Length	25"	B6-6, B6-0, B6-0	1100'
Fin Span	7"		
Net Weight	2.5 oz		

## Skill Level 3

## BEFORE YOU START!

Make sure you have all the parts included in this kit that are listed in the Parts List in these instructions. In addition to the parts included in this kit, you will also need the tools and materials listed below. Read the entire instructions before beginning to assemble your rocket. When you are thoroughly familiar with these instructions, begin construction. Read each step and study the accompanying drawings. Check off each step as it is completed. In each step, test-fit the parts together before applying any glue. It is sometimes necessary to sand lightly or build-up some parts to obtain a precision fit. If you are uncertain of the identity of some parts, refer to the exploded view. It is important that you always ensure that you have adequate glue joints.

## TOOLS

In addition to the parts supplied, you will need the following tools to assemble and finish this kit.



Super Glue



White Glue or Wood Glue



Spray Paint



Balsa Fillercoat or Sanding Sealer



Fine Sandpaper 320 to 600 grit



Hobby Knife



Ruler



Pencil



Scissors



Masking Tape



Cellophane Tape

## ASSEMBLY

- ❑ 1. These instructions are presented in a logical order to help you assemble your Semroc Farside X™ quickly and efficiently. Check off each step as you complete it. Enjoy putting this kit together.

## PAYLOAD ASSEMBLY

- ❑ 2. Twist the screw eye (N) into the center of the smaller end of the adapter (C). Unscrew it and squirt glue into the hole. Reinstall the screw eye and wipe off any excess glue.

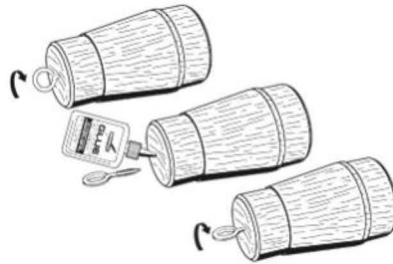

- ❑ 3. Test fit the adapter into the payload tube (D). Next, spread a small amount of glue on the inside of the payload tube. Insert the adapter until it seats even with the shoulder. Allow to dry.

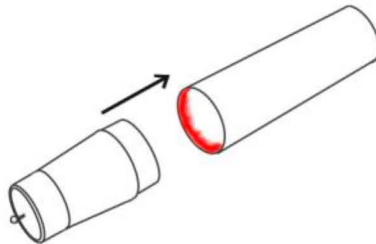

- ❑ 4. Insert the nosecone (B) into the payload tube and check for fit. Make sure it fits tightly. If a payload is added, screws (not included) or external tape may be required to secure the nose cone in flight.

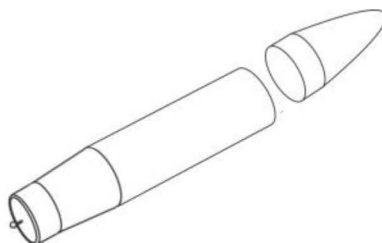

## MOTOR MOUNTS

- ❑ 5. Take 3 couplers (F) and glue an adapter ring (L) to both ends of each one. Do this by running a line of glue around the edge of the coupler and then pressing the ring into place. Wipe away any excess glue.

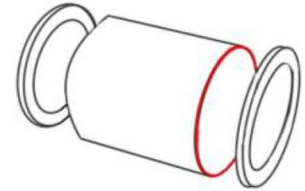

- ❑ 6. Glue the motor block (O) into the end of the 2 3/4 inch long motor mount tube (H). Smear a line of glue inside the tube, then insert the motor block and press the tube against the table until the block is even with the end of the tube.

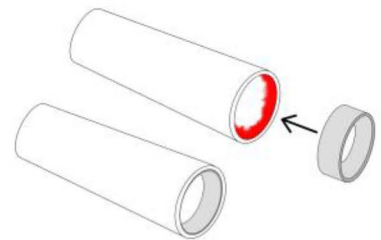

- ❑ 7. Make a mark on the 2 3/4 inch long motor mount tube 1 inch from the end without the motor block. Take an assembled coupler-ring unit from step 5 and slide it on until one ring is even with the 1 inch mark. Apply a fillet of glue around both joints. Wipe away any excess glue and set this assembly aside.

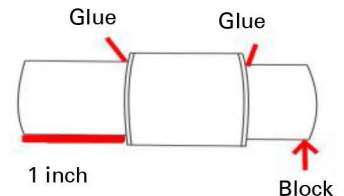

- ❑ 8. Mark the two 2 1/4 long motor tubes (G) 1/4 inch from one end. Slide an assembled coupler-ring unit up to the 1/4 inch mark on each of these two tubes, then apply a fillet of glue around the joints. Wipe away any excess glue and set both assemblies aside until completely dry.

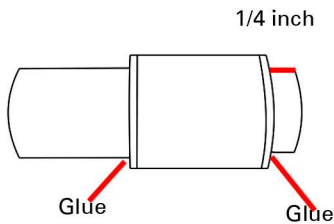

❑ **9.** Locate the Kevlar anchor (K) lightly notch the outside of the ring with a hobby knife or razor. Tie the Kevlar cord (O) in a double knot around the ring so the Kevlar is in the notch of the ring. Run a bead of glue around the top (the end with the engine block) of the centering ring of the 2 3/4 long motor mount. Slide on the notched centering ring with the attached Kevlar and press it gently into the glue. Allow time to dry.



❑ **10.** Slide the Kevlar cord into the 2 3/4 long motor tube from the top. Mark the tube 1/4 inch from the bottom end. Check the fit into the upper stage body tube, then apply a line of glue 3/4 inch inside the upper stage airframe. Slide the motor mount tube in with one smooth motion until the 1/4 inch mark on the motor mount tube is even with the end of the upper stage tube.



❑ **11.** Mark the two 2 1/4 long motor mount assemblies 1/4 inch from the end that sticks out of the assembly the farthest. Smear glue 3/4 of an inch inside one of the 2 3/4 long booster tubes (I). Slide the assembly in until the 1/4 inch mark is even with the bottom of the booster tube. Do this for both tubes.

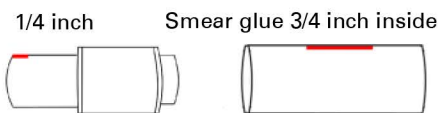

❑ **12.** Mark two couplers (F) in the middle. Smear a little glue around the inside of the top of a booster tube assembly. Slide the coupler in to the midpoint mark. Do this for both booster tube assemblies.

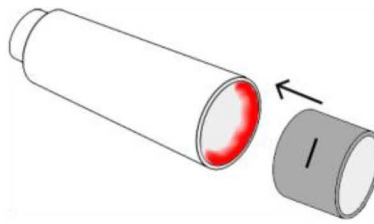

## FIN ATTACHMENT

❑ **13.** Assemble the fin alignment jig. Fold on the scored lines and glue each corner where shown with a drop of CA glue.

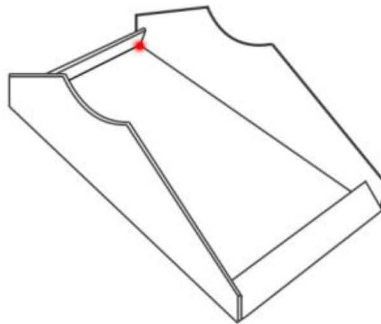

❑ **14.** Place a booster tube assembly onto the fin alignment jig. Take one first stage fin (A3) and align the trailing edge with the bottom of the booster tube. Tack in place with medium CA glue as indicated by red dots.

Repeat for all three first stage fins. After all 3 fins have been tacked in place with CA, run a bead of white glue along the root edges of the fins to form a fillet.

When all first stage fins have been attached, follow the same instructions for the second and third stage fins.

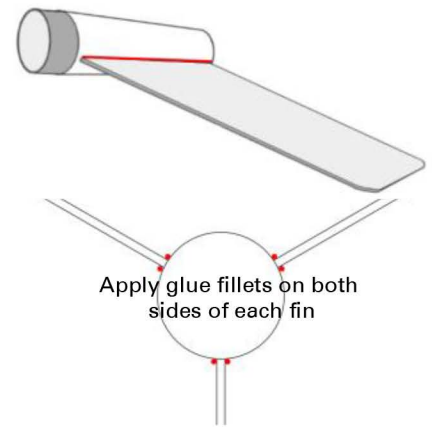
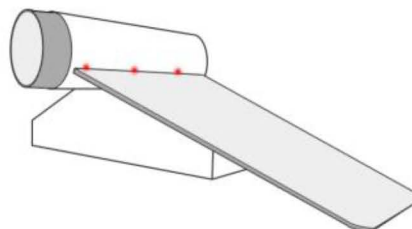

## LAUNCH LUG

❑ **15.** Glue the launch lug (J) to the launch lug standoff (M). Attach the launch lug midway between two of the second stage fins.

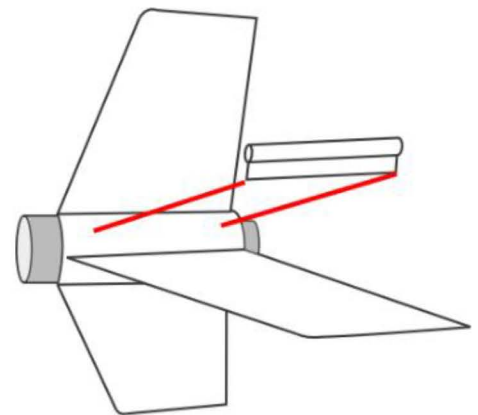

## RECOVERY

❑ **16.** Cut out the parachute on the innermost lines to form a 12 inch chute. Finish assembly according to the instructions included with the parachute.



- ❑ 16. Tie the Kevlar cord to the elastic shock cord. Pass both cords out the top of the upper stage.

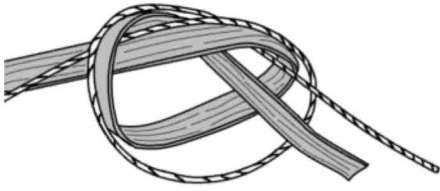

- ❑ 17. Tie the shock cord to the screw eye with a double overhand knot. Attach the parachute by passing the shroud lines through the screw eye, forming a loop and then passing the parachute canopy through the loop. Pull until snug. Set the knot with a drop of glue.

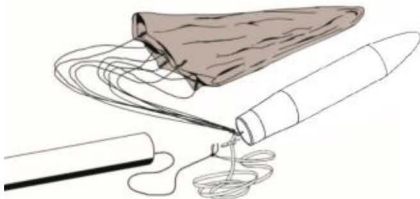

- ❑ 18. This completes the assembly of your Semroc Farside-X. The following instructions will help you prepare your rocket for a safe flight and recovery.

## STABILITY

- ❑ 19. Remove the payload section and parachute. Insert recovery wadding and replace parachute and payload section. Install an upper stage motor. Measure 7/8 of an inch down from the front edge of the body tube as shown. This is the balance point. If the payload being flown isn't heavy enough for the rocket to balance at this point, add clay until balance is achieved.



## FINISHING

- ❑ 20. When the fillets have dried, prepare balsa surfaces for a smooth professional looking finish. Fill the wood grain with balsa fillercoat or sanding sealer. When dry, sand with fine sandpaper. Repeat until smooth.



- ❑ 21. Follow the illustration on the face card to paint your Semroc Farside X. Paint the entire rocket gloss white. When the paint dries, remove the nosecone from the payload section and remove the payload section from the rocket.

Paint the nosecone gloss red.

Mask off one fin on each stage then paint the airframe of the rocket yellow.

Mask off all but one fin of each stage. Paint the three exposed fins gloss black.

## FLIGHT PREPPING

- ❑ 1. To fly, select an upper stage motor and insert it into the motor mount. If you're flying a payload, insert it now.

Check the center of gravity. The rocket should balance 7/8 of an inch behind the front of the upper stage airframe. Add clay weight to the payload as needed to accomplish this. After balance is achieved, remove the motor.

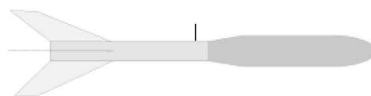

- ❑ 2. Wrap a little masking tape around the top of the upper stage motor. This motor must fit tightly into place or it will be ejected when the ejection charge fires without deploying the parachute.

- ❑ 3. Place the top of the second stage motor against the nozzle of the upper stage motor. Wrap the joint with a single layer of cellophane tape.

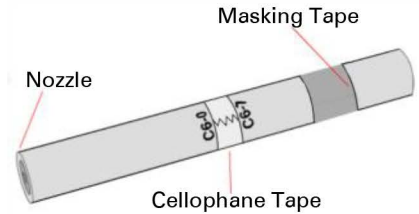

- ❑ 4. Insert the upper stage motor into the upper stage. Push it in until the top of the motor is seated against the motor block. Make sure the masking tape is holding the motor firmly in place in the upper stage.

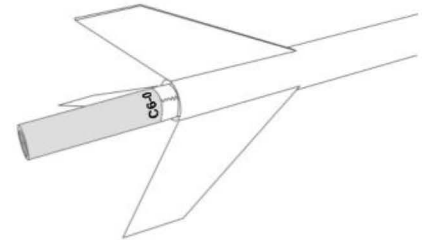

- ❑ 5. Slide the second stage onto the second stage motor.

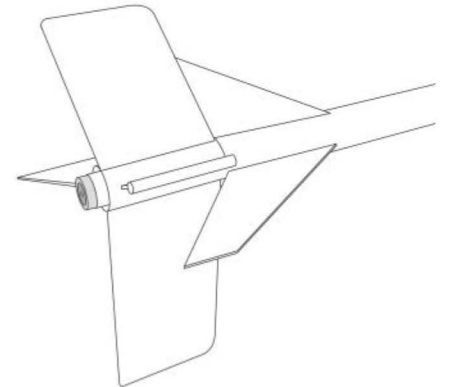

- ❑ 6. Place the top end of the first stage motor against the nozzle of the second stage motor. Wrap the joint with a single layer of cellophane tape.

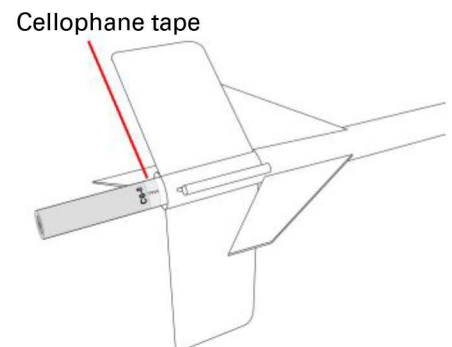

# Parts List

A1	Upper Stage Fins.....	FV-95
A2	Second Stage Fins.....	FV-95
A3	First Stage Fins.....	FV-95
B	Nosecone.....	BNC-60L
C	Adapter.....	TA-5060
D	Payload Tube.....	BT-60R
E	Upper Stage Airframe.....	BT-50H
F	Couplers (5) .....	JT-50C
G	Motor Tube 2 1/4 long (2).....	BT-20M
H	Motor Tube 2 3/4 long.....	BT-20J
I	Booster Tube 2 3/4 long (2).....	BT-50J
J	Launch Lug.....	LL-122
K	Kevlar Anchor.....	CR-20-50-1/4
L	Adapter Rings (6).....	RA-20-50
M	Launch Lug Standoff.....	FV-95
N	Screw Eye.....	SE-12
O	Motor Block.....	EB-20A
P	Parachute.....	CP-12-24
Q	Kevlar Cord.....	SCK-24
R	Elastic Cord.....	EC-124
S	Fin Alignment Jig.....	TKV-95
T	Waterslide decals.....	DKV-95

- 7. Wrap a layer of masking tape around the bottom of the second stage motor and the exposed portion of the second stage motor mount tube. Be careful to avoid overlapping the cellophane tape wrapped joint between the two motors or the stages may not separate!

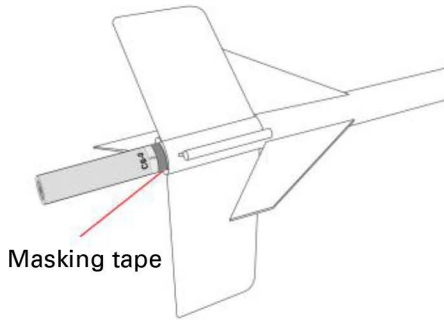

- 8. Slide on the first stage, then wrap masking tape around the bottom of the first stage motor and the exposed portion of the first stage motor mount tube.

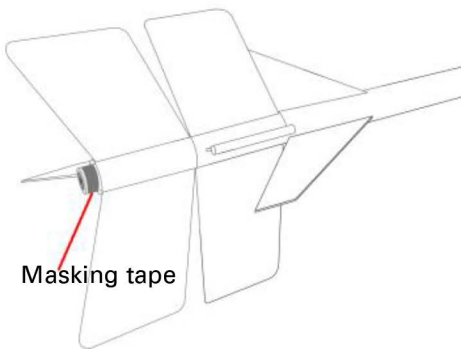

- 9. Remove the payload section and parachute. Place 4 or 5 loosely crumpled pieces of recovery wadding into the tube. Roll up the parachute and insert it, then replace the payload section.

- 10. Insert the igniter per manufacturer's instructions.

- 11. Slide the rocket onto the launch rod. Place a small standoff on the pad.

- 12. Attach the micro clips. Make sure the area is clear.

- 13. Arm the launch panel.

- 14.

5....4....3...2...1.....**LAUNCH!**

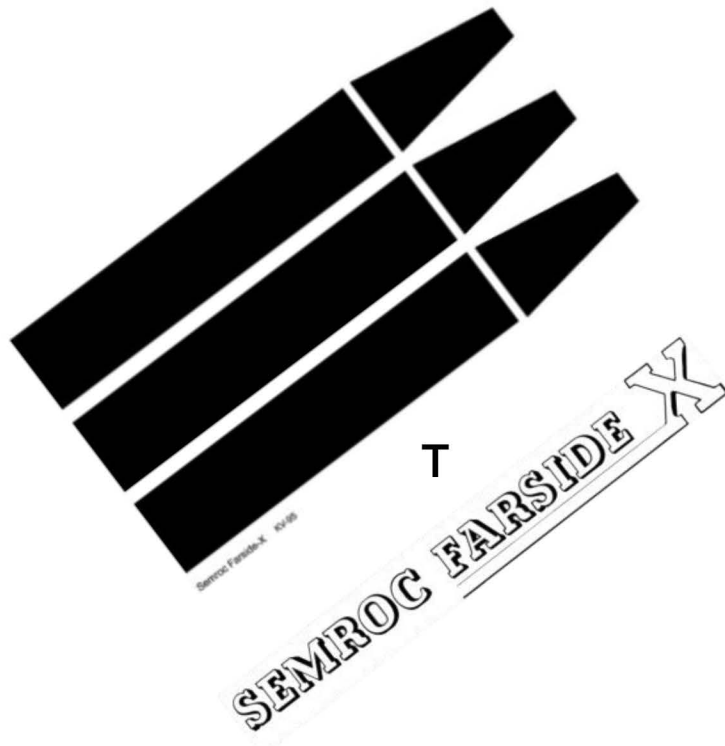

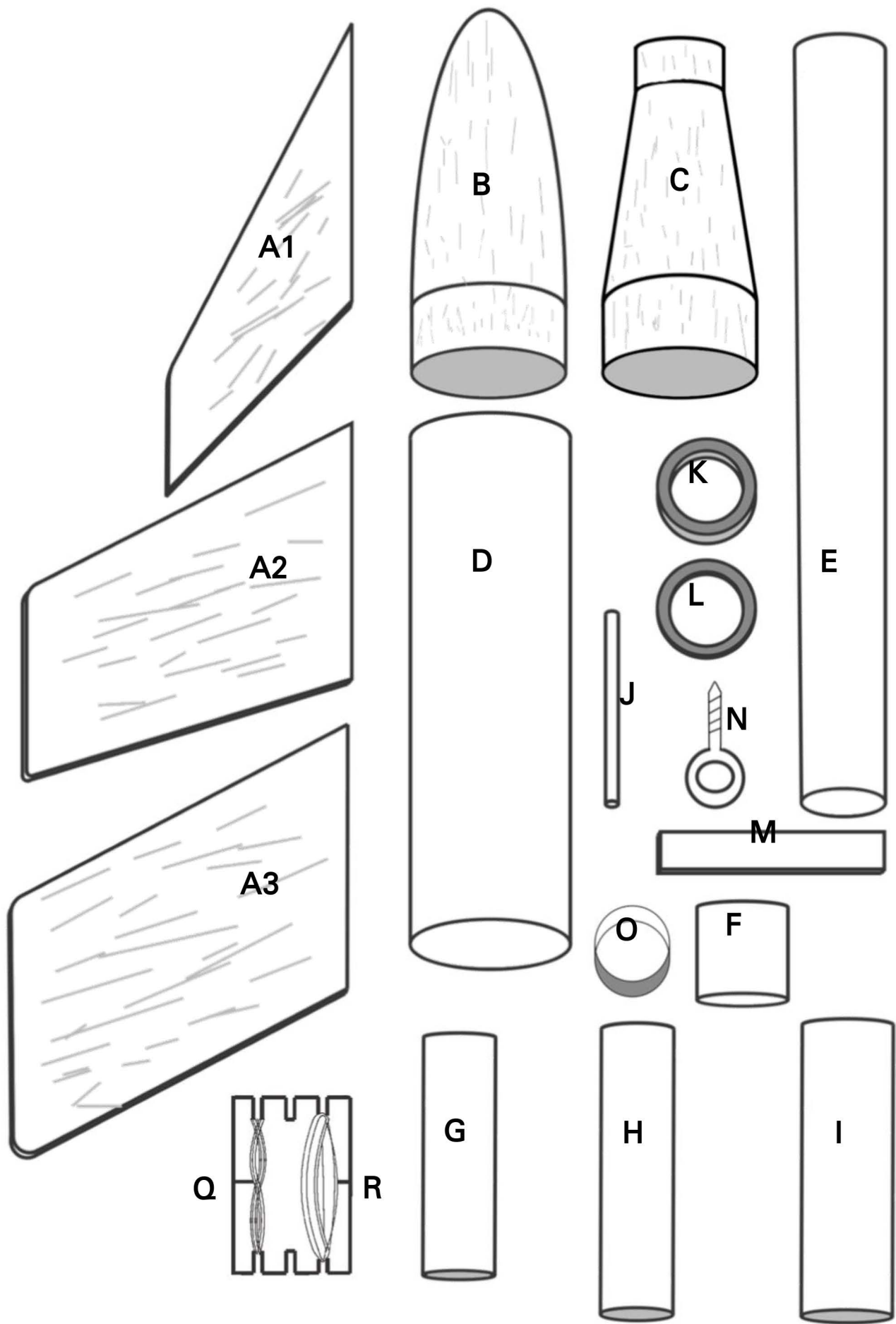

**SEMROC**

**FARSIDE X™**

**1964 Retro Reproduction**

**Amazing 3 Stage Flights!**

**Precision Turned Balsa Nosecone**

**Laser Cut Balsa Fins**

**Payload Bay**

**Waterslide Decals**

**18" Parachute Recovery**



FLYING  
MODEL  
ROCKET KIT

Made in the U.S.A by Semroc - Dayton, Ohio

**Farside-X™  
Kit KV-95**

Specifications		Engines	Approx. Altitude
Body Diameter	1.637	C6-7, C6-0, C6-0	2000'
Length	25"	B6-6, B6-0, B6-0	1100'
Fin Span	7"		
Net Weight	2.5 oz		

**Skill Level 3**