

COMET

SKILL LEVEL 1 – Recommended for Beginner Rocketeers.

BEFORE YOU START

Read all instructions before beginning work on your model. Make sure you have all parts and materials. When you are thoroughly familiar with the assembly procedure, begin construction. Check off each step as you complete it. In each step, test-fit the parts together before applying any glue. If some part doesn't fit properly, sand lightly or build up as required for precision assembly.



A DAMON COMPANY

ESTES INDUSTRIES
PENROSE, CO 81240 USA

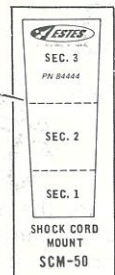
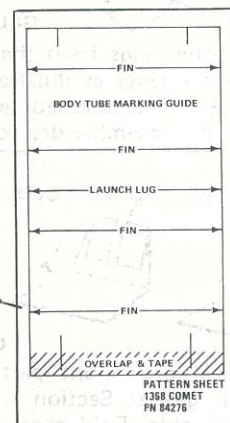
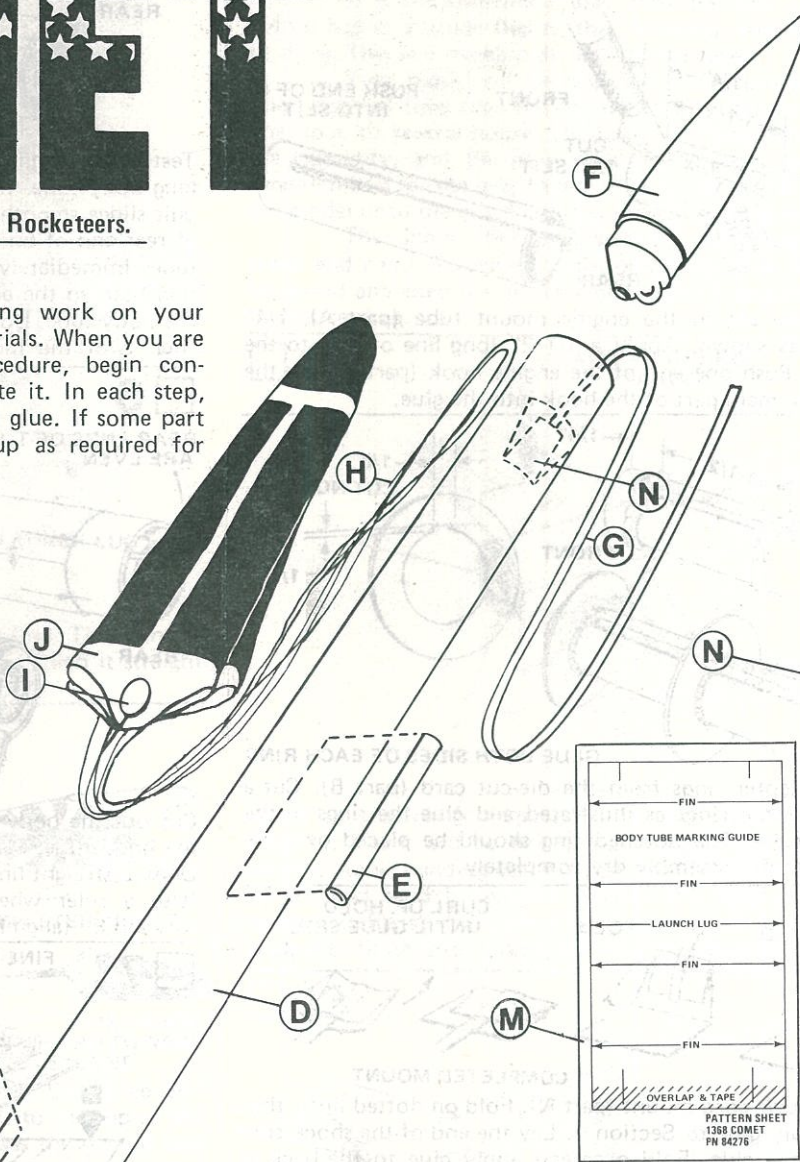
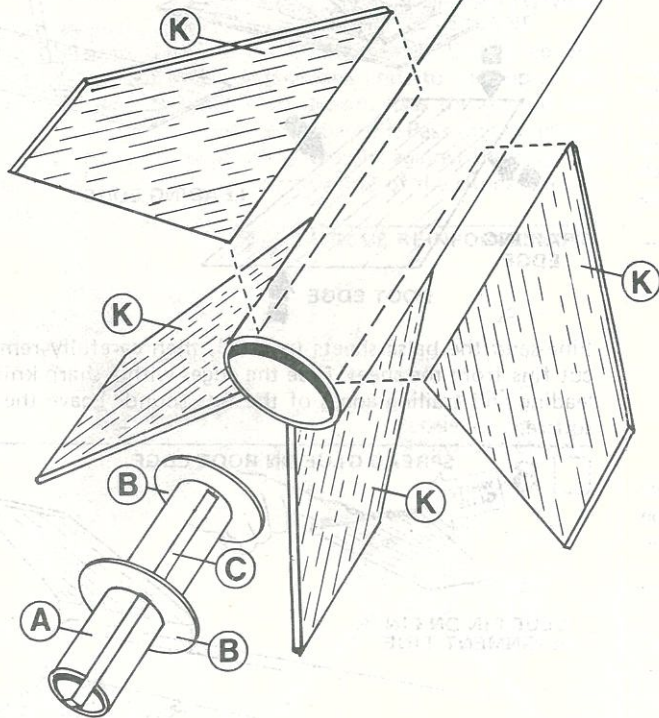

TOOLS AND MATERIALS

In addition to the parts included in this kit you will need: Scissors, white glue (Elmer's, Titebond, or similar), a modeling knife with sharp blade, pencil, ruler, sandpaper, sanding sealer, masking tape, paint brush, light blue spray enamel, and dark blue spray enamel.

For easy and positive alignment of the fins on your model, we recommend the use of Estes' Fin Alignment Guide, Part. No. 2231.

PARTS LIST KIT NO. 1368

A	1	Engine Mount Tube (type BT-20J)	30326
B	2	Adapter Rings (type RA-2055)	30126
C	1	Engine Hook (type EH-2)	35025
D	1	Body Tube (type BT-55)	30382
E	1	Launch Lug (type LL-2B)	38178
F	1	Nose Cone (type PNC-55AO)	71075
G	1	Shock Cord (type SC-1)	85730
H	1	Shroud Line (type SLT-108)	38239
I	1	Tape Disc Set (type TD-3F)	38406
J	1	Parachute (type PK-18A)	85566
K	1	Balsa Fin Sheet (type BF-78)	32239
L	1	Decal (type KD-1368)	37595
M	1	Pattern Sheet (type SP-1368)	84276
N	1	Shock Cord Mount (type SCM-50)	84444

RECOMMENDED ENGINES:
A8-3 B4-4 B6-4 B8-5
B14-5 C6-5 C6-7