



SUPER FLEA

0815A

PARTS LIST

- (A) 1 Nose Cone.....BNC-5E
- (B) 1 3" Body Tube.....BT-5CJ
- (C) 1 2" Body Tube.....BT-5BJ
- (D) 1 Shock Cord.....SC-1B
- (E) 1 Launch Lug.....LL-2A
- (F) 1 Stage Coupler.....JT-5C
- (G) 1 Fin Stock.....BFS-20B
- (H) 1 Dummy Engine.....EC-8
- (I) 1 Display Stand Card.....09014
- (J) 1 Pattern.....SP-0815
- (K) 1 Instructions.....0815A/2326-72

In addition to the materials included in your kit you will need scissors, a sharp hobby knife or single edge razor blade, sandpaper, masking tape, sanding sealer, and paint or dope. (Enamel based spray paint works best.)

WARRANTY

ESTES model rocket engines, kits, launch systems, and supplies are guaranteed against manufacturing defects. Any part or item found defective will be repaired or replaced without charge providing the defective part is returned postpaid to Estes Industries' Customer Service Department, Penrose, Colorado 81240. For fastest service, please send only the defective part.



A SUBSIDIARY OF DUNLOP
ESTES INDUSTRIES
PENROSE, COLORADO 81240

Important! Before beginning assembly of either rocket, carefully sort the kit parts according to the model in which they are used. Check each part against the parts lists. Keep the parts in two separate groups to prevent mistakes in assembling your models.

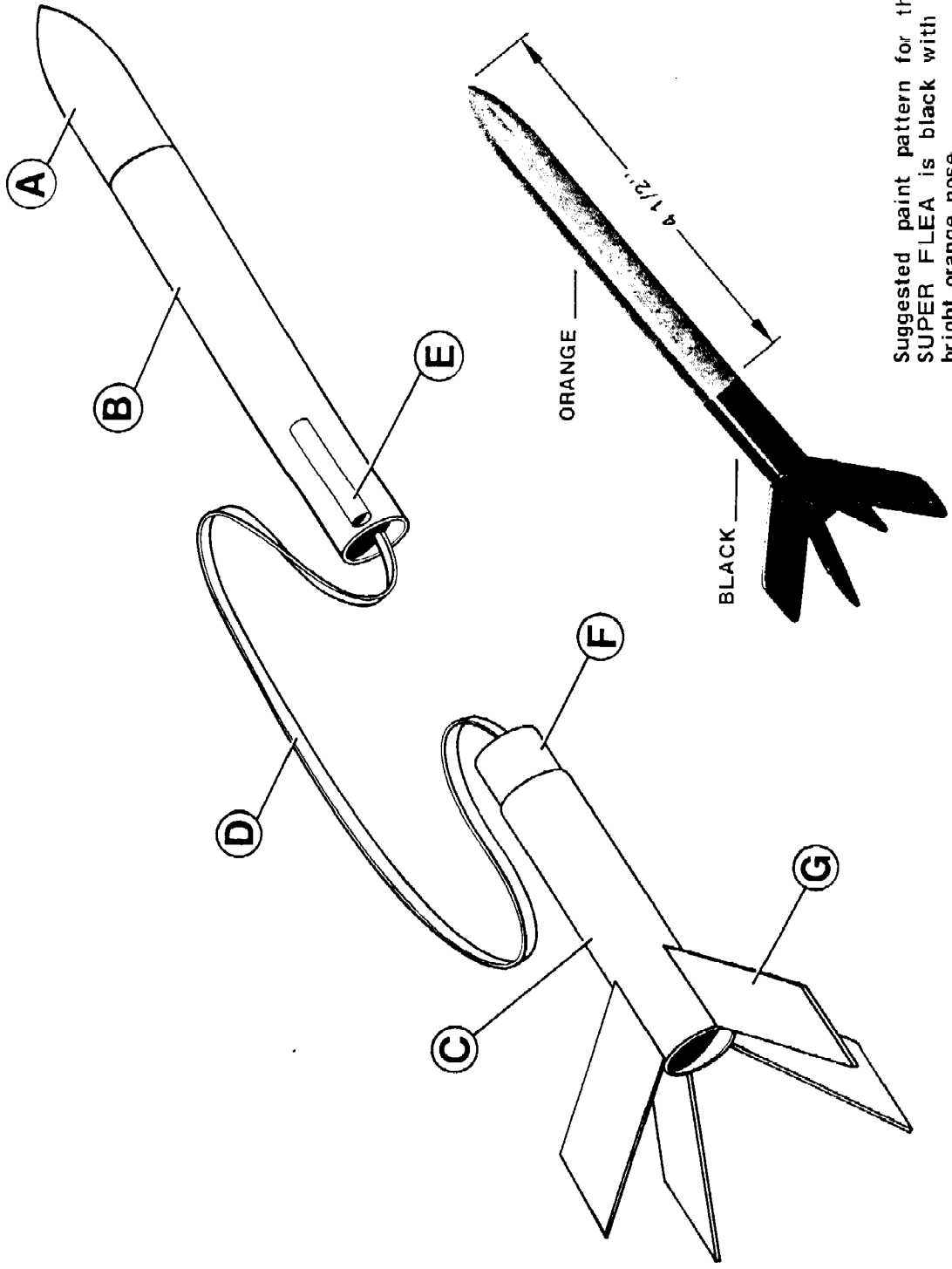

Suggested paint pattern for the SUPER FLEA is black with a bright orange nose.

ASSEMBLY INSTRUCTIONS (SUPER FLEA)

1 Wrap one end of the shock cord around the stage coupler and glue it 1/4" into the rear (2") body tube. Make sure it is straight.

2 Drop the other end of the shock cord through the forward body tube. While holding a bit of the cord wrapped around the outside, glue the nose cone into the front end of forward body tube as shown.

3 Clip the small ends of shock cord which stick out.

4 Cut out the fin pattern and use it to trace and cut out the fins.

5 Sand the leading edges, trailing edges, and tips of the fins round. Rub a thin layer of glue into the root edge.

6 Cut out the marking guide. Wrap it around the rear tube. Mark each fin location and connect matching front and rear marks with lines.

7 Glue one fin to the left of each alignment line just at the rear of the tube. After glue is dry, apply a glue fillet to both sides of each fin.

8 Glue the launch lug at the rear of the forward body tube.

9 Spray paint for best results. Use a pencil for a rocket holder. Shake can before spraying. Hold can straight up and spray in long, smooth "strokes". Shake can periodically. First coats are light, dry, mist coats. To obtain gloss, final coat should be slightly heavier.

10 Assemble the display stand according to the instructions on the back of the card.

1

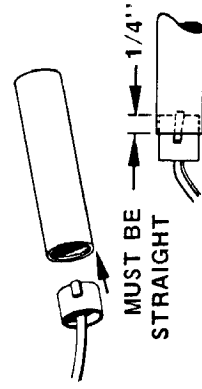

2

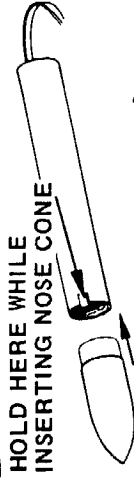

3

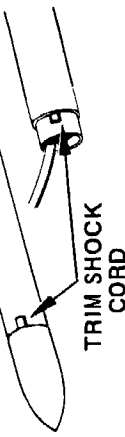

4

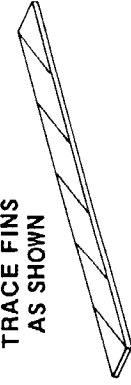

ROUND THESE EDGES

5



MARK FIN LOCATION WITH MARKING GUIDE

6

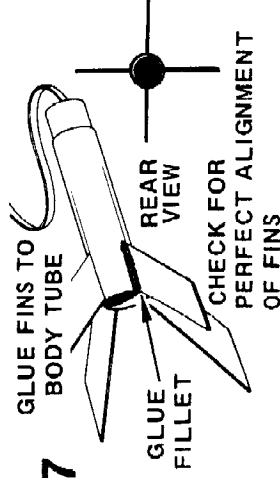
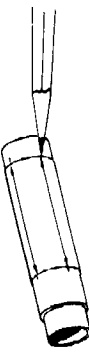

8

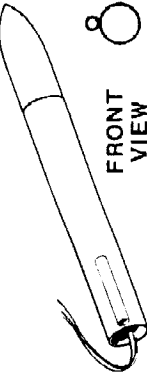

COUNTDOWN CHECKLIST

13 Select an engine. Engines recommended for use with this rocket are 1/4A3-2T, 1/2A3-2T, 1/2A3-4T, A3-4T, and A3-6T. Use 1/4A3-2T for first flight. Install an igniter as directed in the engine instructions.

12 Wrap the rear of the engine with masking tape until it fits tightly in the body tube. It must be tight for proper ejection. Insert engine all the way into the rear body section.

11 Pack 1/2 square of wadding into the stage coupler over the engine to protect the shock cord.

10 Pack the shock cord into the upper body section and slide the two sections together. Sections should come apart easily. If too tight, sand stage coupler lightly. If too loose, add small piece of masking tape to stage coupler.

9 Disarm the launch panel - remove safety key.

8 Place rocket on launch pad making sure rocket slides freely on launch rod. Clean the micro-clips and attach them to the igniter.

7 Clear the launch area, alert recovery crew and trackers. Check for low flying aircraft and unauthorized persons in the recovery area.

6 Arm the launch panel - insert safety key.

5 4 3 2 1 LAUNCH!!

MISFIRE PROCEDURE

Occasionally the igniter will heat and burn in two without igniting the engine. This is almost always caused by a failure to install it correctly. Disarm the launch panel, remove the model, clean the igniter residue from the nozzle, and install a new igniter. Follow the launching procedure again.

INSERT ENGINE INTO REAR SECTION

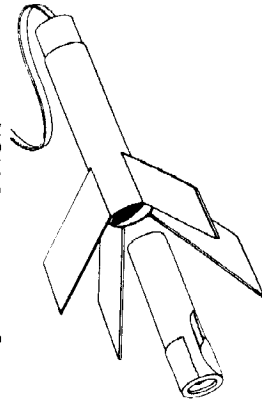

WRAP REAR OF ENGINE WITH MASKING TAPE UNTIL FITS TIGHT

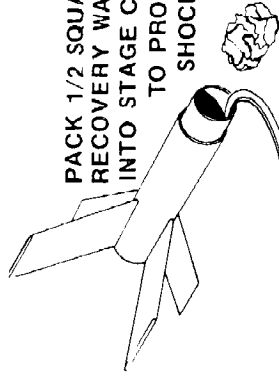

PACK 1/2 SQUARE OF RECOVERY WADDING INTO STAGE COUPLER TO PROTECT SHOCK CORD

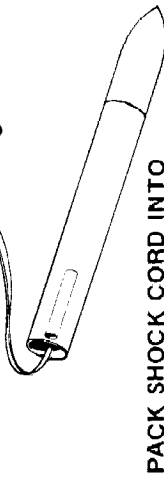

PACK SHOCK CORD INTO UPPER BODY SECTION

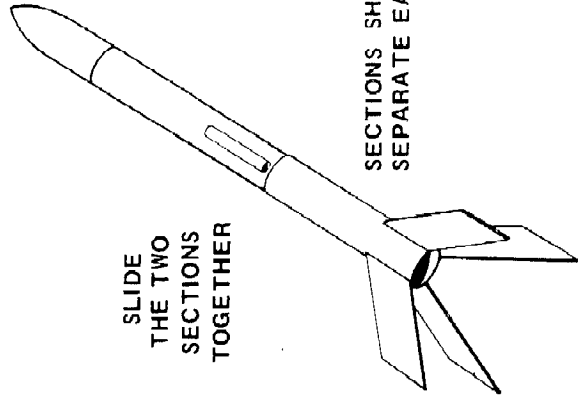

SLIDE THE TWO SECTIONS TOGETHER

SECTIONS SHOULD SEPARATE EASILY

Javelin

0815B

PARTS LIST

- (A) 1 Shock Cord.....SC-1B
- (B) 1 Stage Coupler.....JT-5C
- (C) 2 5.1" Body Tubes.....BT-5P
- (D) 1 Dummy Engine.....EC-8
- (E) 1 Engine Block.....EB-5B
- (F) 1 Fin Stock.....BFS-20A
- (G) 1 Launch Lug.....LL-2A
- (H) 1 Screw Eye.....SE-3
- (I) 1 Nose Weight.....NCW-4
- (J) 1 Nose Cone.....BNC-5AX
- (K) 1 Streamer.....SM-1A
- (L) 1 Tape Disc.....TD-1
- (M) 1 Display Stand Card.....09014
- (N) 1 Pattern.....SP-0815
- (O) 1 Instructions.....0815B/2326-72

In addition to the materials included in your kit you will need scissors, a sharp hobby knife or single edge razor blade, sandpaper, masking tape, sanding sealer, and paint or dope. (Enamel based spray paint works best.)

WARRANTY

ESTES model rocket engines, kits, launch systems, and supplies are guaranteed against manufacturing defects. Any part or item found defective will be repaired or replaced without charge providing the defective part is returned postpaid to Estes Industries' Customer Service Department, Penrose, Colorado 81240. For fastest service, please send only the defective part.

Assemble the display stand according to the instructions on the back of the card.



ESTES INDUSTRIES
PENROSE, COLO. 81240

Important! Before beginning assembly of either rocket, carefully sort the kit parts according to the model in which they are used. Check each part against the parts lists. Keep the parts in two separate groups to prevent mistakes in assembling your models.

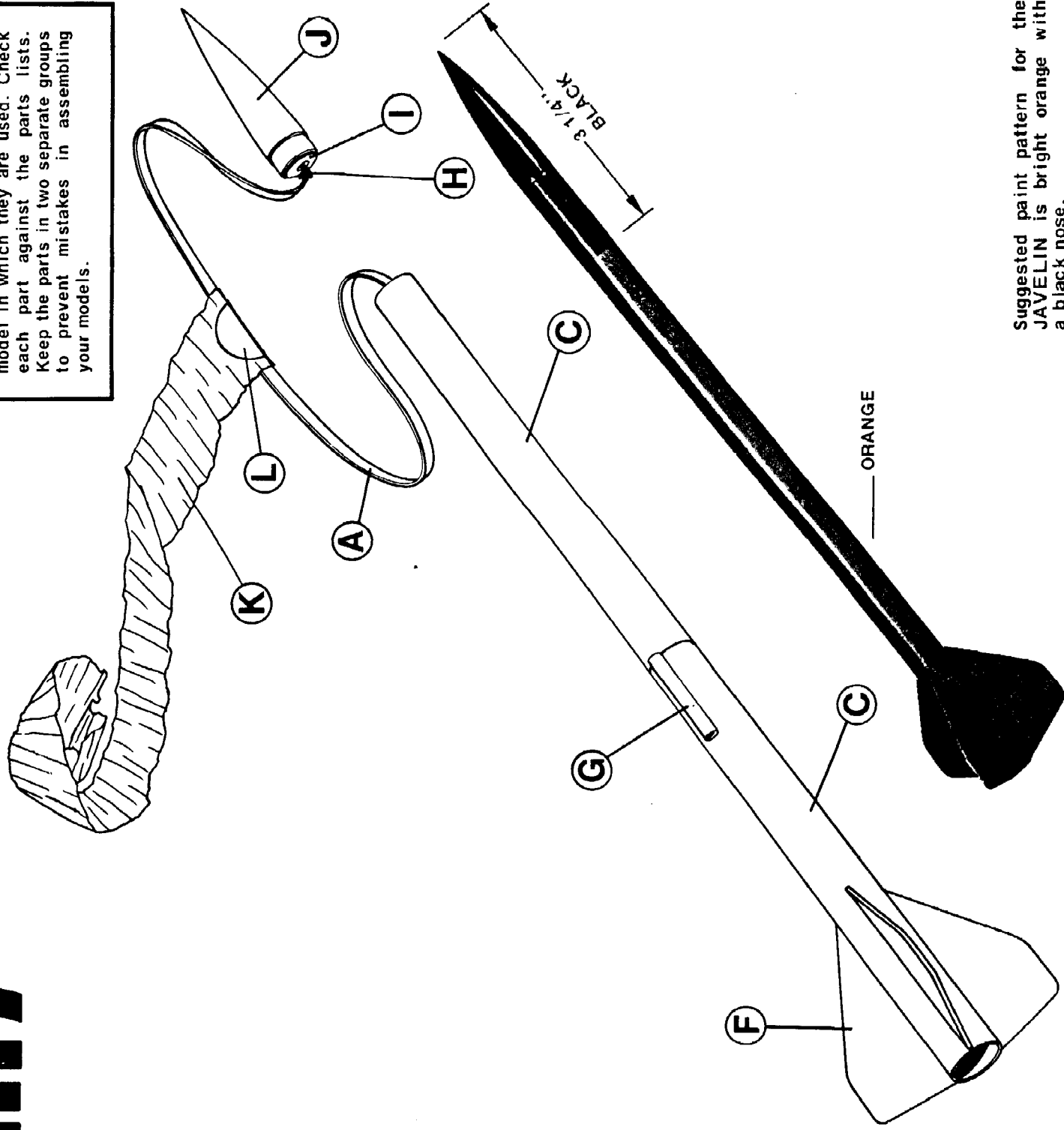

Suggested paint pattern for the JAVELIN is bright orange with a black nose.

ASSEMBLY INSTRUCTIONS (JAVELIN)

- 1 Tie one end of shock cord to the stage coupler.
- 2 Stretching the shock cord, glue half of the stage coupler into one end of one body tube. Let glue set, then pass shock cord through the tube and glue other body tube to the coupler. The ends of the body sections must fit evenly for a straight joint.
- 3 Mark the dummy engine casing 1/4" from one end. Smear glue around the inside of the body about 1-1/4" from the end. Insert the engine block and push forward with the casing until mark is even with end of the tube. Pull the casing out immediately.
- 4 Cut out the body marking guide. Wrap it around the body at the engine block end. Mark the tube at each arrow point. Remove guide and draw straight lines between the marks. Extend the launch lug line forward to the tube joint.
- 5 Cut out fin pattern. Trace on fin stock as shown. Cut out fins with a sharp hobby knife and sand edges as illustrated.
- 6 Rub a priming coat of glue into root edge of each fin. Glue fins next to alignment lines. Adjust fins so they stick straight away from the body, and let glue set. After glue is completely dry, apply a glue fillet to both sides of each fin.
- 7 Glue the launch lug to the body on the launch lug line so the front of the lug is at the tube joint. Make sure the lug is perfectly straight on the body.
- 8 Insert screw eye into base of nose cone. Remove screw eye and place nose weight on its shaft. Squirt glue into hole and replace screw eye.
- 9 Tie free end of the shock cord to screw eye. Attach streamer to shock cord with the tape disc about 3" from the nose cone.
- 10 To finish, apply one or more coats of sanding sealer to all balsa surfaces (after the glue is dry). Sand the model smooth after each coat of sealer dries. Paint after last coat dries.

1 TIE SHOCK CORD TO COUPLER



2 STRETCH THE SHOCK CORD, GLUE HALF COUPLER INTO TUBE

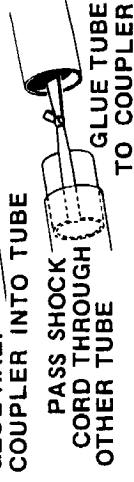

3 GLUE INSIDE BODY TUBE ← 1/4"

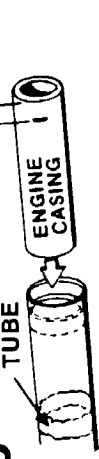

4 MARK TUBE AT EACH ARROW POINT



5 TRACE OUTLINES ON FIN STOCK



6 GLUE FILLET

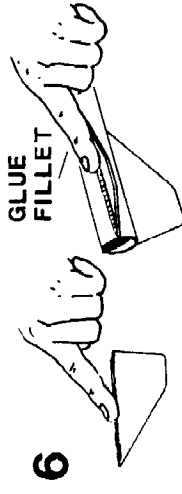

7 GLUE LAUNCH LUG AT THE TUBE JOINT



8 SQUIRT GLUE INTO HOLE



ADD WEIGHT AND REPLACE SCREW EYE

9 ATTACH THE STREAMER ABOUT 3" FROM THE NOSE CONE



COUNTDOWN CHECKLIST

- 14 Pack one square of crumpled recovery wadding loosely into the body tube.
- 13 Fold streamer in half two or three times, then roll it up so it fits easily in tube. Pack shock cord and streamer into tube.
- 12 Slide nose cone into place. Nose cone should separate easily from rocket body tube. If fit is too tight, sand inside of body tube end and shoulder of nose cone.
If nose cone is too loose, add a wrapping of masking tape to the shoulder of the nose cone.
- 11 Select an engine. Engines recommended for this rocket are 1/4A3-2T, 1/2A3-2T, and A3-4T. Use a 1/4A3-2T for first flight. Install igniter as directed in the engine instructions.
- 10 Wrap rear of engine with masking tape until it fits tightly in body tube. Engine must be tight for proper streamer ejection. Insert engine so it projects 1/4" from body.
- 9 Disarm the launch panel - remove safety key.
- 8 Place rocket on launch pad making sure it slides freely on rod. Clean micro-clips, and attach to the igniter.
- 7 Clear the launch area, alert recovery crew and trackers. Check for low flying aircraft and unauthorized persons in the recovery area.
- 6 Arm the launch panel - insert safety key.

MISFIRE PROCEDURE

Occasionally the igniter will heat and burn in two without igniting the engine. This is almost always caused by a failure to install it correctly. Disarm the launch panel, remove the model, clean the igniter residue from the nozzle, and install a new igniter. Follow the launching procedure again.

PACK ONE SQUARE OF RECOVERY WADDING INTO BODY TUBE

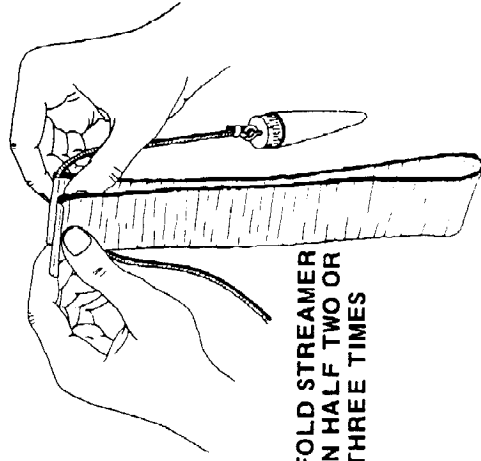

FOLD STREAMER IN HALF TWO OR THREE TIMES

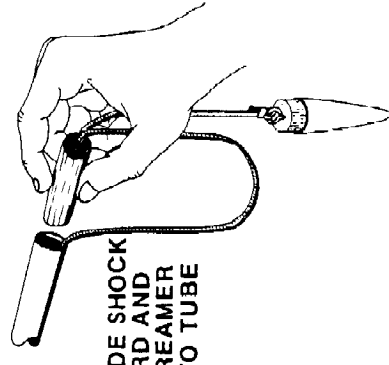

SLIDE SHOCK CORD AND STREAMER INTO TUBE

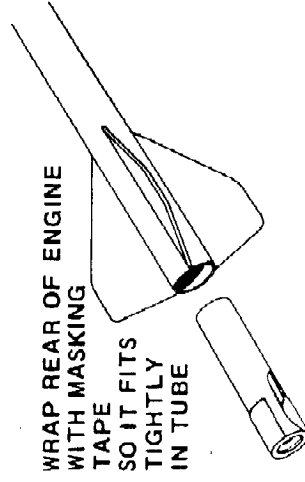

WRAP REAR OF ENGINE WITH MASKING TAPE SO IT FITS TIGHTLY IN TUBE

